

**INSTITUTE OF OCEANOGRAPHIC SCIENCES
DEACON LABORATORY**

INTERNAL DOCUMENT No. 329

Single card PC compatible computer

P K Smith

1994

Wormley
Godalming
Surrey GU8 5UB UK
Tel +44-(0)428 684141
Telex 858833 OCEANS G
Telefax +44-(0)428 683066

DOCUMENT DATA SHEET

AUTHOR SMITH, P K	PUBLICATION DATE 1994
TITLE Single card PC compatible computer.	
REFERENCE Institute of Oceanographic Sciences Deacon Laboratory, Internal Document, No. 329, 35pp. (Unpublished manuscript)	
ABSTRACT <p>This report details the construction and assembly of a single Eurocard PC (AT) compatible computer. The card has a 80386SX processor, maths co-processor, floppy disk controller, IDE standard hard disk controller, two serial ports and a printer port. It is manufactured by DSP Design.</p> <p>The advantage of this design is that any type of interface can be designed and fitted to the computer. This report includes an interface for the Sonic Anemometer and the Magnavox MX4200 GPS navigation system.</p> <p>Included are all the drawings for the panels and the wiring diagrams.</p>	
KEYWORDS	
ISSUING ORGANISATION <p>Institute of Oceanographic Sciences Deacon Laboratory Wormley, Godalming Surrey GU8 5UB. UK.</p> <p>Director: Colin Summerhayes DSc</p> <p>Telephone Wormley (0428) 684141 Telex 858833 OCEANS G. Facsimile (0428) 683066</p>	
Copies of this report are available from: The Library, PRICE £0.00	

SINGLE CARD PC COMPATIBLE COMPUTER

1.	ABSTRACT	7
2.	CONSTRUCTION AND ASSEMBLY OF COMPUTER	7
2.1.	Case	7
2.2.	Internal Divider	8
2.3.	Hinges	9
2.4.	LCD Display	10
2.5.	Hard Disk Module	11
2.6.	CPU Module	11
2.7.	Floppy disk Module	12
2.8.	Power Supply	12
2.9.	Parallel Printer Port	13
2.10.	Rear Panel	14
2.11.	Keyboard	15
3.	CONSTRUCTION AND ASSEMBLY OF INTERFACES	16
3.1.	Sonic interface rear panel	16
3.2.	GPS Interface rear panel	18

SINGLE CARD PC COMPATIBLE COMPUTER

1. ABSTRACT

This report details the construction and assembly of a single Eurocard PC (AT) compatible computer. The card has a 80386SX processor, maths co-processor, floppy disk controller, IDE standard hard disk controller, two serial ports and a printer port. It is manufactured by DSP Design .

The advantage of this design is that any type of interface can be designed and fitted to the computer. This report includes an interface for the Sonic Anemometer and the Magnavox MX4200 GPS navigation system

Included is all the drawings for the panels and the wiring diagrams.

2. CONSTRUCTION AND ASSEMBLY OF COMPUTER

2.1. Case

The case is a Vero type KM7 II 6U x 84 HP

Unpack case and ensure all parts are there

Item.	Description	Quantity
a.	Right hand panel	1
b.	Left hand panel	1
c.	Hex head M4 x 25 mm self tapping screws	8
d.	Central bar	1
e.	Top panel	1
f.	Bottom panel	1
g.	Plastic covers	2
a.	Tapped strips	2

Insert the tapped strips as a mirror image of the front tapped strips in the rear of both top and bottom panels from the left hand side (that is the low numbered end. The last 5 mm will require some force to insert.)

Select left hand panel and bottom panel (this has ventilation holes, where as the top panel has not)

Using the self tapping screws secure the parts together. Do not tighten the screws yet. Make sure the low numbers are on the left (note if the screws are stiff remove, clean thread and blow out swarf from the hole, then replace screw.)

Repeat with the top panel again ensure the low numbers are to the left.

Place case on it's side. Insert the plastic covers in the slots in the top panel.

Ensure the central bar fits in the two holes towards the rear in both the right and left hand panels. If they are a tight fit then insert one spigot at a time with a twisting motion. If it is still to tight the hole may be cleaned out with a suitable drill.

Screw on the right panel. ensuring the central bar has the single row of tapped holes facing forward.

Tighten all screws.

2.2. Internal Divider

The internal divider divides the case into one 6U x 60 HP section and an upper and lower 3U x 24 HP sections on the right hand side.

Ensure all parts are there

Item	Description	Quantity
a.	End plate with two lugs	1
b.	Horizontal bars	2
c.	Plastic end caps	2
d.	Tapped strips	2
e.	c/s screw M 2.5 x 4 mm	2
f.	c/s screw M 4 x 12 mm	6
g.	Plastic guides	2
h.	Vertical T support	1
i.	c/h Phillips screw M 2.5 x 5 mm	1
j.	Threaded stand-offs from the Display interface	2
k.	M 3 x 6 mm screw	2
l.	1 M ohm Potentiometer 10 turn pre-set	1
m.	c/h screw M 2 x 12 mm	2
n.	M 2 spring washers	2
o.	M 2 plain washers	8
p.	M 2 nuts	4
q.	Stand-off solder terminal (miniature)	2

Drill holes in the Vertical T support as diagram 1

Push the tapped strips into the horizontal bars with the tapped hole furthest from end in the lowest number position and the flat side to the rear

Position the two horizontal bars (with the low numbers to the left) and insert the two lugs of the metal end plate in each bar to the right hand side. Screw in 2 c/s screws M 4 x 12 mm towards rear of horizontal bars

The Plastic end caps are marked L and R. As the divider is to the right of the case select the end cap with R marked on it . The end cap with L on is not used in this configuration.

Position plastic end cap on the horizontal bars to the left hand side(wide part to front). Screw in 2 c/s screws M 4 x 12 mm towards front of horizontal bars.

Screw the metal plate to the inside of the case to the right and as far forward as it will go using 2 c/s screws M 2.5 x 4 mm.

Position and secure the stand-offs in the upper two holes with c/h M 3 x 6 mm screws

Secure the potentiometer with the M 2 screws then plain washer, nut, plain washer, potentiometer, spring washer, plain washer and nut.

Position and secure the solder tag stand-offs with M 2 plain washers and nuts.

Position the vertical T support with the small tag at the rear pointing left. Screw to horizontal bars through the plastic end cap using 2 c/s screws M 4 x 12 mm. and screw in the c/h Philips screw M2.5 x 5 mm. through the rear lug into the rear tapped strip.

2.3. Hinges

These are the Vero heavy duty metal type

Ensure all parts are there

Item	Description	Quantity
a.	Screen front panel as drawing 2.	1
b.	Outer case	2
c.	Inner holder	2
d.	Hinge piece	2
e.	c/s screw M 2.5 x 6 mm	4

Ensure the screen front panel fits into the case properly. The horizontal bars may need to be filed down if the panel touches at this place

Position the inner holder flat face down on the front of the screen front panel, over the rectangular cut-out at the top of the panel, the holes should line up.

Position the hinge piece so that the square lugs are behind the panel and the bevelled edge is towards the bottom.

Position the outer cover over the whole assembly with the bevelled edge to the bottom.

Screw in the 2 c/s M 2.5 x 6 mm screws from the rear of the panel.

Repeat the with the other hinge

To ensure the panel fits properly, fold the hinge piece out and position the square lugs into the slot that contains the tapped strip and screw into the upper tapped strip in positions 11 and 50 using c/h M 2.5 x 12 mm screws

The panel is secured at the bottom with c/h screws M 2.5 x 12 mm. that are only partly threaded.

2.4. LCD Display

The parts required

Item	Description	Quantity
a.	Screen front panel 6U x 60 HP with affixed acrylic screen as drawing 2 and 3	1
b.	LCD Display type Hitachi LMG 6123XUFC	1
c.	c/h M 3 screws x 20 mm	4
d.	M3 spring washers	4
e.	c/h M 3 x5 mm	2
f.	M3 plain washers	12
g.	M3 nuts	12
h.	10k potentiometer	1
i.	Black control knob	1

Remove front panel from case

The screen front panel requires the acrylic sheet to be secured with double sided sticky tape

Mount the display with 4 off M 3 screws x 20 mm using 8 mm length spacers and spring washers, plain washers and nuts.

If spacers are not available use 4 off M 3 x 20 mm screws held in place with spring washers, plain washers and nuts. Then put on nuts and plain washers then the display then spring washers, plain washers and nuts, so that the LCD screen is 0.5 mm off the acrylic screen.

Put a nut on the potentiometer, mount on front panel with crinkle washer and another nut.

Position and secure knob.

Mount the Display interface card on the Vertical T Piece using 2 off M 3 plain washers and nuts supplied with the stand-offs

Fold the hinge piece out and position the square lugs into the slot that contains the tapped strip and screw into the upper tapped strip in positions 11 and 50 using c/h M 2.5 x 12 mm screws

Connect up the ribbon cable from the forward upper connector to the display and the short power lead with the black wire to the bottom on the interface unit.

The panel is secured at the bottom with c/h screws M 2.5 x 12 mm. that are only partly threaded.

2.5. Hard Disk Module

The parts required.

Item	Description	Quantity
a.	Hard disk Type Seagate ST3096A	1
b.	Hard disk front panel 3U x 8 HP Drawing 4	1
c.	Hard disk side panel Drawing 5	1
d.	c/s M 2.5 x 6 mm Phillips screw	2
e.	c/h 4 BA x 1/4 inch screw	4
f.	Guide rails	2

The mounting threads on the Hard disk are 1/8 inch unc. If the correct screw is not available drill out the mounting holes with a 3 mm drill, and tap with a 4 BA tap. It is best to remove the side supports first so swarf will not damage the disk drive. Replace the side supports

Screw the side panel to the front panel using the c/s M 2.5 x 6 mm Phillips screws.

Screw the hard disk to the side panel using c/h 4 BA x 1/4 inch screws

Position the guide rails top and bottom in the upper section in position 67 with the tag to the left and insert the hard disk module.

2.6. CPU Module

The parts required

Item	Description	Quantity
a.	CPU card DSP Design EC386 with co-processor.	1
b.	Vero module 3U x 8 HP with the 220 mm horizontal bars	1
c.	Guide rails	2

Cut the horizontal bars down to 200 mm. File the ends smooth and square

Tap the holes in the horizontal bars with the M 2.5 tap

Secure the top bar with a c/s M 2.5 x 12 mm Phillips screw

Secure the bottom bar with a c/h M2.5 x 10 mm Phillips screw

Insert the CPU card in the guide rail with the push button switch to the bottom left

Position the die cast end piece on the end of the top guide rail with the lug pointing down and screw in place with c/h M 2.5 x 12 mm screw

Repeat with the other end piece on the bottom guide rail with the lug pointing up

Position the CPU card over the tapped holes in the end pieces and secure in place with c/h M 2.5 x 4 mm screws

Position the guide rails top and bottom in the upper section in position 70 with the lug to the right and insert the CPU module

2.7. Floppy disk Module

The parts required

Item	Description	Quantity
a.	Floppy disk drive type Mitsubishi MF355C-250M	1
b.	Floppy disk front panel 3U x 8 HP Drawing 6	1
c.	Floppy disk side panel Drawing 7	1
d.	c/s M 2.5 x 6 mm Phillips screw	2
e.	c/h M 3 x 10 mm screw	4
f.	Guide rails	2

Screw the side panel to the front panel with the c/s M 2.5 x 6 mm screws

Mount the Floppy disk on the side panel with c/h M 3 x 10 mm screws

Position the guide rails top and bottom in the upper section in position 83 with the tag to the left and insert the floppy disk module

2.8. Power Supply

The parts required

Item	Description	Quantity
a.	Power supply module 3U x 24 HP	1
b.	Power supply Type 89-1558B	1
c.	Guide rails	2

Fix top rail to front panel with the c/s screw and the bottom rail with the c/h screw.

Secure the end pieces to the top and bottom rails so that the lugs point towards each other and to the right when looking at the ends of the rails with the posidrive c/h screws

Slide the power supply in place and secure with the c/h screws passing through the connector.

Position the guide rails top and bottom in the lower section in position 66 with the tag to the left and insert the power supply module

2.9. Parallel Printer Port

The parts required

Item	Description	Quantity
a.	Parallel printer port front panel 3U x 10 HP Drawing 8	1
b.	Cable assembly as drawing 11	1
c.	Connector fixing kit	1

Position the 25 way D type connector on the back of the panel

Secure in place using the tapped head screw, spring washer, plain washer and nut.

2.10. Rear Panel

The parts required

Item	Description	Quantity
a.	IEC Mains connector	1
b.	IEC Mains boot	1
c.	Small fuse holder	1
d.	Cable assembly as drawing 11	1
e.	3 M x 10 mm c/s screws	3
f.	3 M spring washers	3
g.	3 M plain washers	3
i.	3 M nuts	3
j.	3 mm solder tag	1
k.	20 mm 1A anti-surge fuse	1
l.	Rubber sleeve 2 mm dia x 10 mm	2
m.	Power supply Connector	1
n.	Hard Disk power connector	1
o.	10 way ribbon cable with 10 way IDC connector	1
p.	PC Bus connector	1
q.	Rubber sleeving 2 mm x 20 mm	16
r.	Equipment wire 16 x 0.2	
s.	Rear panel 6U x 24 HP Drawing 9	1

Position the IEC mains connector in the cut-out with the earth pin upper most. Secure in place with c/s M 3 x 10 mm screws then spring washers, plain washers and nuts

Position the fuse holder with the location lug upper most and secure in place with nut.

Position a c/s M 3 x 10 mm screw in the hole beneath the connector, put the solder tag on and secure in place with a spring washer, plain washer and nut

Solder wire to the IEC mains connector as in Drawing 10

Twist the wires together for a short length

Position the IEC boot over the IEC mains connector

Continue wiring as Drawing 10 covering the exposed wiring with rubber sleeving x 10 mm for the fuse holder and 20 mm sleeving for all other connections and twisting together the wires.

Unsolder the DIN socket on the Breakout panel making a note of the connections.

Remove the DIN connector and position the DIN socket with lug to the top and secure in place with the nut.

Re-solder the cable assembly to the DIN socket as before

Wire up the potentiometers on the display and T piece as diagram 10

Connect all other cables as diagram 11

2.11. Keyboard

The keyboard is mounted separately

The parts required

a.	Compact keyboard type G800-1800 HAG /07	1
b.	Shelve and slides for Compact keyboard	1

The keyboard slots into the shelve and connects into the 5 pin DIN socket on the rear panel

3. CONSTRUCTION AND ASSEMBLY OF INTERFACES FOR SONIC AND GPS

3.1. Sonic interface rear panel

The parts required

Item	Description	Quantity
a.	Rear panel 6U x 60 HP drawing No. 12	1
b.	Internal panel as drawing No. 13	1
c.	Sonic Power supply and interface unit	1
d.	IEC mains plug	1
e.	IEC mains boot	1
f.	Miniature Panel fuse holder	1
g.	IEC mains socket	1
h.	9 way female connector	1
i.	15 way female connector	1
j.	9 way male connector	1
k.	15 way male connector	1
l.	c/h M 4 screw x 12 mm	4
m.	M 4 spring washer	4
n.	M 4 plain washer	4
o.	M 4 nut	4
p.	Solder tag	1
q.	c/s M 3 screw x 10 mm	2
r.	M 3 spring washer	2
s.	M 3 plain washer	2
t.	M 3 nut	2
u.	Fixing kit for connectors	1
v.	9 way cover	1
w.	15 way cover	1
x.	Rubber sleeving	
y.	Cable ties	
z.	Equipment wire 16 x 0.2	

Position the IEC mains connector in the cut-out with the earth pin upper most. Secure in place with c/s M 3 x 10 mm screws then spring washers, plain washers and nuts

Position the fuse holder with the location lug upper most and secure in place with nut.

Solder a length of brown wire to the Live terminal, Blue wire to the Neutral terminal and 2 lengths of Green/Yellow wire to the earth terminal

Twist the wires together for a short length

Position the IEC boot over the IEC mains connector

Cut one of the earth wires so that it will reach the 4 mm hole for use by the interface mounting board and solder a 4 mm solder tag to it.

Unscrew the screws in the lid of the box place the interface mounting plate over the lid and replace the screws. If they are not long enough replace with longer screws.

Screw the mounting board to the rear panel with c/h M 4 screw x 12 mm screws then plain washers then the interface mounting panel so that the Sonic interface box Mains connector is near the fuse holder, next the solder tag then the spring washers, plain washers and nuts

Cut the brown wire to reach the fuse holder

Solder wire to the rear contact on the fuse holder covering with rubber sleeving x 10 mm.,

Solder a length of brown wire to the other contact on the fuse holder and cover with rubber sleeving x 10 mm.

Twist the wires together and cut to suitable length for the mains socket

Pass the wires into the IEC free socket and solder brown to live, blue to neutral and green/yellow to earth then tighten the cable clamp. Plug into the Sonic interface box.

Secure the 15 way and the 9 way D type in place with the fixing kits

Solder 15 blue wires to the 15 way female connector and cover with rubber sleeving x 10 mm. Repeat with 9 red wires to the 9 way female connector.

Cut the wires to the correct length to reach the connectors on the Sonic interface box

Solder to the 15 and 9 way male connectors to corresponding pins covering with rubber sleeving x 10 mm.

Fix the 15 way and the 9 way covers over the connector and plug in to the Sonic interface box.

Secure the female connector to the rear panel using the mounting kits

Tidy the wires and secure with some cables ties

Secure the rear panel using M 2.5 partially threaded screws.

3.2. GPS Interface rear panel

Item	Description	Quantity
a.	Rear panel 6U x 60 HP drawing No. 14	1
b.	Internal panel as drawing No. 15	1
c.	Power supply type RS 591 310	1
d.	IOS Interface unit	1
e.	IEC mains plug	1
f.	IEC mains boot	1
g.	Miniature Panel fuse holder	1
h.	6 way Cannon connector	1
i.	25 way male D type connector	1
j.	Fixing kit for connector	1
k.	c/h M 4 screw x 12 mm	4
l.	M 4 spring washer	4
m.	M 4 plain washer	8
n.	M 4 nut	4
o.	Solder tag	1
p.	c/s M 3 screw x 10 mm	6
q.	c/s M 3 screw x 6 mm	8
r.	M 3 spring washers	10
s.	M 3 plain washer	10
t.	M 3 nut	10
u.	Insulated stand-offs	4
v.	9 way D type female	2
w.	9 way D type covers	2
x.	Rubber grommet 3/8 "	1
y.	Rubber sleeving	
z.	Equipment wire 16 x 0.2	

Position the IEC mains connector in the cut-out with the earth pin upper most. Secure in place with c/s M3 x 10 mm screws then spring washers and plain washers and nuts

Position the fuse holder with the location lug upper most and secure in place with nut.

Solder a length of brown wire to the Live terminal, Blue wire to the Neutral terminal and 2 lengths of Green/Yellow wire to the earth terminal

Twist the wires together for a short length

Position the IEC boot over the IEC mains connector

Cut one of the earth wires so that it will reach the 4 mm hole for use by the interface mounting board and solder a 4 mm solder tag to it.

Position the Power supply on the mounting board and secure in place with c/s 3 M x 10 mm screws.

Screw the stand-offs in place with 3 M x 6 mm c/s screws

Position the interface card on the stand-offs and secure with 3 M spring washers, plain washers and nuts

Screw the mounting board to the rear panel with c/h M 4 screws x 12 mm screws then plain washers then the interface mounting panel, next the solder tag then the spring washers, plain washers and nuts

Cut the brown wire to reach the fuse holder

Solder wire to the rear contact on the fuse holder covering with rubber sleeving x 10 mm.,

Solder a length of brown wire to the other contact on the fuse holder and cover with rubber sleeving x 10 mm.

Twist the wires together and cut to suitable length to reach the power supply

Connect the Brown wire to Live on the Power supply with another Brown wire to the Live on the interface card

Connect the Blue wire to Neutral on the Power supply with another Blue wire to the Neutral on the interface card

Connect the Green/Yellow wire to Earth on the Power supply

Position the 25 way D type and secure in place with the fixing kit.

Position the Cannon 6 way connector and secure in place with c/h 3 M x 6 mm screws spring washers and nuts.

Place a grommet in the hole above the fuse holder and pass the GPS power lead through it.

Connect a wire to the +12V and 2 wires to the 0V and the GPS power lead on the power supply. Solder the +12V wire to pin F and one of the 0V wires to pin B on the Cannon connector and cover with 10 mm rubber sleeving. The other 0V wire connect to the Earth on the interface board.

Solder a wire to pin C, cover with 10 mm rubber sleeving and cut to length to reach the breakout Panel and solder to pin 5 on a 9 way D Type, cover with 10 mm rubber sleeving.

Solder a wire to pin E, cover with 10 mm rubber sleeving and cut to length to reach the breakout Panel and solder to pin 2 on the 9 way D Type, cover with 10 mm rubber sleeving.

Fix a 9 way cover over the 9 way D type connector

Connect one wire in each position on the 6 way terminal block on the interface card and connect up as below.

Cover each with 10 mm rubber sleeving.

Wire	Pin	Connector
1	3	25 way D type
2	15	25 way D type
3	2	9 way D type
4	3	9 way D type
5	2	25 way D type
6	14	25 way D type

Connect a wire to Earth on the interface board and solder to pin 5 on 9 way D type. Ensure the wires are long enough to reach the breakout panel

Fix a 9 way cover over the 9 way D type connector

Secure the rear panel using M 2.5 partially threaded screws.

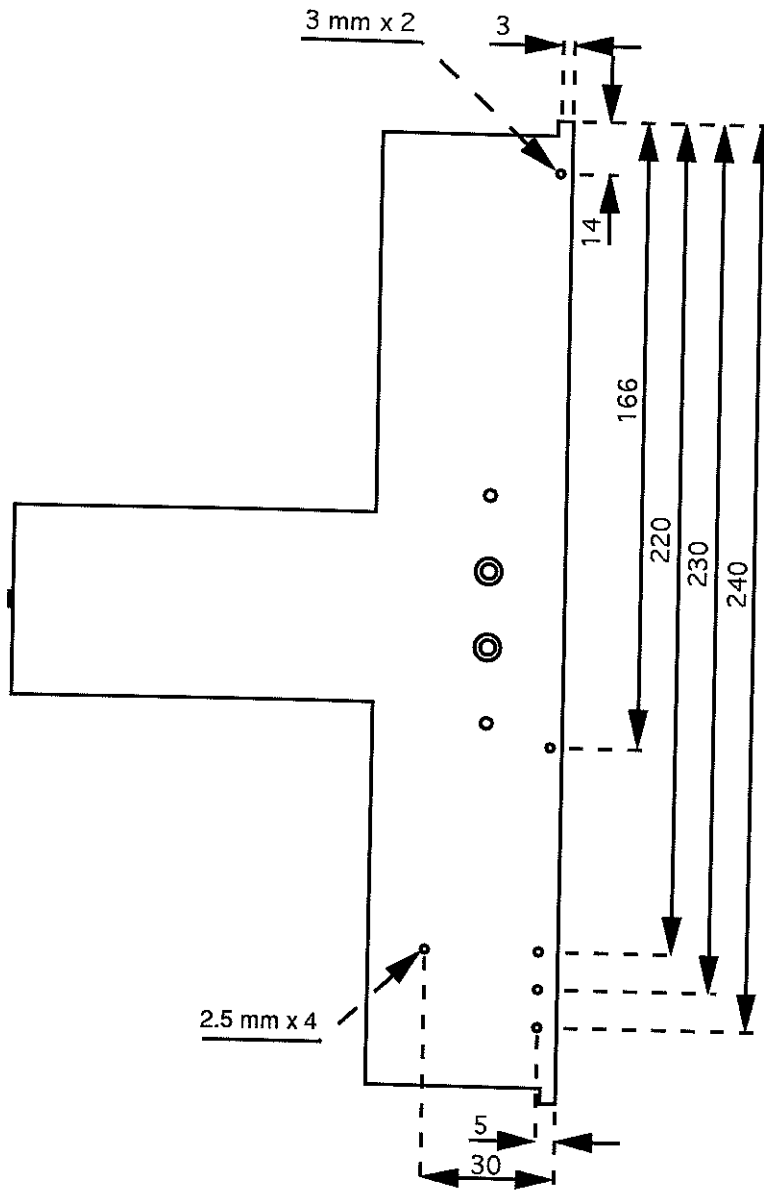

DRAWING NUMBER DSP 1

MAT:- AS SUPPLIED	TITLE:- T - PIECE
SCALE:- 2:1	DRN:- PKS
TOL:- 0.1 mm	DATE:- 27/07/92

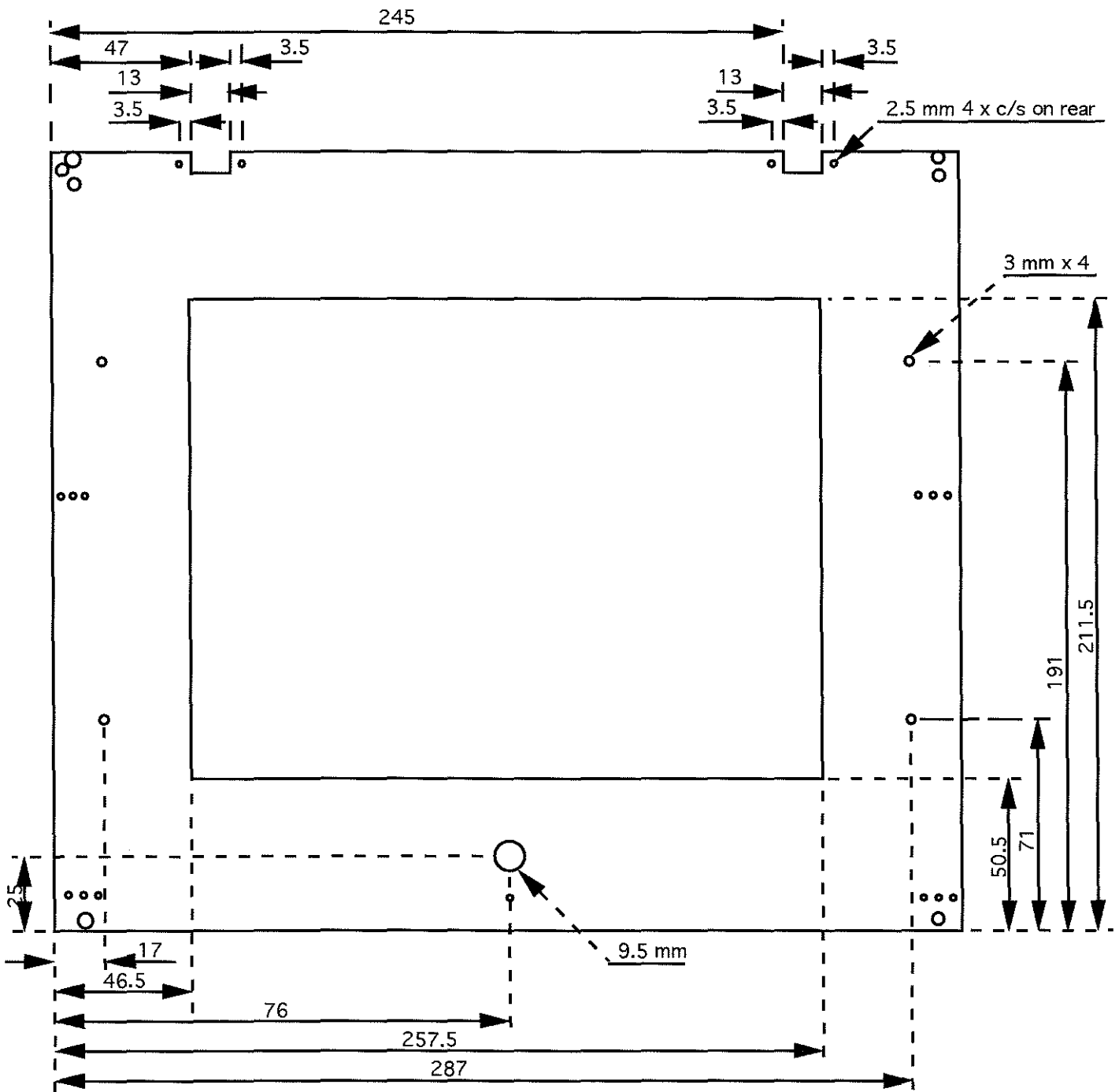

DRAWING NUMBER DSP 2

MAT:- AS SUPPLIED	TITLE:- L.C.D. FRONT PANEL
SCALE:- 2:1	DRN:- PKS
TOL:- 0.1 mm	DATE:- 18/11/92

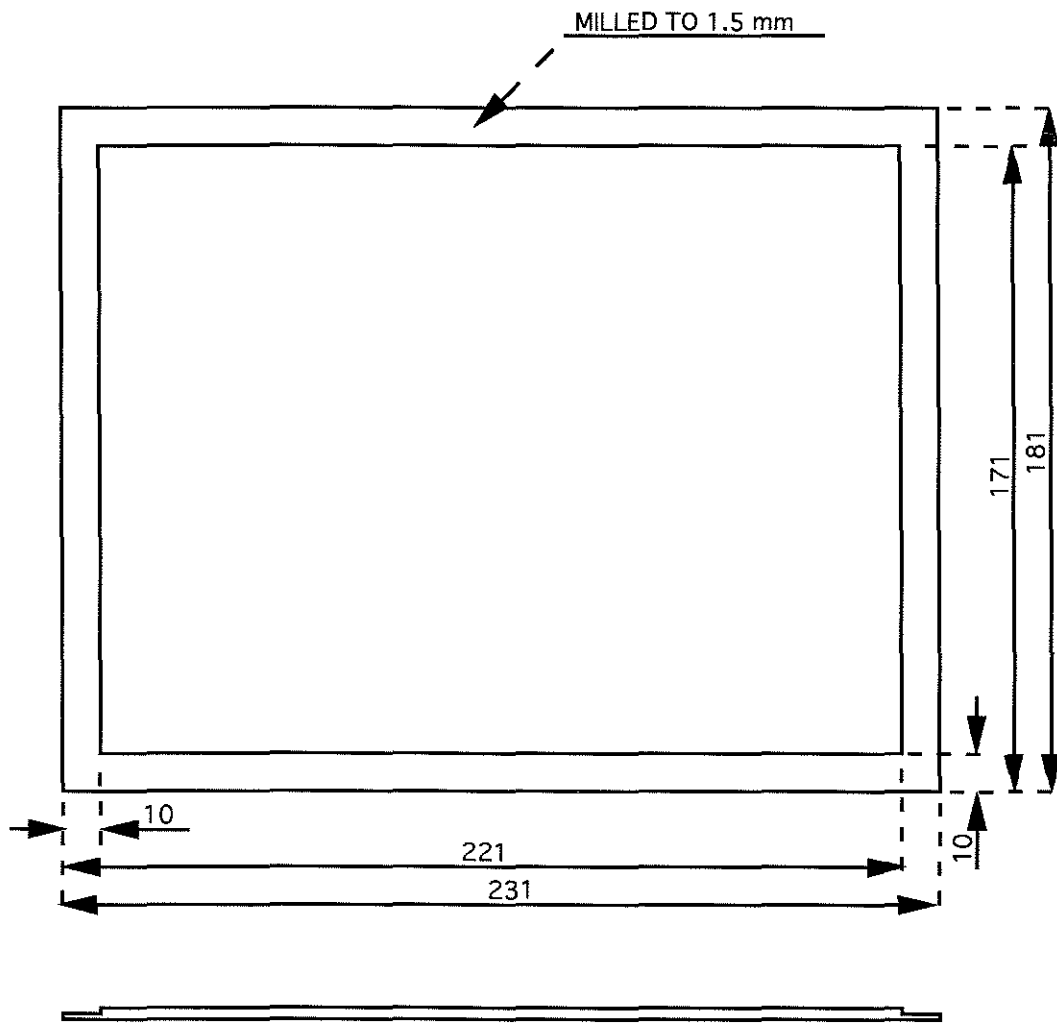

DRAWING NUMBER DSP 3

MAT:- 3 mm ACRILC SHEET	TITLE:- ACRILIC SCREEN
SCALE:- 2:1	DRN:- PKS
TOL:- 0.1 mm	DATE:- 23/11/92

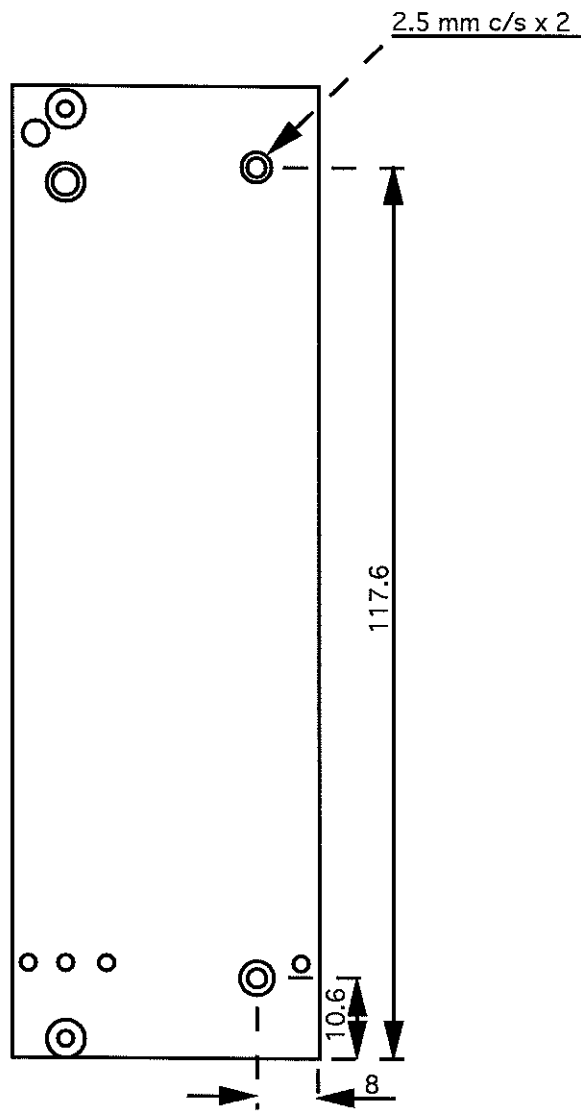

DRAWING NUMBER DSP 4

MAT :- AS SUPPLIED	TITLE :- HARD DISK FRONT PANEL
SCALE :- 1:1	DRN :- PKS
TOL :- 0.1 mm	DATE :- 08/12/92

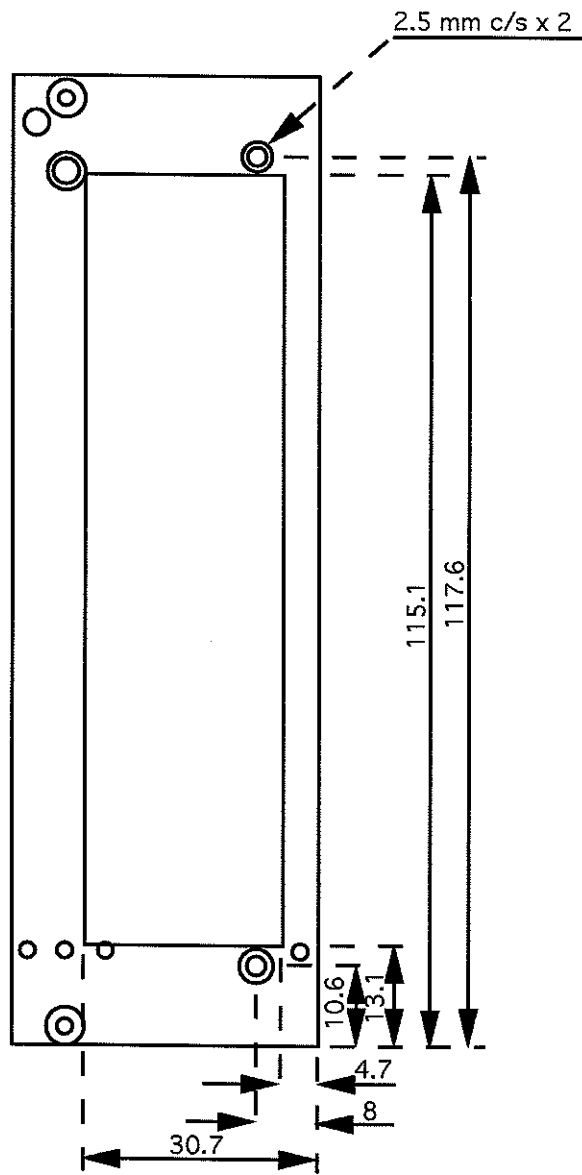

DRAWING NUMBER DSP 6

MAT :- AS SUPPLIED	TITLE :- FLOPPY DISK FRONT PANEL
SCALE :- 1:1	DRN :- PKS
TOL :- 0.1 mm	DATE :- 23/11/92

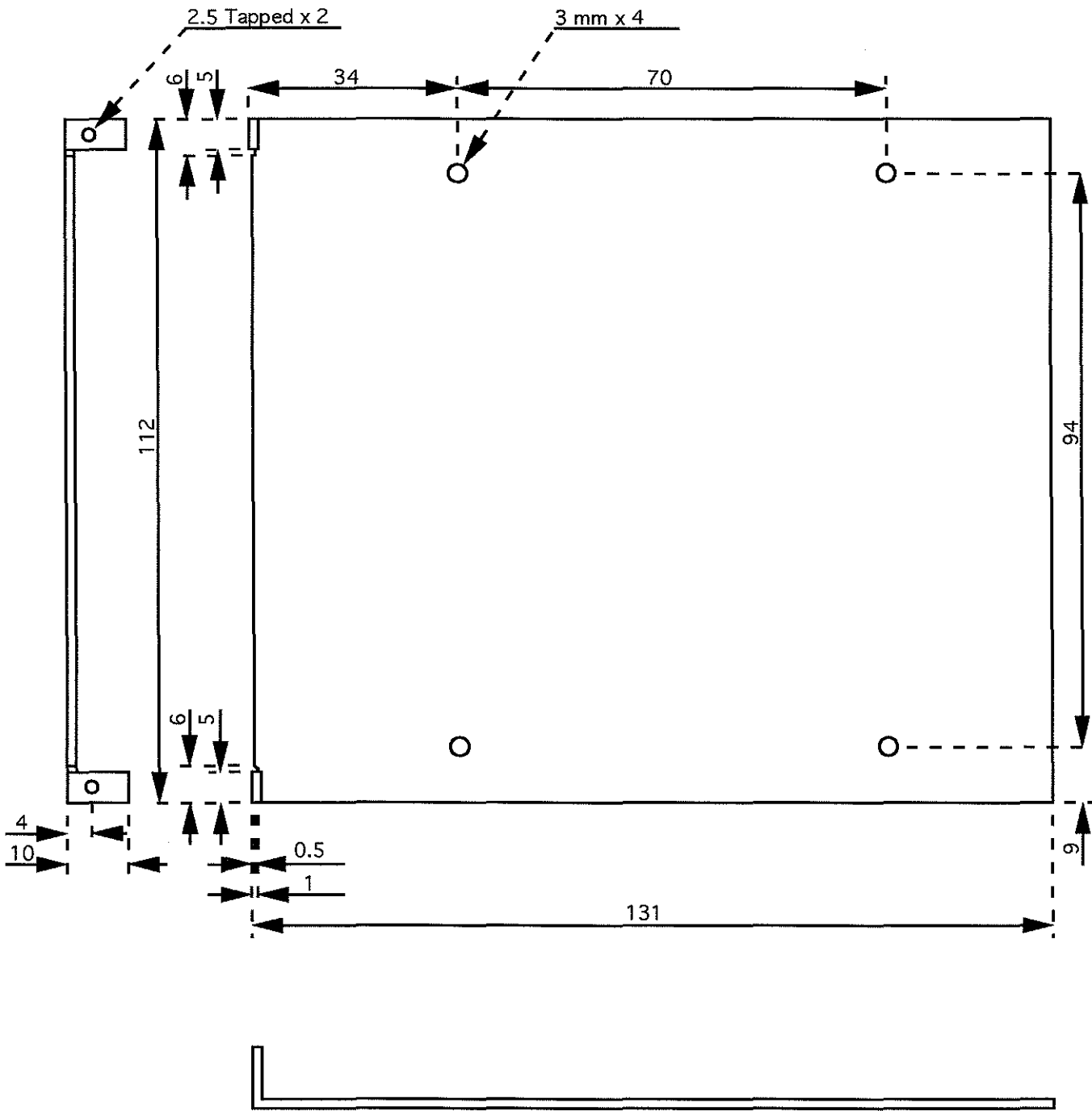

DRAWING NUMBER DSP 7

MAT:- 1.6 mm AL. SHEET
SCALE:- 1:1
TOL:- 0.1 mm

TITLE:- FLOPPY DISK SIDE PANEL
DRN:- PKS
DATE:- 23/11/92

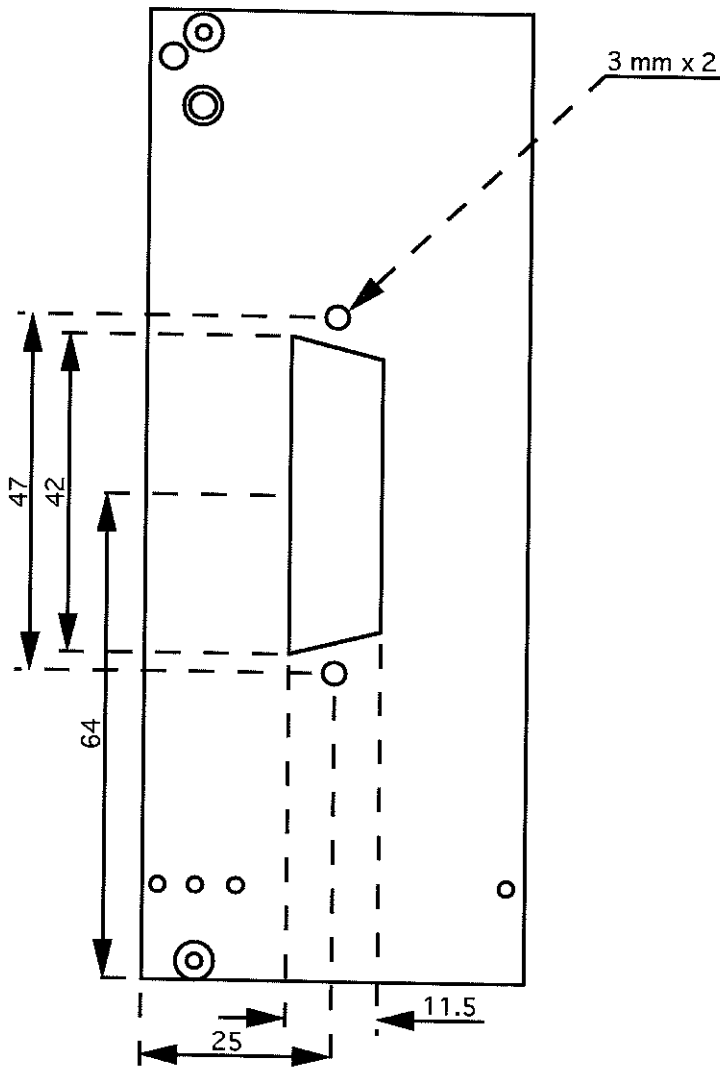

DRAWING NUMBER DSP 8

MAT :- AS SUPPLIED	TITLE :- I.O. PORT FRONT PANEL
SCALE :- 1:1	DRN :- PKS
TOL :- 0.1 mm	DATE :- 09/12/92

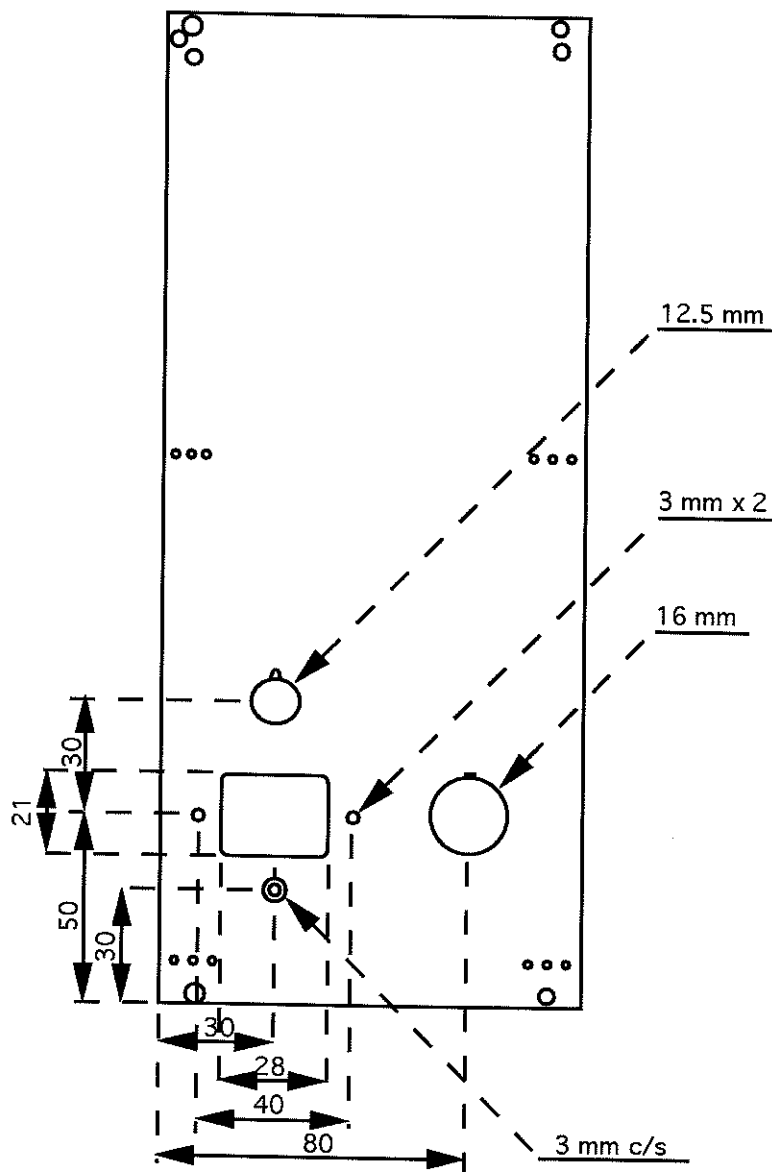

DRAWING NUMBER DSP 9

MAT:- AS SUPPLIED	TITLE:- COMPUTER REAR PANEL
SCALE:- 2:1	DRN:- PKS
TOL:- 0.1 mm	DATE:- 23/11/92

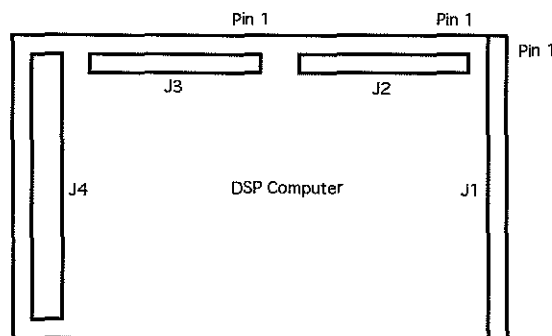
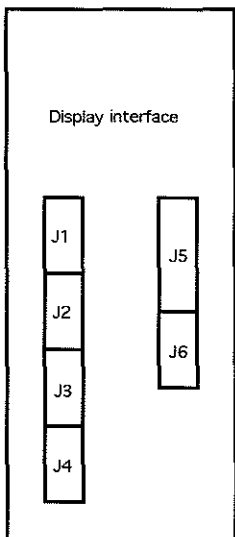
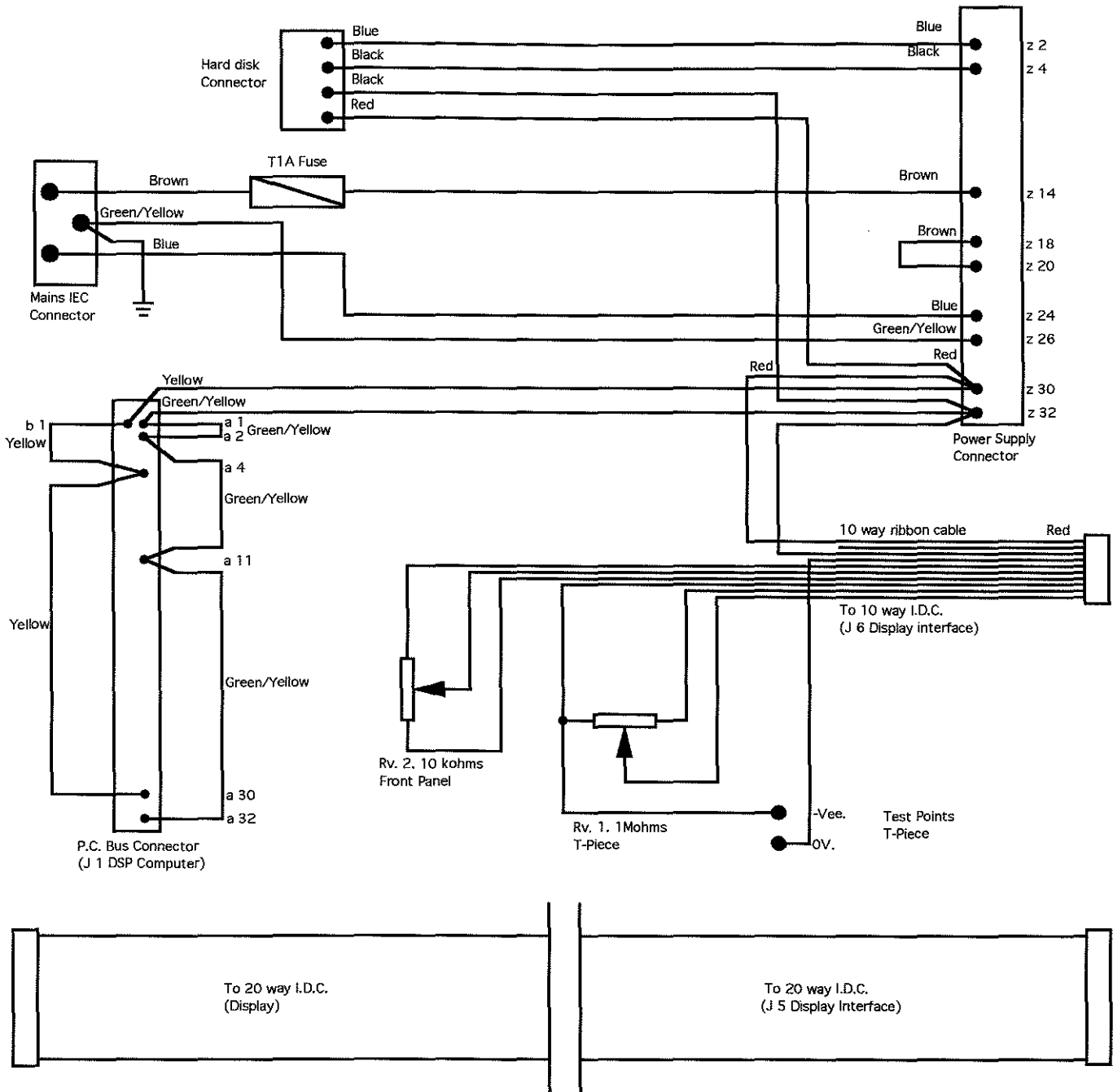

DRAWING NUMBER DSP 10

MAT:-
SCALE:
TOL:-

TITLE:- INTERNAL WIRING
DRN:- PKS
DATE:- 06/10/93

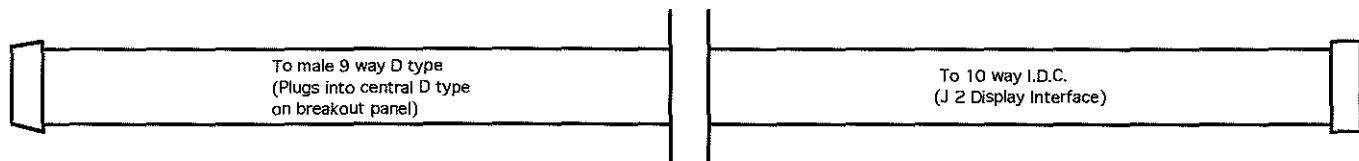
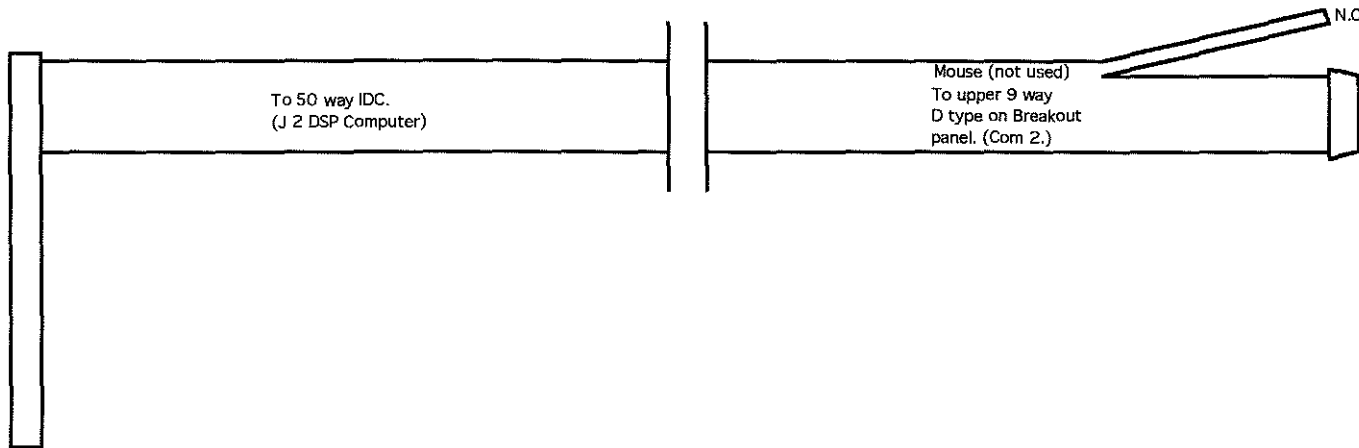
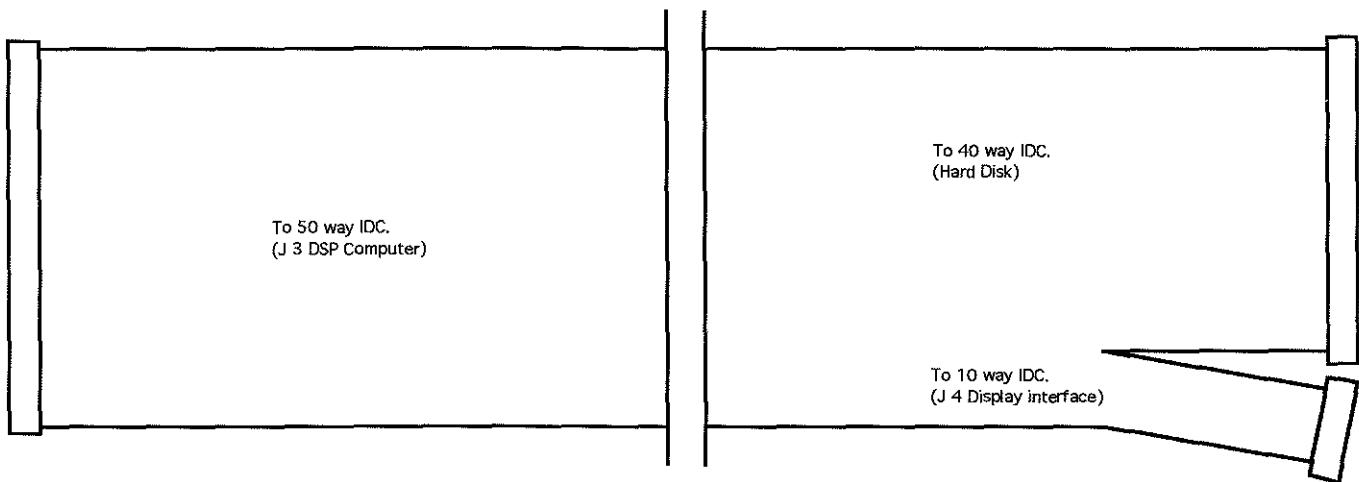
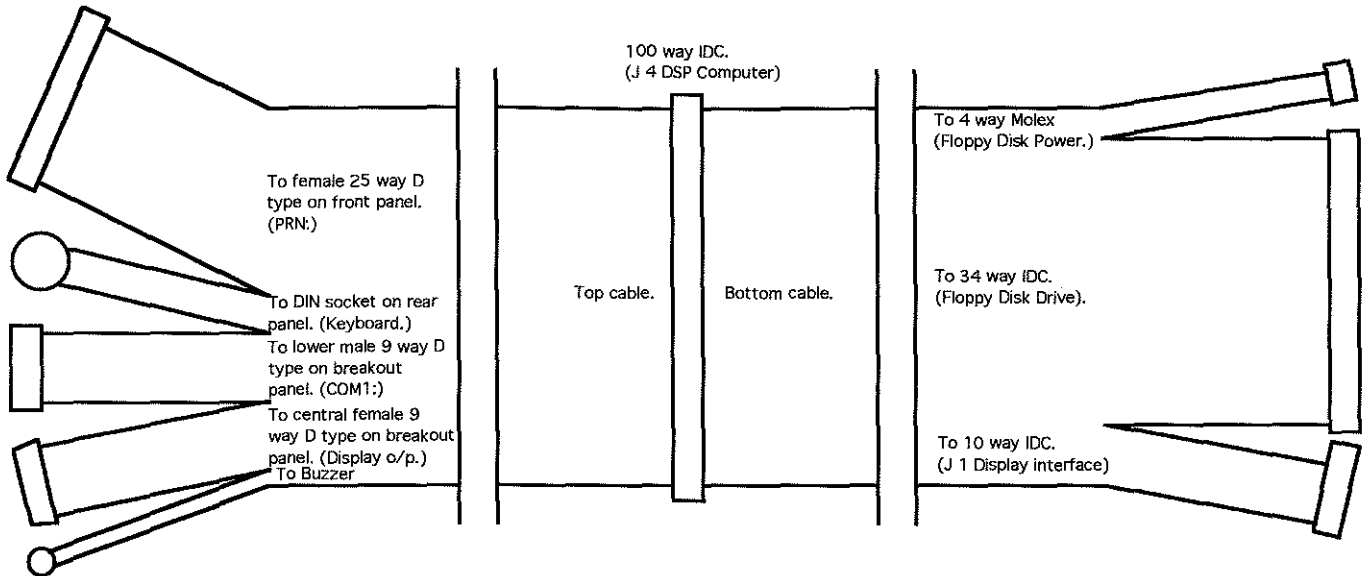

DRAWING NUMBER DSP 11

MAT:- AS SUPPLIED
 SCALE:-
 TOL:-

TITLE:- CABLES
 DRN:- PKS
 DATE:- 06/10/93

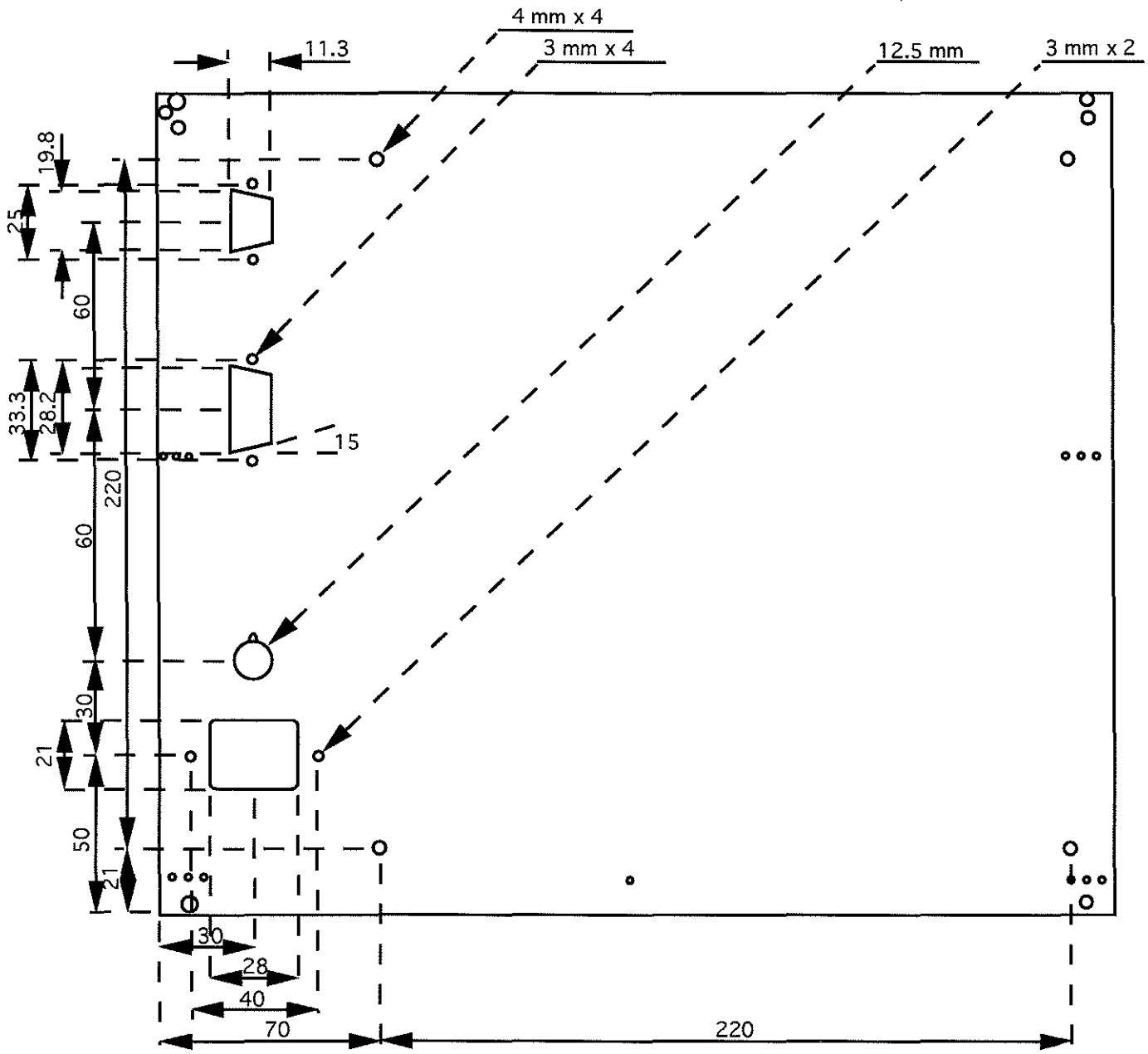

DRAWING NUMBER DSP 12

MAT:- AS SUPPLIED
SCALE:- 2:1
TOL:- 0.1 mm

TITLE:- SONIC REAR PANEL
DRN:- PKS
DATE:- 28/07/93

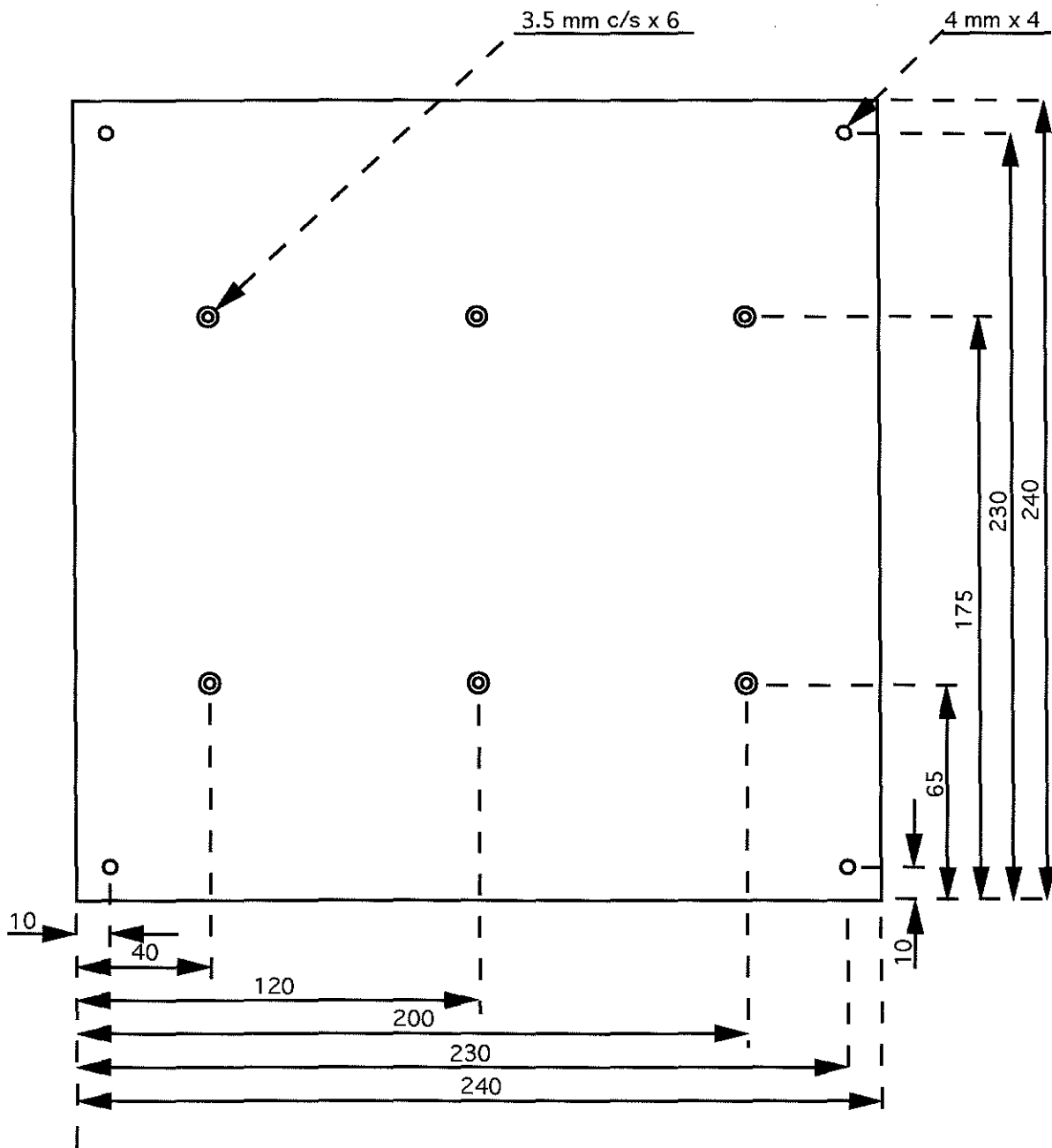

DRAWING NUMBER DSP 13

MAT:- ALUMINIUM SHEET 1.6 mm
SCALE:- 2:1
TOL:- 0.1 mm

TITLE:- SONIC INTERFACE BOARD
DRN:- PKS
DATE:- 28/07/93

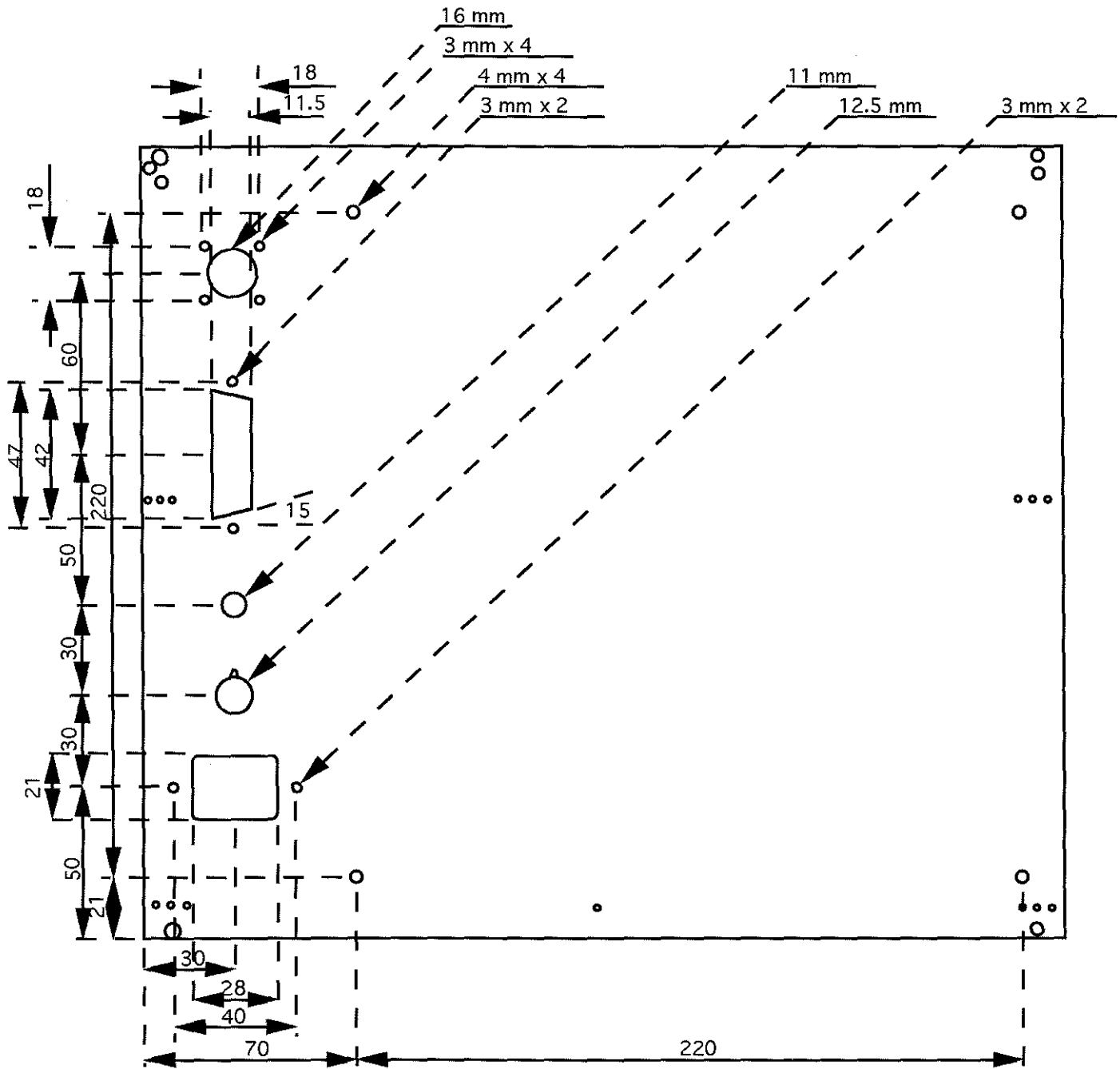

DRAWING NUMBER DSP 14

MAT:- AS SUPPLIED	TITLE:- G.P.S. REAR PANEL
SCALE:- 2:1	DRN:- PKS
TOL:- 0.1 mm	DATE:- 23/11/92

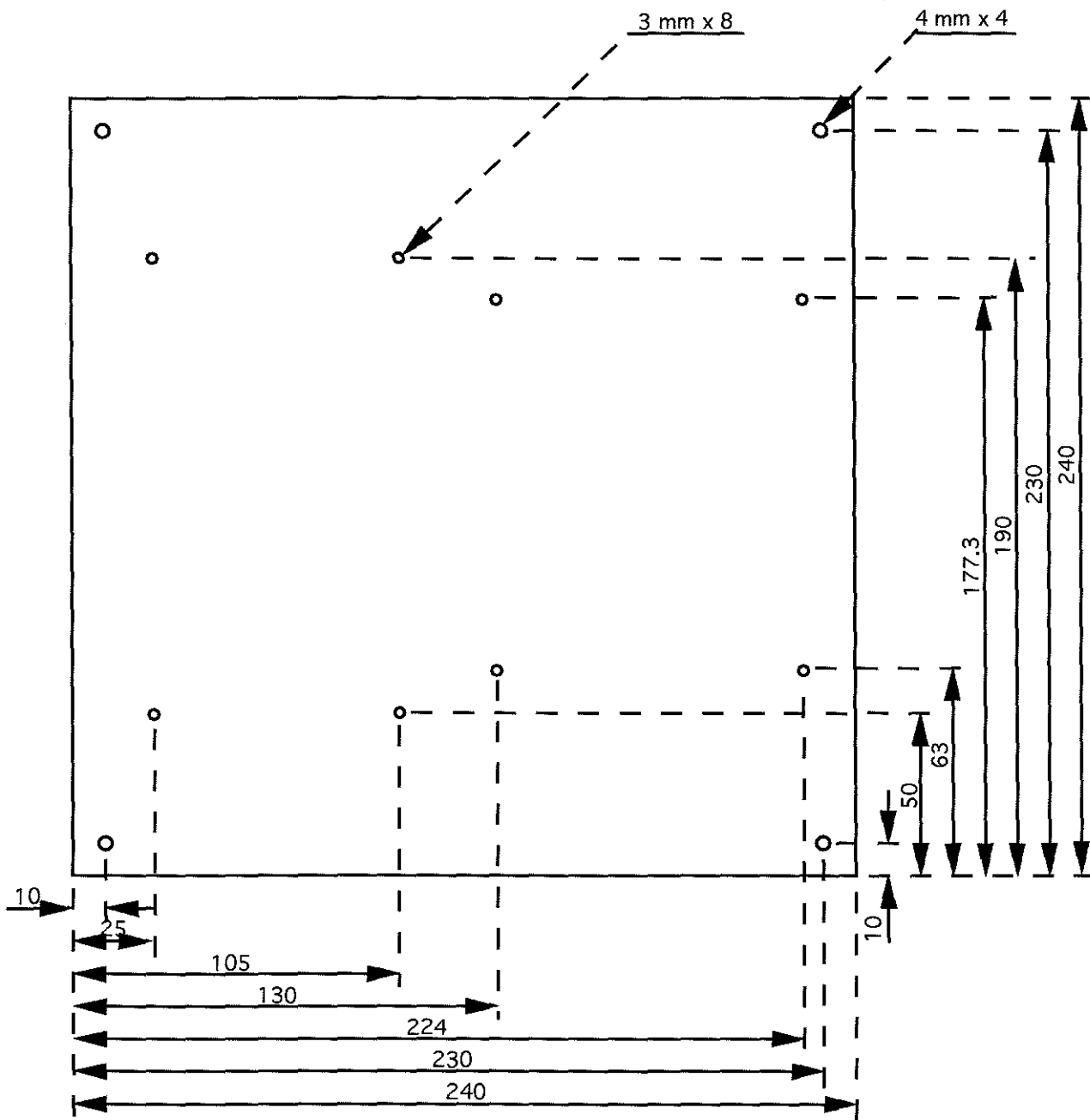

NOTE :- ALL 3 mm HOLES
C/S ON REVERSE SIDE

DRAWING NUMBER DSP 15

MAT:- ALUMINIUM SHEET 1.6 mm	TITLE:- GPS INTERFACE BOARD
SCALE:- 2:1	DRN:- PKS
TOL:- 0.1 mm	DATE:- 19/11/92