

Opening Opportunities for High-Resolution Isotope Analysis - Quantification of $\delta^{15}\text{N}_{\text{NO}_3}$ and $\delta^{18}\text{O}_{\text{NO}_3}$ in Diffusive Equilibrium in Thin-Film Passive Samplers

Sophie A. Comer-Warner,^{*,†,‡,ⓧ} Stefan Krause,[†] Daren C. Gooddy,[‡] Sarah A. Bennett,^{§,#} Sarah K. Wexler,^{||} and Jan Kaiser^{||,ⓧ}

[†]School of Geography, Earth and Environmental Sciences, University of Birmingham, Edgbaston, Birmingham B15 2TT, U.K.

[‡]British Geological Survey, Maclean Building, Wallingford, Oxfordshire OX10 8BB, U.K.

[§]NERC Isotope Geoscience Laboratory, British Geological Survey, Keyworth, Nottingham NG12 5GG, U.K.

^{||}Centre for Ocean and Atmospheric Sciences, School of Environmental Sciences, University of East Anglia, Norwich Research Park, Norwich NR4 7TJ, U.K.

Supporting Information

ABSTRACT: The fate of nitrate transported across groundwater-surface water interfaces has been intensively studied in recent decades. The interfaces between aquifers and rivers or lakes have been identified as biogeochemical hotspots with steep redox gradients. However, a detailed understanding of the spatial heterogeneity and potential temporal variability of these hotspots, and the consequences for nitrogen processing, is still hindered by a paucity of adequate measurement techniques. A novel methodology is presented here, using Diffusive Equilibrium in Thin-film (DET) gels as high-spatial-resolution passive-samplers of $\delta^{15}\text{N}_{\text{NO}_3}$ and $\delta^{18}\text{O}_{\text{NO}_3}$ to investigate nitrogen cycling. Fractionation of $\delta^{15}\text{N}_{\text{NO}_3}$ and $\delta^{18}\text{O}_{\text{NO}_3}$ during diffusion of nitrate through the DET gel was determined using varying equilibrium times and nitrate concentrations. This demonstrated that nitrate isotopes of $\delta^{15}\text{N}_{\text{NO}_3}$ and $\delta^{18}\text{O}_{\text{NO}_3}$ do not fractionate when sampled with a DET gel. $\delta^{15}\text{N}_{\text{NO}_3}$ values from the DET gels ranged between 2.3 ± 0.2 and $2.7 \pm 0.3\text{‰}$ for a NO_3^- stock solution value of $2.7 \pm 0.4\text{‰}$, and $\delta^{18}\text{O}_{\text{NO}_3}$ values ranged between 18.3 ± 1.0 and $21.5 \pm 0.8\text{‰}$ for a NO_3^- stock solution of $19.7 \pm 0.9\text{‰}$. Nitrate recovery and isotope values were independent of equilibrium time and nitrate concentration. Additionally, an *in situ* study showed that nitrate concentration and isotopes provide unique, high-resolution data that enable improved understanding of nitrogen cycling in freshwater sediments.

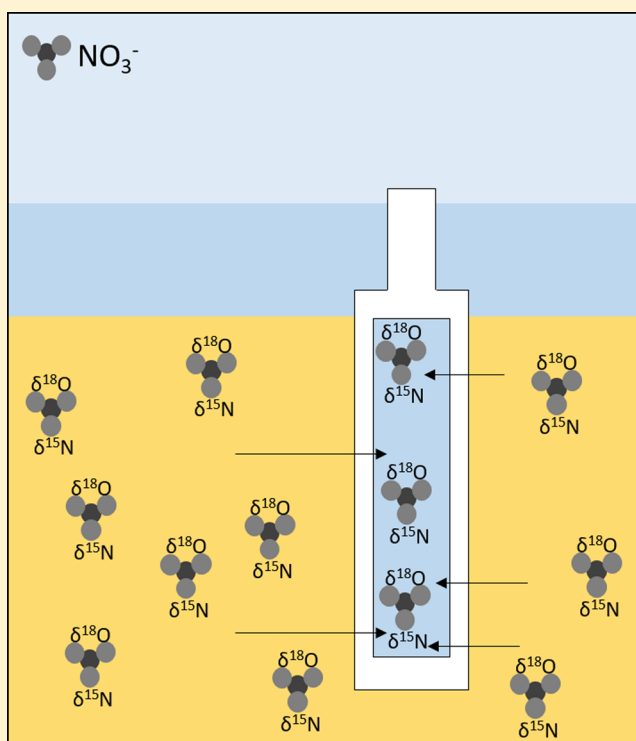

The transport and transformation of nitrate across groundwater-surface water interfaces has been intensively studied over the past few decades, resulting in the identification of hotspots of increased biogeochemical turnover in these areas.^{1–4} However, our understanding of the spatial patterns and temporal dynamics of nitrogen processing at the sediment interfaces between aquifers and rivers or lakes is still hampered by a critical lack of adequate monitoring methodologies.^{5–9} In particular, there is a vital need for *in situ* data providing a more detailed insight into gradients of nutrient cycling at small spatial scales.⁵ Isotopic data is particularly crucial as it is able to provide additional source and process information that concentration data alone cannot.^{10,11} Such information is

crucial for improving mechanistic process understanding of ecosystem functioning across spatial and temporal scales and to support integrated river and groundwater management and restoration so that freshwater systems are managed effectively.^{12–15}

A promising technological advancement has been the emergence of Diffusive Equilibrium in Thin-film (DET) gel samplers, to passively collect chemical constituents in water,

Received: January 3, 2017

Accepted: March 1, 2017

Published: March 1, 2017

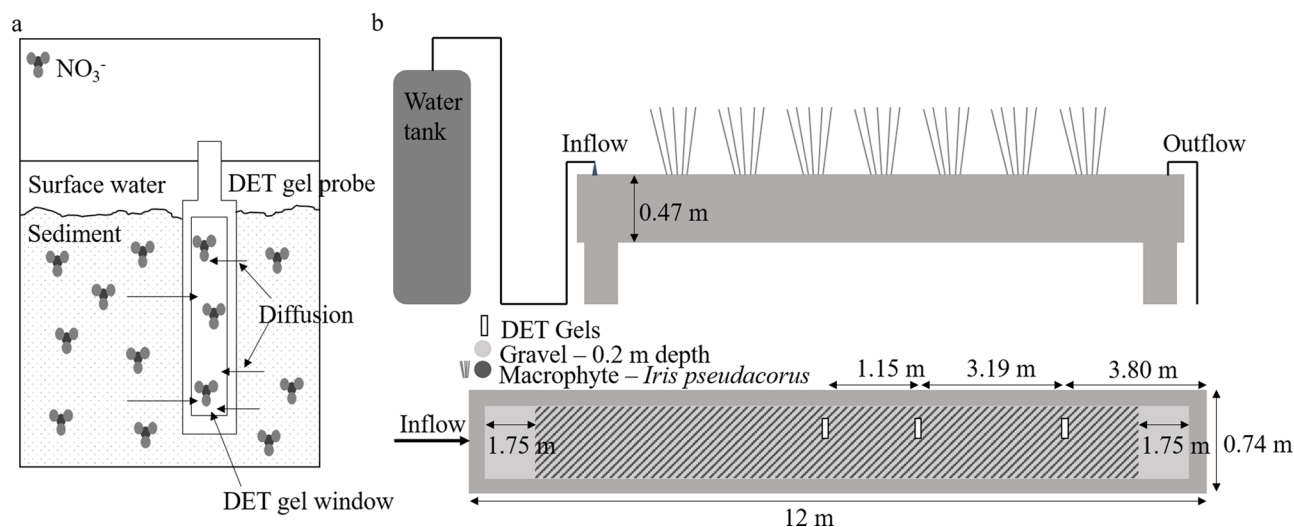

Figure 1. a. A depiction of the DET gel deployment, showing its position in the sediment and diffusion of nitrate molecules from the higher concentration sediment environment into the lower concentration DET gel. b. A schematic of the mesocosms at the Urban River Laboratory, Montornès del Vallès Wastewater Treatment Plant, Montornès del Vallès, Spain used for the *in situ* proof of concept. Shown are the positions of the DET gels within the vegetation of the flume.

soil, and sediment (Figure 1). Besides a wide range of contaminants, DET gels have been applied to analyze vertical profiles of nitrate concentrations at high spatial resolutions of 1 cm, providing significant advantages over traditional sampling methods, such as multilevel piezometers.^{14,16–19} Recently, this spatial resolution has been further improved to millimeter scale using colorimetry and hyperspectral imagery to obtain simultaneous nitrate/nitrite profiles.²⁰ The application of DET gels at groundwater-surface water interfaces supports the identification of discrete zones of concentrations of nitrate, nitrite, and ammonium, including the characterization of differing redox zones and hotspots of biogeochemical reactivity.¹⁴ DET gels have been used recently to investigate coupled nitrification-denitrification and dissimilatory nitrate reduction to ammonium; however, no evidence was provided demonstrating there was no fractionation on diffusion of nitrate through the DET gel, and only $\delta^{15}\text{N}_{\text{NO}_3}$ was considered.^{21,22}

Here we present a new method, which combines the advantages of high-resolution sampling by DET technology with the analysis of nitrate isotope ratios to quantify nitrogen cycling at groundwater-surface water interfaces. Recognizing the limitations of inferring biogeochemical cycling and nutrient dynamics from concentration data alone, we propose the use of DET gels as a high resolution, *in situ* sampler, of nitrate isotopes in addition to concentration data. The measurement of $\delta^{15}\text{N}_{\text{NO}_3}$ and $\delta^{18}\text{O}_{\text{NO}_3}$ provides useful information on the processes controlling nitrate concentrations in hotspots of biogeochemical turnover in areas such as aquifer-lake or aquifer-river interfaces.¹⁰ Additionally, the sources of nitrate measured may be identified, as nitrate from differing sources often has distinct isotopic values of $\delta^{15}\text{N}_{\text{NO}_3}$ and $\delta^{18}\text{O}_{\text{NO}_3}$, enabling identification of nitrate sources affecting freshwater systems.¹⁰ This combination of high-resolution sampling and process inference from tracer analysis provides significant potential for increasing our understanding of hotspots of biogeochemical turnover and differing redox zones in the hyporheic zone, therefore, allowing more effective management of freshwater systems.

EXPERIMENTAL SECTION

Laboratory experiments were performed to determine the potential for fractionation of $\delta^{15}\text{N}_{\text{NO}_3}$ and $\delta^{18}\text{O}_{\text{NO}_3}$ during the diffusion of nitrate through DET gels. Thereby, during laboratory experiments, the influences of two key controls were investigated for their impacts on fractionation; (1) the concentration of nitrate in the initial solution and (2) the time allowed for diffusive equilibrium of the nitrate from the initial solution into the DET gel. An initial proof of concept study was conducted using an isotope technique requiring 1 mg NO_3^- -N resulting in the requirement of high nitrate concentrations (up to 7.0 g NO_3^- L⁻¹). Subsequently, a more environmentally relevant experiment was performed to verify the results, using an isotope technique requiring 0.7 μg NO_3^- -N, and therefore, much lower nitrate concentrations between 20.1 and 100.5 mg NO_3^- L⁻¹ could be used. A field trial was then conducted to demonstrate the additional insight gained through high spatial resolution $\delta^{15}\text{N}_{\text{NO}_3}$ and $\delta^{18}\text{O}_{\text{NO}_3}$ data; in addition to nitrate concentration data, this was also conducted using the isotope technique requiring 0.7 μg NO_3^- -N.

Laboratory Experiments. Proof of Concept Study. Equilibration of DET Gels in Nitrate Solutions. A 3 × 4 × 0.2 cm polyacrylamide DET gel (DGT Research Ltd.) was immersed in an unagitated 100 mL solution of known NO_3^- concentration, in an acid-washed (10% HCl) beaker. Solutions of 3.3 ± 0.0, 4.8 ± 0.0, and 7.0 ± 0.1 g NO_3^- L⁻¹ were used, with each concentration being equilibrated for three different time periods: 24, 48, and 168 h. A river sample spiked with nitrate (7.0 ± 0.0 g NO_3^- L⁻¹) was also used to test for matrix effects; the river sample was collected from the River Tern, U.K. and filtered (0.2 μm). All experiments were performed in triplicate, and the concentration of the stock solution was compared to that of the solution in the beaker after the gel was removed. A concentration 97.7% that of the stock solution was expected due to the gel volume being 2.3% of the solution volume. The solution concentrations were found to be 95.0 ± 3.0% that of the stock (*n* = 12).

Back-Equilibration from DET Gels. At the end of the equilibration period DET gels were removed from solution and

weighed in a preweighed centrifuge tube to determine the weight of each gel. The solution volume of each gel was calculated from the weight multiplied by the assumed water content of the saturated gel (95%). Twenty-five ml of ultrapure water was added to each gel, and the gels were shaken on a reciprocating shaker for 24 h, after which the gels were removed and the back-equilibrated samples were frozen for chemical analysis. Nitrate concentrations were determined using ion chromatography (Dionex ICS1100); standards were used as quality controls and gave an accuracy of 0.4 mg L^{-1} , precision of $\pm 0.4 \text{ mg L}^{-1}$, and a limit of detection of 0.5 mg L^{-1} .

Laboratory Experiment at Environmentally Relevant Concentrations. The proof of concept experiment outlined above was repeated to investigate isotope fractionation at environmentally relevant nitrate concentrations, using an equilibration time of 24 h. Solutions of 20.1 ± 0.0 , 50.8 ± 0.2 , and $100.5 \pm 0.3 \text{ mg NO}_3^- \text{ L}^{-1}$ were used, as well as a filtered ($0.2 \mu\text{m}$) river sample (Wood Brook, Mill Haft, U.K.) with a concentration of $23.1 \pm 0.0 \text{ mg NO}_3^- \text{ L}^{-1}$. During back-equilibration 20 mL of ultrapure water was added to each gel, and nitrate concentrations were determined on a Continuous Flow Analyzer (Skalar Sans++). Standards were used as quality controls and gave an accuracy of $0.4 \text{ mg NO}_3^- \text{ L}^{-1}$, precision of $\pm 0.1 \text{ mg NO}_3^- \text{ L}^{-1}$, and a limit of detection of $0.9 \text{ mg NO}_3^- \text{ L}^{-1}$. The concentration of the stock solution was compared to that of the solution in the beaker after the gel was removed. A concentration 97.7% that of the stock solution was expected due to the gel volume being 2.3% of the solution volume, and solution concentrations were found to be $96.8 \pm 1.1\%$ that of the stock ($n = 4$).

In Situ Field Trial. Field Trial Study Site. For a field trial, proving the concept of DET isotope analysis in sediments, gel probes were deployed at the Urban River Laboratory (URL) located at the Montornès del Vallès Wastewater Treatment Plant, Montornès del Vallès, Spain. The mesocosm flumes are 12 m long, 0.74 m wide, and 0.47 m deep (Figure 1), with wastewater treatment effluent flowing into the channel. The flumes are filled to 20 cm depth with gravel and planted with *Iris pseudacorus*. Flow conditions were subsurface during installation of the DET gels; after 49 h a flood event was simulated, creating 8 cm surface flow, which lasted for the remaining 16 h of the gel deployment.

DET Probe Deployment in Sediments. Three $0.16 \times 15 \times 1$ cm DET gels (DGT Research) were deployed for 65 h in the vegetated zone of the flume (Figure 1). The deployment period exceeded estimated exposure times required to ensure concentration equilibrium by diffusion in order to account for resettling of any potential sediment disturbances during the probe deployment. Gel 1 was deployed closest to the inflow: 3.86 m from the beginning of the flume. Gel 2 was deployed 1.15 m downstream of gel 1, and gel 3 was deployed 3.19 m downstream of gel 2 and 3.80 m from the end of the flume (Figure 1).

All gels were extracted from the sediment within 10 min and immediately sliced at 2.5 cm intervals within 40 min. The DET gels were sliced (ultrapure water-rinsed blade) on an acid-washed (10% HCl) chopping board. Once sliced, the gels were placed into 50 mL centrifuge tubes and stored at $4 \text{ }^\circ\text{C}$.

Nitrate Elution from DET Gel Probes. The DET gels were back-equilibrated, on ice, with 6 mL of ultrapure water on a reciprocating shaker for 24 h. Once equilibrated the gels were removed and weighed, the eluate was then filtered ($0.2 \mu\text{m}$),

and the eluate was frozen for later analysis. Samples were analyzed for nitrate concentration on a continuous flow analyzer (Skalar San++); standards were used as quality controls and gave an accuracy of $0.1 \text{ mg NO}_3^- \text{ L}^{-1}$, precision of $\pm 0.1 \text{ mg NO}_3^- \text{ L}^{-1}$, and a limit of detection of $0.9 \text{ mg NO}_3^- \text{ L}^{-1}$.

Isotope Analysis. For the laboratory proof of concept experiments the nitrate was extracted from the samples using anion and cation exchange columns and converted to silver nitrate using the method in Chang²³ and Heaton²⁴ or a modified version of this as subsequently described. For river samples with the presence of interfering anions, the method by Chang²³ and Heaton²⁴ was used; for the pure NO_3^- solutions, the samples were not passed through anion and cation exchange columns. Instead the nitrate was converted to silver nitrate, and the above method was used from the point of adding the first batch of Ag_2O . The silver nitrate was analyzed by mass spectrometry as in Heaton.²⁴ The international isotope reference materials used for $\delta^{15}\text{N}$ were IAEA-N-1 and IAEA-N-2, with $\delta^{15}\text{N}$ values vs air of +0.4 and +20.4‰, respectively, with a measurement precision of ± 0.3 and $\pm 0.5\%$, respectively. The international isotope reference materials used for $\delta^{18}\text{O}$ were IAEA- NO_3 , USGS-34, and USGS-35, with $\delta^{18}\text{O}$ vs SMOW of +26.0, -28.0, and +56.4‰, respectively, with a measurement precision of ± 1.2 , ± 1.7 , and $\pm 1.9\%$, respectively. Analysis was performed at the NERC Isotope Geoscience Laboratory, British Geological Survey.

For the laboratory experiment at environmentally relevant concentrations and the field study data, the denitrifier method was used as this requires a lower mass of nitrate for analysis ($0.7 \mu\text{g NO}_3^- \text{ N}$).^{25,26} This method utilizes denitrifying bacteria to convert sample nitrate to N_2O , with a long-term measurement precision of ± 0.3 and $\pm 0.4\%$ and an accuracy of 0.0 and 0.0‰ for $\delta^{15}\text{N}_{\text{NO}_3}$ and $\delta^{18}\text{O}_{\text{NO}_3}$, respectively, and a measurement limit of $2 \mu\text{M NO}_3^-$. The international isotope reference materials used were IAEA- NO_3 , USGS-34, and USGS-35, with $\delta^{15}\text{N}$ of +4.7, -1.4, and +3.4‰, respectively, with a measurement precision of ± 0.3 , ± 0.6 , and $\pm 0.5\%$, respectively, and $\delta^{18}\text{O}$ of +25.7, -28.0, and +57.4‰, respectively, with a measurement precision of ± 0.7 , ± 0.6 , and $\pm 0.6\%$, respectively. Analysis was performed by the Analytical Facilities, University of East Anglia.

RESULTS AND DISCUSSION

Laboratory Experiments. Nitrate Concentrations from DET Gels. Nitrate concentrations were recovered from the DET gels with ranges between 3.6 ± 0.1 and 3.7 ± 0.1 for a $3.3 \pm 0.0 \text{ g NO}_3^- \text{ L}^{-1}$ stock solution, between 5.2 ± 0.3 and 5.3 ± 0.1 for a $4.8 \pm 0.0 \text{ g NO}_3^- \text{ L}^{-1}$ stock solution, between 6.7 ± 0.1 and 6.9 ± 0.0 for a $7.0 \pm 0.1 \text{ g NO}_3^- \text{ L}^{-1}$ stock solution, and 6.3 ± 0.0 and 6.8 ± 0.1 for a $7.0 \pm 0.0 \text{ g NO}_3^- \text{ L}^{-1}$ spiked river sample (Table S-1). The nitrate concentration data showed that all of the experiments reached equilibrium with a nitrate recovery between 90.4 ± 0.3 and $112.1 \pm 4.0\%$, which was independent of equilibrium time with a fitted linear model having an adjusted R^2 value of -0.01 and p-value of 0.96 (Figure S-1). The concentration appears to have affected the recovery of nitrate with a fitted linear model having an adjusted R^2 value of 0.80 and p-value of 0.00 (Figure S-1). However, despite the large adjusted R^2 value, solution concentrations of 3.3 ± 0.0 and $4.8 \pm 0.0 \text{ g NO}_3^- \text{ L}^{-1}$ showed similar recoveries, even though one solution is only 70% of the concentration of the other, which is unexpected if there is a strong dependence of nitrate recovery on concentration. The observed recoveries

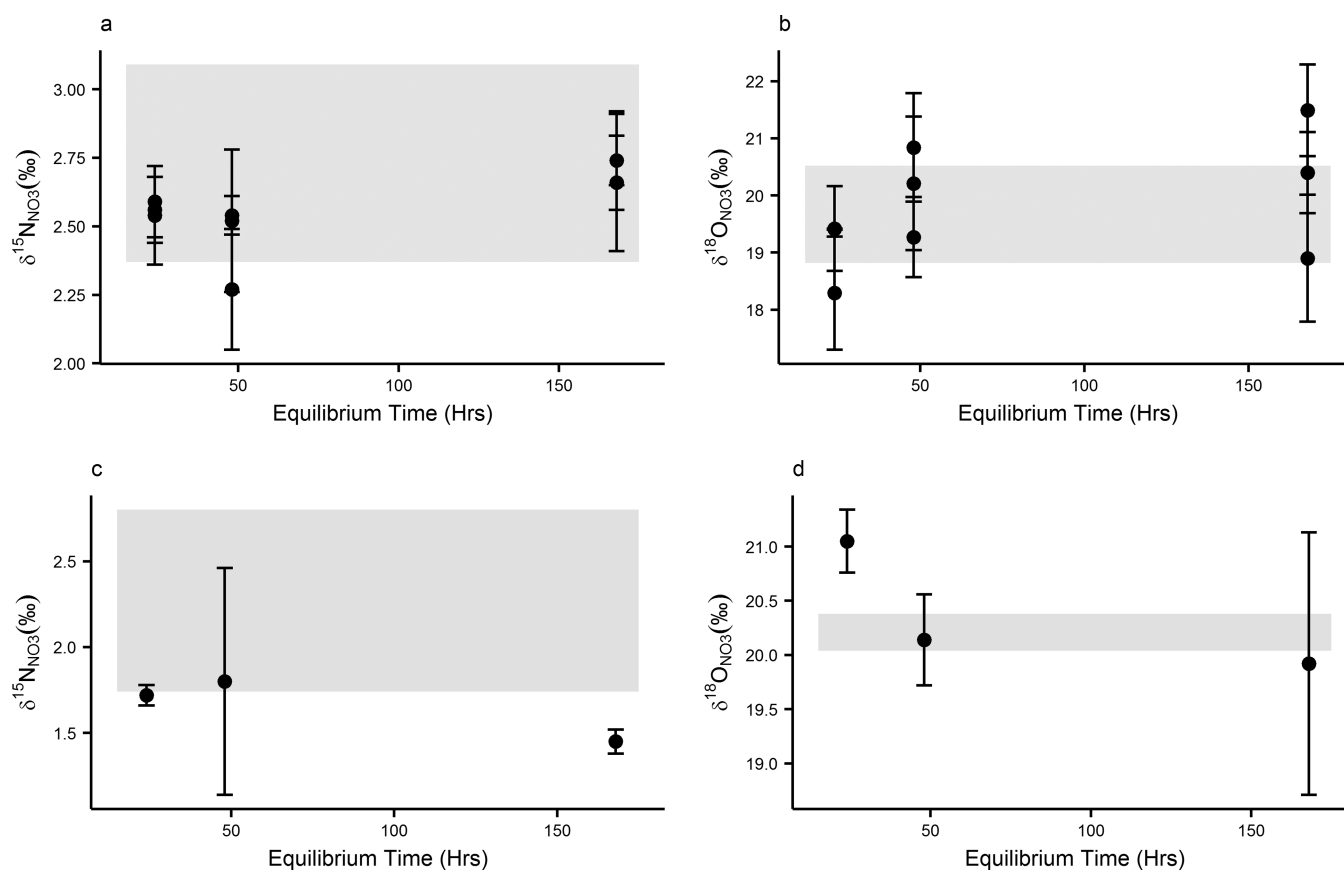

Figure 2. a. $\delta^{15}\text{N}_{\text{NO}_3}$ plotted against equilibrium time for DET gel solutions equilibrated in KNO₃ solutions, b. $\delta^{18}\text{O}_{\text{NO}_3}$ plotted against equilibrium time for DET gel solutions equilibrated in KNO₃ solutions, c. $\delta^{15}\text{N}_{\text{NO}_3}$ plotted against equilibrium time for DET gel solutions equilibrated in nitrate-spiked river solutions, d. $\delta^{18}\text{O}_{\text{NO}_3}$ plotted against equilibrium time for DET gel solutions equilibrated in nitrate-spiked river solutions. The gray shaded areas represent the measurement error of the stock solutions used for equilibration ($\sigma = 1$).

were all between 90.4 and 112.1%, and we believe the differences to come from varying dilution factors between the lowest and highest concentrations used, as solutions of 7.0 g NO₃⁻ L⁻¹ were diluted by the same factor, which was twice that of the solutions of concentration 3.3 and 4.8 g NO₃⁻ L⁻¹, which were also diluted by the same factor, to allow for machine analysis. The nitrate recoveries observed were, therefore, independent of initial solution concentration. This was supported by the independence of recovery and initial solution concentration when performing the environmentally relevant concentration experiments (Table S-1). These yielded nitrate recoveries between 99.4 and 105.2%, showing that equilibrium was reached in each case. A fitted linear model gave an adjusted R² value of -0.3 and a p-value of 0.64, showing that the nitrate recovery was independent of initial solution concentration.

The independence from equilibration time evidenced that as long as equilibrium is reached, the time the gel is left in solution should not affect nitrate recovery, and that the DET gels were expected to equilibrate by 24 h. When utilizing the DET gels *in situ* the deployment time should be longer than the equilibrium time required for the gel thickness used. This is because the natural conditions of the system need to be re-established after gel deployment. Field deployment times for DET gels of 72 h have been recommended previously.¹⁴

The high nitrate concentrations used in these experiments (up to 7.0 g NO₃⁻ L⁻¹) resulted from practical limitations of the isotope analysis method used in the proof-of-concept study, which required a minimum of 1 mg of NO₃⁻-N. As evidenced

by our results, these high concentrations did not prevent the reaching of equilibrium by diffusion into the gel. This proves that DET gels can also be applied in high nitrate conditions (e.g., artificial wetlands, wastewater treatment plant outputs), as the recovery of nitrate was not dependent on the solution concentration. It is acknowledged that the large nitrate concentrations used here, due to method limitations, are much higher than those found in most natural environments; therefore, the experiment was repeated with environmentally relevant concentrations as discussed above.

Nitrate Isotope Ratios in DET Gels. $\delta^{15}\text{N}_{\text{NO}_3}$. The $\delta^{15}\text{N}_{\text{NO}_3}$ for the nitrate solutions were the same as that of the stock solution, within error, with a range between $2.3 \pm 0.2\text{‰}$ and $2.7 \pm 0.1\text{‰}$, compared with $2.7 \pm 0.4\text{‰}$ of the stock (Figure 2). The nitrate-spiked river water had a different $\delta^{15}\text{N}_{\text{NO}_3}$ value, $2.3 \pm 0.5\text{‰}$, than that of the nitrate solutions; this was expected as distinct sources of nitrate have different $\delta^{15}\text{N}_{\text{NO}_3}$ and $\delta^{18}\text{O}_{\text{NO}_3}$ values. The $\delta^{15}\text{N}_{\text{NO}_3}$ for the river solutions equilibrated for 24 and 48 h were found to be the same as the stock, within error, with $\delta^{15}\text{N}_{\text{NO}_3}$ of $1.8 \pm 0.7\text{‰}$ and $1.7 \pm 0.1\text{‰}$, respectively. $\delta^{15}\text{N}_{\text{NO}_3}$ for 168-h equilibrium time was lower than the stock with a value of $1.5 \pm 0.1\text{‰}$; however, this was not a statistically significant difference (paired *t* test, p-value = 0.16).

$\delta^{18}\text{O}_{\text{NO}_3}$. The $\delta^{18}\text{O}_{\text{NO}_3}$ of the nitrate solutions were predominantly found to be the same as that of the stock solution, within error, with a range between $18.3 \pm 1.0\text{‰}$ and $20.8 \pm 1.0\text{‰}$, compared with $19.7 \pm 0.9\text{‰}$ of the stock (Figure

2). The measured $\delta^{18}\text{O}_{\text{NO}_3}$ value for the 168-h equilibrium time with a stock solution of $4.8 \text{ mg NO}_3^- \text{ L}^{-1}$ was higher than the stock at $\delta^{18}\text{O}_{\text{NO}_3} 21.5 \pm 0.8\text{‰}$; however, this was not a statistically significant difference (paired t test, p -value = 0.095). The $\delta^{18}\text{O}_{\text{NO}_3}$ for the river solutions equilibrated for 48 and 168 h was found to be the same as the stock, within error, with $\delta^{18}\text{O}_{\text{NO}_3}$ of $19.9 \pm 1.2\text{‰}$ and $20.1 \pm 0.4\text{‰}$, respectively, compared with $20.2 \pm 0.2\text{‰}$ of the stock. $\delta^{18}\text{O}_{\text{NO}_3}$ for 24-h equilibrium time was higher than the stock at $21.1 \pm 0.3\text{‰}$, and this was found to be statistically significant (paired t test, p -value = 0.01).

This is believed to be due to the unusually small measurement error in the stock solution (0.2‰), as the lowest value the 24-h sample could be is 20.8‰ and the highest value the stock could be is 20.4‰, which are similar values and would not otherwise be interpreted as having fractionated. This is evidenced by the uncertainty found in the IAEA- NO_3 standard of 0.85 and 1.46‰ (from multiple analyses), showing that two results within this range cannot be distinguished using this technique.

Determination of Fractionation. The analysis of $\delta^{15}\text{N}_{\text{NO}_3}$ and $\delta^{18}\text{O}_{\text{NO}_3}$ revealed no significant difference between the values of the stock solution and those of the gel solutions. We, therefore, found no evidence of fractionation during the process of nitrate diffusion into and out of the gel during equilibrium and elution. This also demonstrates that solution concentration and equilibrium time did not affect $\delta^{15}\text{N}_{\text{NO}_3}$ and $\delta^{18}\text{O}_{\text{NO}_3}$ (Figure 2). There was also no relationship between the $\delta^{15}\text{N}_{\text{NO}_3}$ and $\delta^{18}\text{O}_{\text{NO}_3}$ of the gel solution and nitrate recovery, with fitted linear models for the KNO_3 for $\delta^{15}\text{N}_{\text{NO}_3}$ and $\delta^{18}\text{O}_{\text{NO}_3}$ with adjusted R^2 values of -0.050 and 0.058 , and p -values of 0.46 and 0.26 , respectively, and fitted linear models for the river samples with adjusted R^2 values of -0.80 and -0.051 , and p -values of 0.79 and 0.52 , respectively. This again indicated that equilibrium was reached, and no fractionation was caused by diffusion (Figure S-2).

This was also shown in most cases for additional environmentally relevant concentration experiments (outlined previously). Gel solutions of NO_3^- had $\delta^{15}\text{N}_{\text{NO}_3}$ values between 0.1 ± 0.3 and $0.5 \pm 0.3\text{‰}$ for a stock value of $0.1 \pm 0.3\text{‰}$ and a $\delta^{18}\text{O}_{\text{NO}_3}$ value for a $100.5 \text{ mg NO}_3 \text{ L}^{-1}$ solution of $22.3 \pm 0.4\text{‰}$ for a stock value of $22.0 \pm 0.4\text{‰}$. The $\delta^{18}\text{O}_{\text{NO}_3}$ values for 20.1 and $50.8 \text{ mg NO}_3 \text{ L}^{-1}$ solutions were outside of the stock's error, both having values of $23.0 \pm 0.4\text{‰}$. These were found to be significantly different than the stock (paired t test, p -value = 0.022 and 0.000 , respectively, for 20.1 and $50.8 \text{ mg NO}_3 \text{ L}^{-1}$); however, this is believed to be due to the small standard deviation of sample replicates ($n = 3$), of 0.2 , 0.0 , and 0.0‰ , respectively, for 20.1 and $50.8 \text{ mg NO}_3 \text{ L}^{-1}$, and the stock. Given that the difference between the highest value the stock ratio could be and the lowest value the solution ratio could be is only 0.2 for both solutions, this would not usually be considered fractionated. This is evidenced by the long-term reproducibility of the isotope technique, which is $\pm 0.4\text{‰}$, showing that two results within this range cannot be distinguished using this technique. The river sample had a $\delta^{15}\text{N}_{\text{NO}_3}$ value of $10.3 \pm 0.3\text{‰}$ for a stock of $10.2 \pm 0.3\text{‰}$ and a $\delta^{18}\text{O}_{\text{NO}_3}$ value of $4.7 \pm 0.4\text{‰}$ for a stock of $4.2 \pm 0.4\text{‰}$.

The nitrate-spiked river samples were used to test for any matrix effects, which may affect $\delta^{15}\text{N}_{\text{NO}_3}$ and $\delta^{18}\text{O}_{\text{NO}_3}$ values when this method is utilized *in situ*. There was no fractionation of $\delta^{15}\text{N}_{\text{NO}_3}$ and $\delta^{18}\text{O}_{\text{NO}_3}$ in the river water samples, confirming

the applicability of this method in environments where interfering ions are present.

Concentration and Isotope Analysis from *in Situ* DET Application. Three example profiles of *in situ* DET sampling are discussed as proof of concept for the proposed combined DET-isotope methodology. The DET gels captured a large range of nitrate concentrations and $\delta^{15}\text{N}_{\text{NO}_3}$ and $\delta^{18}\text{O}_{\text{NO}_3}$ values in a 15 cm profile (Table S-2, Figure 3), with all nitrate concentrations from the DET gels (18.6 ± 0.1 to $82.5 \pm 0.9 \text{ mg NO}_3^- \text{ L}^{-1}$) greater than that of the average inflow concentration of nitrate ($13.4 \pm 0.7 \text{ mg NO}_3^- \text{ L}^{-1}$).

The largest concentration range was observed in gel 2, with a minimum of $20.0 \pm 0.1 \text{ mg NO}_3^- \text{ L}^{-1}$ at 11 cm depth to a maximum of $82.5 \pm 0.9 \text{ mg NO}_3^- \text{ L}^{-1}$ at 1.25 cm depth. The largest range of $\delta^{15}\text{N}_{\text{NO}_3}$ and $\delta^{18}\text{O}_{\text{NO}_3}$ was shown in gels 1 and 2, respectively. $\delta^{15}\text{N}_{\text{NO}_3}$ values in gel 1 ranged from $0.2 \pm 0.3\text{‰}$ at 11 cm depth to $17.9 \pm 0.3\text{‰}$ at 3.75 cm depth, and $\delta^{18}\text{O}_{\text{NO}_3}$ values in gel 2 ranged from $-9.9 \pm 0.4\text{‰}$ at 1.25 cm depth to $9.3 \pm 0.4\text{‰}$ at 6.25 cm depth. These results highlight the ability of DET gel-based passive sampling to capture hotspots of biogeochemical activity and spatially small redox zones, which would be missed with more traditional methods i.e. multilevel piezometers, as was found previously with nitrate concentrations.¹⁴ This is particularly shown in profile 1, where there appears to be an area of denitrification at 3.75 cm , indicated by low nitrate concentration combined with high $\delta^{15}\text{N}_{\text{NO}_3}$ and $\delta^{18}\text{O}_{\text{NO}_3}$ values. Concentrations at all depths in gel 1 vary over a small range between 37.3 ± 0.4 and $47.4 \pm 0.4 \text{ mg NO}_3^- \text{ L}^{-1}$, except for at a depth of 3.75 cm , where the concentration has decreased to $18.6 \pm 0.1 \text{ mg NO}_3^- \text{ L}^{-1}$.

This is also reflected in the isotopic data where $\delta^{15}\text{N}_{\text{NO}_3}$ varies over a small range between $0.2 \pm 0.3\text{‰}$ and $3.3 \pm 0.3\text{‰}$, except at 3.75 cm , where the $\delta^{15}\text{N}_{\text{NO}_3}$ value has increased to $17.9 \pm 0.3\text{‰}$, and $\delta^{18}\text{O}_{\text{NO}_3}$ varies over a small range between $-2.3 \pm 0.4\text{‰}$ and $-3.5 \pm 0.4\text{‰}$, except at 3.75 cm where the $\delta^{18}\text{O}_{\text{NO}_3}$ value has increased to $11.4 \pm 0.4\text{‰}$.

The analysis of vertical profiles of nitrate isotope ratios and concentrations indicates differences in concentration patterns at the three locations (Figure 3). Gel 1 shows slightly higher concentrations at greatest depths (43.4 ± 0.5 to $47.4 \pm 0.4 \text{ mg NO}_3^- \text{ L}^{-1}$) compared to the shallowest depth ($37.3 \pm 0.4 \text{ mg NO}_3^- \text{ L}^{-1}$), with a local minimum of $18.6 \pm 0.1 \text{ mg NO}_3^- \text{ L}^{-1}$ at 3.75 cm . This could be due to zones of nitrification associated with the mineralization of nitrogen from the macrophytes.^{14,27–29} The $\delta^{15}\text{N}_{\text{NO}_3}$ and $\delta^{18}\text{O}_{\text{NO}_3}$ profiles show little variation with depth, only varying between $0.2 \pm 0.3\text{‰}$ and $3.3 \pm 0.3\text{‰}$ and $-2.3 \pm 0.4\text{‰}$ and $-3.5 \pm 0.4\text{‰}$, respectively, except at 3.75 cm where there is a large increase in $\delta^{15}\text{N}_{\text{NO}_3}$ to $17.9 \pm 0.3\text{‰}$ and $\delta^{18}\text{O}_{\text{NO}_3}$ to $11.4 \pm 0.4\text{‰}$. Although similar, $\delta^{15}\text{N}_{\text{NO}_3}$ values between 6.25 and 11 cm depth do decrease with depth, perhaps pointing to the onset of denitrification at 6.25 cm depth. The combination of low nitrate concentration, with high $\delta^{15}\text{N}_{\text{NO}_3}$ and $\delta^{18}\text{O}_{\text{NO}_3}$ values, is indicative of denitrification; therefore, there appears to be a localized zone of denitrification at 3.75 cm .³⁰

In gel 2 an overall decrease in nitrate was observed at greater depths than in gel 1, although there was a concentration of $46.9 \pm 0.3 \text{ mg NO}_3^- \text{ L}^{-1}$ at 14.25 cm , which was intermediate of the concentrations found at 1.25 and 3.75 cm (82.5 ± 0.9 and $72.4 \pm 0.7 \text{ mg NO}_3^- \text{ L}^{-1}$, respectively) and 6.25 to 11 cm (20.0 ± 0.1 to $22.4 \pm 0.2 \text{ mg NO}_3^- \text{ L}^{-1}$). The $\delta^{15}\text{N}_{\text{NO}_3}$ values showed little variation between the shallowest and the largest depth; $\delta^{15}\text{N}_{\text{NO}_3}$ was slightly higher at the greatest depth than at the

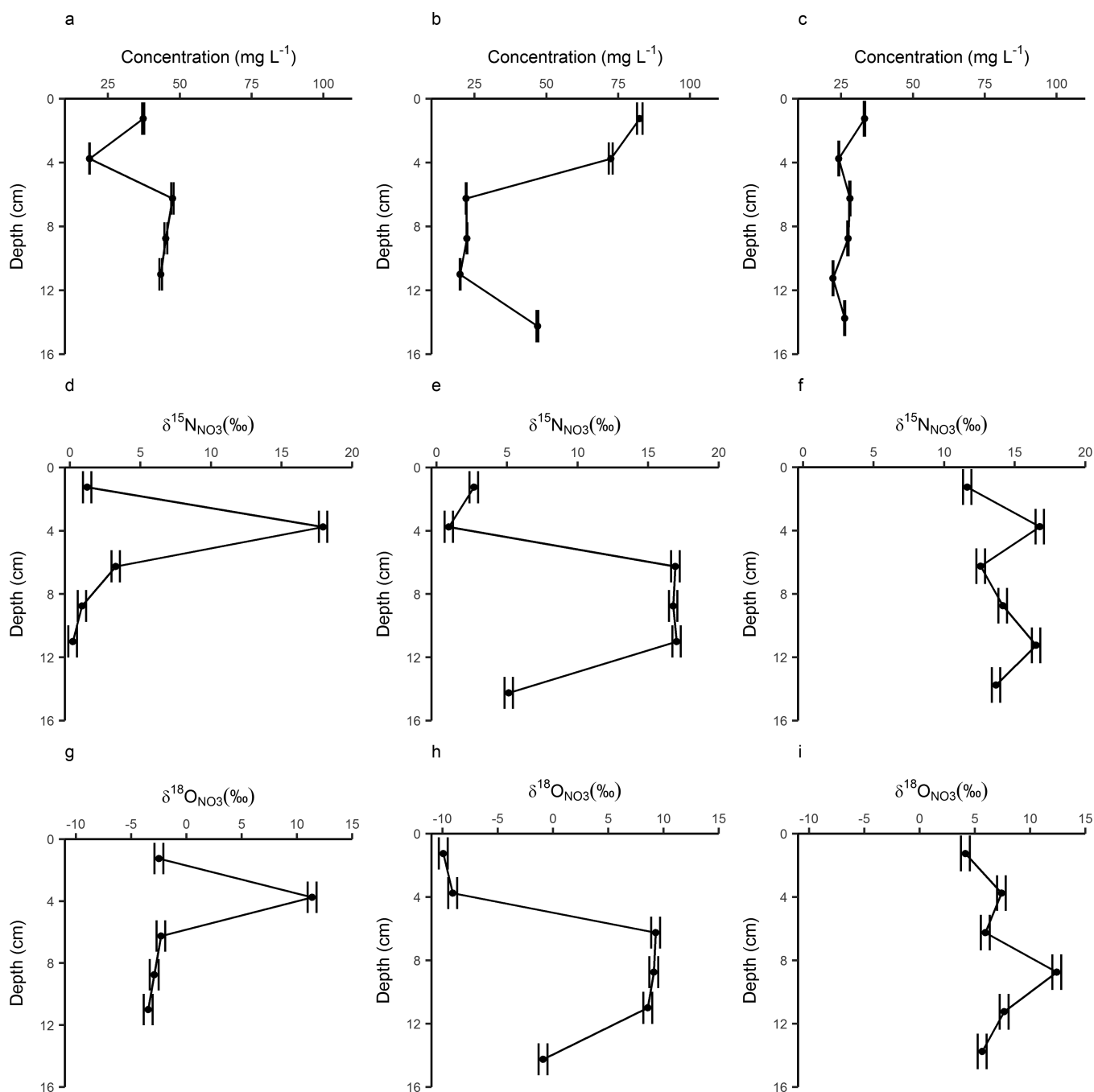

Figure 3. DET gel profiles from an *in situ* deployment in gravel-filled mesocosms at the Urban River Laboratory, Montornès del Vallès Wastewater Treatment Plant, Montornès del Vallès, Spain. a-c. Concentration of nitrate plotted against depth for gels 1–3, d-f. $\delta^{15}\text{N}_{\text{NO}_3}$ ratios plotted against depth for gels 1–3, g-i. $\delta^{18}\text{O}_{\text{NO}_3}$ ratios plotted against depth for gels 1–3.

shallowest depth, with values of $5.1 \pm 0.3\text{‰}$ and $2.7 \pm 0.3\text{‰}$, respectively, and the lowest $\delta^{15}\text{N}_{\text{NO}_3}$ value of $0.9 \pm 0.3\text{‰}$ was found at 3.75 cm depth. The shallowest depth $\delta^{18}\text{O}_{\text{NO}_3}$ values were also lower than at the greatest depth; however, the difference from $-9.9 \pm 0.4\text{‰}$ to $-0.9 \pm 0.4\text{‰}$ was greater than seen for $\delta^{15}\text{N}_{\text{NO}_3}$. A substantial increase in $\delta^{15}\text{N}_{\text{NO}_3}$ values was observed between 6.25 and 11 cm depth, with values between 16.8 ± 0.3 and $16.9 \pm 0.3\text{‰}$. This large increase was also present in the $\delta^{18}\text{O}_{\text{NO}_3}$ profile, where peak concentrations ranged between $8.6 \pm 0.4\text{‰}$ and $9.3 \pm 0.4\text{‰}$, between 6.25 and 11 cm. In combination with $\delta^{15}\text{N}_{\text{NO}_3}$ and $\delta^{18}\text{O}_{\text{NO}_3}$ values,

the concentrations observed at these depths indicate denitrification.

Vertical variation of nitrate concentrations in gel 3 seems to be minimal, with a narrow concentration range of 22.2 ± 0.2 to $33.1 \pm 0.2 \text{ mg NO}_3^- \text{ L}^{-1}$ for the whole 15 cm gel. It is worth noting that the maximum concentration found in gel 3 is at 1.25 cm, which is the same as is found in gel 2. The $\delta^{15}\text{N}_{\text{NO}_3}$ and $\delta^{18}\text{O}_{\text{NO}_3}$ values in gel 3 did not cover as wide a range as in gels 1 and 2; the range in $\delta^{15}\text{N}_{\text{NO}_3}$ and $\delta^{18}\text{O}_{\text{NO}_3}$ here was just 11.6 ± 0.3 to $16.8 \pm 0.3\text{‰}$ and 4.1 ± 0.4 to $12.4 \pm 0.4\text{‰}$, respectively. $\delta^{15}\text{N}_{\text{NO}_3}$ values showed little variation ranging from 11.6 ± 0.3 to $14.2 \pm 0.3\text{‰}$, at all depths except 3.75 and

11.25 cm, where two areas of higher $\delta^{15}\text{N}_{\text{NO}_3}$ values were found, with values of 16.8 ± 0.3 and $16.5 \pm 0.3\%$, respectively. These high $\delta^{15}\text{N}_{\text{NO}_3}$ values at 3.75 and 11.25 cm were not reflected in the $\delta^{18}\text{O}_{\text{NO}_3}$ data, which showed a higher $\delta^{18}\text{O}_{\text{NO}_3}$ value of $12.4 \pm 0.4\%$ at 8.75 cm depth, with all other depths having similar $\delta^{18}\text{O}_{\text{NO}_3}$ values between 4.1 ± 0.4 and $7.7 \pm 0.4\%$. The profile shows low nitrate concentrations with high $\delta^{15}\text{N}_{\text{NO}_3}$ and $\delta^{18}\text{O}_{\text{NO}_3}$ values for all depths, indicating denitrification throughout the profile. Considering $\delta^{15}\text{N}_{\text{NO}_3}:\delta^{18}\text{O}_{\text{NO}_3}$ is also useful in identifying areas of denitrification, a ratio between approximately 2.1 and 2.5 is considered indicative of denitrification.¹⁰ In gel 3 this ratio is found at depths of 3.75, 6.25, 11.25, and 13.75 cm, where the $\delta^{15}\text{N}_{\text{NO}_3}:\delta^{18}\text{O}_{\text{NO}_3}$ is 2.3, 2.1, 2.2, and 2.4, respectively, providing further evidence of denitrification. This denitrification throughout the profile is likely related to an overall increase in denitrification toward the downstream end of the flume as the residence time of the porewater and nitrate increased, and due to the cumulative effect of vegetation described previously.

Generally, enhanced denitrification appears to be correlated with the occurrence of vegetation in the flume, which has been previously observed to particularly affect depths between 5 and 12 cm.^{27,28} Possible mechanisms by which vegetation enhances sediment denitrification can be of biotic or abiotic nature, generally leading to high biogeochemical reactivity.³¹ These include, uptake by macrophytes, increased surface water downwelling, and enhanced residence times of water in the sediment that are facilitated by vegetation and may, therefore, have led to the increased denitrification seen here.^{3,28} Similar zones of vegetation-associated denitrification were found in the River Leith, U.K.²⁸ Nitrate concentrations ranging from 0.05 to 7.31 mg NO_3^- -N L^{-1} were found in vegetated areas, compared to 0.41 to 9.83 mg NO_3^- -N L^{-1} in nonvegetated areas, indicating denitrification associated with the vegetation.

Horizontal patterns along the flume indicate a general trend of denitrification with an increased observation of low nitrate concentration samples from gel 3 through to gel 1, combined with an increased frequency of high $\delta^{15}\text{N}_{\text{NO}_3}$ and $\delta^{18}\text{O}_{\text{NO}_3}$ values. This longitudinal profile is overlain by local effects, where hotspots of biogeochemical reactivity can be seen, thought to be influenced by the vegetation effect described previously. Comparing the gel data to the nitrate concentration of the inflow shows an increase in nitrate from the inflow to the subsurface water of the flume, indicating net nitrification within the flume itself. This is the opposite of the denitrification trend shown by the gel profiles and seems to show high nitrification within the flume, even upstream of the first gel, which increased nitrate concentrations before these decreased again through denitrification.

The *in situ* results of the DET gel and isotope method presented here have allowed the investigation of detailed processes at a spatial scale, which exceeds that of previous studies. Particularly, hotspots of denitrification were easily identified using both concentration and isotope data. The isotopic data were invaluable in showing that the gel profiles indicated generally high nitrate concentrations, with zones of denitrification leading to low nitrate concentrations. This is in contrast to the concentration data alone, which, along with the inflow concentration, indicates varying degrees of nitrification in the gel profiles. This is increasingly important in the study of nutrient fate at aquifer and river or lake interfaces; research areas that are often limited by a lack of sufficient monitoring

methods. Thus, this field trial has successfully demonstrated the value of this new approach for *in situ* applications.

To assess natural waters in which this DET-isotope technique could be applied, the concentration of nitrate in porewaters needed to provide a solution of 50 nmol NO_3^- required to perform the isotope analysis was calculated. Using a 1.56 mm thick DET gel and slicing at 1 cm would require a porewater nitrate concentration of 10.5 mg L^{-1} , and slicing at 2.5 cm would reduce this to 4.2 mg NO_3^- L^{-1} . The nitrate concentrations required limit this technique to sediments in nonpristine environments.^{3,32}

CONCLUSIONS

The laboratory proof of concept demonstrates that $\delta^{15}\text{N}_{\text{NO}_3}$ and $\delta^{18}\text{O}_{\text{NO}_3}$ do not fractionate when sampled with a DET gel. Nitrate recovery and $\delta^{15}\text{N}_{\text{NO}_3}$ and $\delta^{18}\text{O}_{\text{NO}_3}$ values were independent of both equilibrium time and nitrate concentration, suggesting the applicability of DET technology for sampling isotope ratios from sediment pore-water at high spatial resolution.

Additionally, the *in situ* application of DET gel probes in a field trial provides evidence of the potential of this methodology to sample nitrate concentration and isotopic data with DET technology in the field at higher resolution than previously possible.

Based on the promising results of the presented lab and field trials we recommend the application of this combined methodology at aquifer-river and aquifer-lake interfaces in order to enhance mechanistic process understanding of hotspots in nitrogen cycling. Future research may elaborate to what degree the application of the proposed methodologies can be extended also to brackish and marine systems.

ASSOCIATED CONTENT

Supporting Information

The Supporting Information is available free of charge on the ACS Publications website at DOI: 10.1021/acs.analchem.7b00028.

Tables S-1 and S-2 and figures showing nitrate recovery against equilibrium time and nitrate concentration (Figure S-1) and nitrate recovery against nitrate isotope values (Figure S-2) (PDF)

AUTHOR INFORMATION

Corresponding Author

*E-mail: sxc469@bham.ac.uk.

ORCID

Sophie A. Comer-Warner: 0000-0003-1260-3151

Jan Kaiser: 0000-0002-1553-4043

Present Addresses

[†]School of Geography, Earth and Environmental Sciences, University of Birmingham, Edgbaston, Birmingham B15 2TT, U.K.

[#]School of Life Sciences, Gibbet Hill Campus, The University of Warwick, Coventry CV4 7AL, U.K.

Notes

The authors declare no competing financial interest.

ACKNOWLEDGMENTS

The authors would like to thank Dr. Tim Heaton at the NERC Isotope Geoscience Laboratory (NIGL) for his help in sample

analysis and data interpretation, Dr. Eugènia Martí at CEAB and the Urban River Laboratory for allowing us to use their facilities and data, and Dr. Hao Zhang of DGT Research and Lancaster Environment Centre, University of Lancaster, for providing the DET gels and advice on the gel's capabilities. We would also like to thank the Natural Environment Research Council (NERC) and the Central England NERC Training Alliance for their funding of this project, as well as the NIGL for providing an in-kind grant for isotopic analysis.

REFERENCES

- (1) McClain, M. E.; Boyer, E. W.; Dent, C. L.; Gergel, S. E.; Grimm, N. B.; Groffman, P. M.; Hart, S. C.; Harvey, J. W.; Johnston, C. A.; Mayorga, E.; et al. *Ecosystems* **2003**, *6* (4), 301–312.
- (2) Lautz, L. K.; Fanelli, R. M. *Biogeochemistry* **2008**, *91*, 85–104.
- (3) Krause, S.; Tecklenburg, C.; Munz, M.; Naden, E. J. *Geophys. Res.: Biogeosci.* **2013**, *118* (1), 54–67.
- (4) Krause, S.; Boano, F.; Cuthbert, M. O.; Fleckenstein, J. H.; Lewandowski, J. *Water Resour. Res.* **2014**, *50* (2), 1847–1855.
- (5) Krause, S.; Hannah, D. M.; Fleckenstein, J. H.; Heppell, C. M.; Kaeser, D.; Pickup, R.; Pinay, G.; Robertson, A. L.; Wood, P. J. *Ecology* **2011**, *4* (4), 481–499.
- (6) Boano, F.; Harvey, J. W.; Marion, A.; Packman, A. I.; Revelli, R.; Ridolfi, L.; Wörman, A. *Rev. Geophys.* **2014**, *52* (4), 603–679.
- (7) Hannah, D. M.; Sadler, J. P.; Wood, P. J. *Hydrol. Processes* **2007**, *21*, 3385–3390.
- (8) Krause, S.; Heathwaite, L.; Binley, A.; Keenan, P. *Hydrol. Processes* **2009**, *23*, 2195–2211.
- (9) Krause, S.; Hannah, D. M.; Fleckenstein, J. H. *Hydrol. Processes* **2009**, *23*, 2103–2107.
- (10) Kendall, C. *Isotope Tracers in Catchment Hydrology* **1998**, *1000*, 519–576.
- (11) Abbott, B. W.; Baranov, V.; Mendoza-Lera, C.; Nikolakopoulou, M.; Harjung, A.; Kolbe, T.; Balasubramanian, M. N.; Vaessen, T. N.; Ciocca, F.; Campeau, A.; et al. *Earth-Sci. Rev.* **2016**, *160*, 19–42.
- (12) Lewandowski, J.; Nützmann, G. *Ecol. Eng.* **2010**, *36* (9), 1156–1166.
- (13) Welti, N.; Bondar-Kunze, E.; Singer, G.; Tritthart, M.; Zechmeister-Boltenstern, S.; Hein, T.; Pinay, G. *Ecol. Eng.* **2012**, *42* (August 2015), 73–84.
- (14) Ullah, S.; Zhang, H.; Heathwaite, A. L.; Binley, A.; Lansdown, K.; Heppell, K.; Trimmer, M. *Ecol. Eng.* **2012**, *49*, 18–26.
- (15) Mendoza-Lera, C.; Datry, T. *Sci. Total Environ.* **2017**, *579*, 1815–1821.
- (16) Krom, M. D.; Davison, P.; Zhang, H.; Davison, W. *Limnol. Oceanogr.* **1994**, *39*, 1967–1972.
- (17) Mortimer, R. J.; Krom, M. D.; Hall, P. O. J.; Hulth, S.; Ståhl, H. *Mar. Chem.* **1998**, *63* (1–2), 119–129.
- (18) Docekalova, H.; Clarisse, O.; Salomon, S.; Wartel, M. *Talanta* **2002**, *57* (1), 145–155.
- (19) Palmer-Felgate, E. J.; Mortimer, R. J. G.; Krom, M. D.; Jarvie, H. P. *Environ. Sci. Technol.* **2010**, *44* (3), 908–914.
- (20) Metzger, E.; Thibault de Chanvalon, A.; Cesbron, F.; Barbe, A.; Launeau, P.; Jézéquel, D.; Mouret, A. *Environ. Sci. Technol.* **2016**, *50* (15), 8188–8195.
- (21) Kessler, A. J.; Glud, R. N.; Cardenas, M. B.; Cook, P. L. M. *Environ. Sci. Technol.* **2013**, *47* (23), 13404–13411.
- (22) Roberts, K. L.; Kessler, A. J.; Grace, M. R.; Cook, P. L. M. *Geochim. Cosmochim. Acta* **2014**, *133*, 313–324.
- (23) Chang, C. C.; Langston, J.; Riggs, M.; Campbell, D. H.; Silva, S. R.; Kendall, C. *Can. J. Fish. Aquat. Sci.* **1999**, *56*, 1856–1864.
- (24) Heaton, T. H. E.; Wynn, P.; Tye, A. M. *Atmos. Environ.* **2004**, *38* (33), 5611–5621.
- (25) Casciotti, K. L.; Sigman, D. M.; Hastings, M. G.; Bohlke, J. K.; Hilke, A. *Anal. Chem.* **2002**, *74* (19), 4905–4912.
- (26) Sigman, D.; Karsh, K.; Casciotti, K. *Encycl. Ocean Sci.* **2009**, 4138–4153.
- (27) Byrne, P.; Zhang, H.; Ullah, S.; Binley, A.; Heathwaite, A. L.; Heppell, C. M.; Lansdown, K.; Trimmer, M. *Hydrol. Process* **2015**, *29*, 1385–1396.
- (28) Ullah, S.; Zhang, H.; Heathwaite, A. L.; Heppell, C.; Lansdown, K.; Binley, A.; Trimmer, M. *Biogeochemistry* **2014**, *118* (1–3), 121–134.
- (29) Mortimer, R. J. G.; Krom, M. D.; Harris, S. J.; Hayes, P. J.; Davies, I. M.; Davison, W.; Zhang, H. *Mar. Ecol.: Prog. Ser.* **2002**, *236*, 31–35.
- (30) Amberger, A.; Schmidt, H.-L. *Geochim. Cosmochim. Acta* **1987**, *51*, 2699–2705.
- (31) Forshay, K. J.; Dodson, S. I. *Hydrobiologia* **2011**, *668* (1), 21–34.
- (32) Lefebvre, S.; Marmonier, P.; Pinay, G. *River Res. Appl.* **2004**, *20* (5), 499–512.