

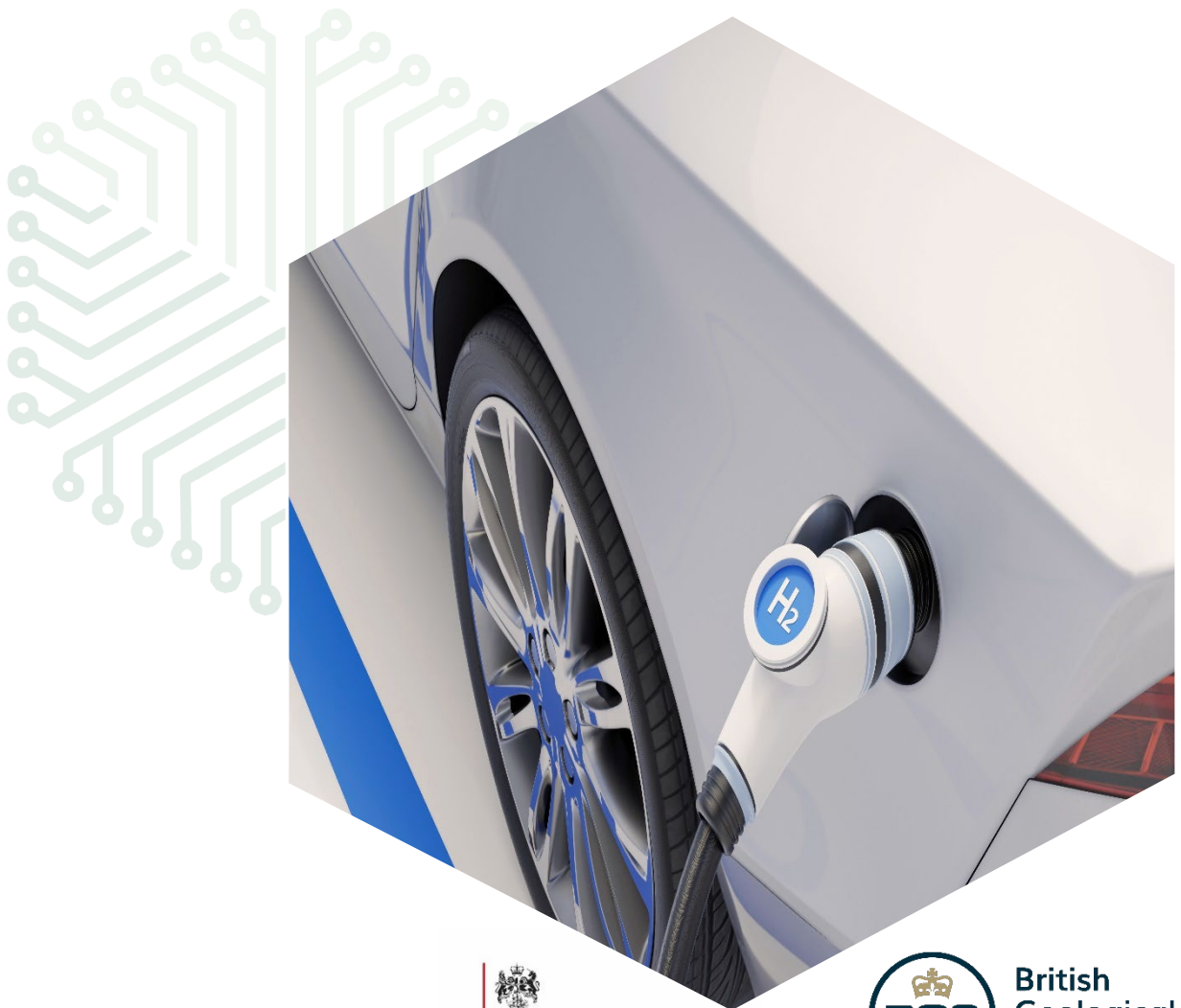



UK Critical Minerals
Intelligence Centre

Scoping report on the material requirements for a UK hydrogen economy

Decarbonisation and Resource Management Programme
Open Report OR/23/017



Department for
Business & Trade

 British
Geological
Survey

This report does not constitute government policy.

BRITISH GEOLOGICAL SURVEY

DECARBONISATION AND RESOURCE MANAGEMENT PROGRAMME
OPEN REPORT OR/23/017

Keywords

UK, hydrogen, platinum, iridium, PGM, electrolyser, fuel cells, PEM.

Front cover

Hydrogen refuelling,
©Microsoft 365

Bibliographical reference

F PRICE 2023. Scoping report on the material requirements for a UK hydrogen economy. *British Geological Survey Open Report, OR/23/017.* 29pp.

Copyright in materials derived from the British Geological Survey's work is owned by UK Research and Innovation (UKRI) and/or the authority that commissioned the work. You may not copy or adapt this publication without first obtaining permission. Contact the BGS Intellectual Property Rights Section, British Geological Survey, Keyworth, e-mail ipr@bgs.ac.uk. You may quote extracts of a reasonable length without prior permission, provided a full acknowledgement is given of the source of the extract.

This report does not constitute government policy.

Scoping report on the material requirements for a UK hydrogen economy

F Price

Contributor/editor

M Bentham, D Condon

BRITISH GEOLOGICAL SURVEY

The full range of our publications is available from BGS shops at Nottingham, Edinburgh, London and Cardiff (Welsh publications only) see contact details below or shop online at www.geologyshop.com

The London Information Office also maintains a reference collection of BGS publications, including maps, for consultation.

We publish an annual catalogue of our maps and other publications; this catalogue is available online or from any of the BGS shops.

The British Geological Survey carries out the geological survey of Great Britain and Northern Ireland (the latter as an agency service for the government of Northern Ireland), and of the surrounding continental shelf, as well as basic research projects. It also undertakes programmes of technical aid in geology in developing countries.

The British Geological Survey is a component body of UK Research and Innovation.

British Geological Survey offices

**Nicker Hill, Keyworth,
Nottingham NG12 5GG**

Tel 0115 936 3100

BGS Central Enquiries Desk

Tel 0115 936 3143

email enquiries@bgs.ac.uk

BGS Sales

Tel 0115 936 3241

email sales@bgs.ac.uk

**The Lyell Centre, Research Avenue South,
Edinburgh EH14 4AP**

Tel 0131 667 1000

email scotsales@bgs.ac.uk

**Natural History Museum, Cromwell Road,
London SW7 5BD**

Tel 020 7589 4090

Tel 020 7942 5344/45

email bgs_london@bgs.ac.uk

**Cardiff University, Main Building, Park Place,
Cardiff CF10 3AT**

Tel 029 2167 4280

**Maclean Building, Crowmarsh Gifford,
Wallingford OX10 8BB**

Tel 01491 838800

**Geological Survey of Northern Ireland, Department for
the Economy, Dundonald House, Upper Newtownards
Road, Ballymiscaw, Belfast, BT4 3SB**

Tel 0289 038 8462

www2.bgs.ac.uk/gsni/

**Natural Environment Research Council, Polaris House,
North Star Avenue, Swindon SN2 1EU**

Tel 01793 411500

Fax 01793 411501

www.nerc.ac.uk

**UK Research and Innovation, Polaris House,
Swindon SN2 1FL**

Tel 01793 444000

www.ukri.org

Website www.bgs.ac.uk

Shop online at www.geologyshop.com

Foreword

Minerals will assume greater importance in contributing to the UK's economic growth and high standard of living over the coming decades. This will be driven by requirements for the UK to bring all greenhouse gas emissions to net zero by 2050, grow the advanced manufacturing sector, mitigate risks to national security, deliver economic prosperity and create opportunities for UK businesses in critical mineral supply chains domestically and internationally. This report has been produced by the British Geological Survey (BGS) under the auspices of the Department for Business & Trade-funded UK Critical Minerals Intelligence Centre (CMIC). The CMIC aims to provide up to date, accurate, high-resolution data and dynamic analysis on primary and secondary minerals resources, supply, stocks and flows of critical minerals, in the UK and globally. Its work supports delivery of the UK Critical Minerals Strategy that aims to improve the security of supply of critical minerals by accelerating the UK's domestic capabilities, collaborating with international partners, and enhancing international markets.

Acknowledgements

We would like to thank Margery Ryan, Andy Walker and Emma Schofield at Johnson Matthey for their input to the study, in particular the comments and feedback that they provided on the draft report and freely providing advice and specific knowledge. We appreciate their willingness to cooperate, and the time taken to review and contribute to the report.

Contents

Foreword.....	ii
Acknowledgements	ii
Contents.....	iii
Summary.....	1
1 Introduction.....	2
2 Hydrogen production	4
2.1 Electrolysis.....	4
2.2 Electrolyser installations.....	6
2.3 Electrolysers and critical minerals	7
3 Hydrogen applications	10
3.1 Fuel cells.....	10
3.2 Fuel cells and critical minerals.....	11
4 Platinum-group metal demand.....	12
4.1 Platinum	12
4.2 Iridium	13
4.3 Ruthenium.....	14
5 Platinum-group metal supply	14
5.1 Mine supply.....	15
5.2 Recycling	16
5.2.1 Recycling in the UK	17
6 Platinum-group metal reserves and resources.....	18
6.1 UK platinum-group metal resource potential.....	18
7 Trade of platinum-group metals	18
8 Other considerations	20
8.1 Transportation, distribution and storage	20
9 Summary.....	21
References.....	22

FIGURES

Figure 1. Hydrogen demand and proportion of final energy consumption in 2050. Source: BEIS, 2021. Contains public sector information licensed under the Open Government Licence v3.0.....	2
---	---

Figure 2. UK hydrogen projects. Source: DIT, 2022. Contains public sector information licensed under the Open Government Licence v3.0.....	3
Figure 3. Different types of electrolysis technologies. Source: IRENA, 2020	4
Figure 4. Estimated share of green hydrogen electrolyser technologies. Note: The UK project pipeline is estimated at 20GW (April 2022) based on plans and proposals for projects that are in the public domain. More projects are under development in all parts of the UK. Source: BEIS, 2022a and DIT, 2022. Contains public sector information licensed under the Open Government Licence v3.0.....	7
Figure 5. Cost breakdown for a 1 MW PEM electrolyser. Note: The specific breakdown varies by manufacturer, application, and location, but values in the figure represent an average. © 2020 IRENA.....	8
Figure 6. Cost breakdown for a 1 MW alkaline electrolyser. Note: The specific breakdown varies by manufacturer, application and location, but values in the figure represent an average. © 2020 IRENA.....	8
Figure 7. Electrolyser technology readiness. Source: IEA (2022b), modified by BGS.....	9
Figure 8. Schematic diagram of a fuel cell. BGS © UKRI.....	10
Figure 9. Summary of fuel cell types. SOFC – solid oxide fuel cells, MCFC – molten carbonate fuel cell, PAFC – phosphoric acid fuel cell, PEMFC – proton exchange membrane, AFC – alkaline fuel cell. BGS © UKRI.	11
Figure 10. Global platinum demand by sector 2022. Demand data © SFA (Oxford) 2023, used with permission.	13
Figure 11. Global iridium demand by sector 2022. Demand data © SFA (Oxford) 2023, used with permission.	13
Figure 12. Global ruthenium demand by sector 2022. Demand data © SFA (Oxford) 2023, used with permission.	14
Figure 13. Share of primary platinum, iridium and ruthenium production 2022. Production data © SFA (Oxford) 2023, used with permission.	15
Figure 14. Share of demanded material by source for materials for hydrogen. Note: vanadium and graphite were excluded due to lack of data on recycling rates. © 2022 The World Bank Group.....	17
Figure 15. Imports of platinum (HS 7110). RoW = Rest of World. Source: DESA/UNSD, 2023 (United Nations Comtrade database).	19
Figure 16. Imports of iridium, ruthenium and osmium (HS 711041). RoW = Rest of World. Source: DESA/UNSD, 2023 (United Nations Comtrade database).	19
Figure 17. Cumulative gross demand up to 2050 for aluminium, zinc, copper and nickel from renewable technologies associated with the hydrogen sector. © 2022 The World Bank Group.....	20

TABLES

Table 1. Electrolyser technologies compared. Critical raw materials, as identified in the UK Criticality Assessment (Lusty et al., 2021), are highlighted in red. © 2020 IRENA.....	6
---	---

Summary

This scoping study assesses the raw material demand associated with the scale-up of a UK hydrogen economy, with a particular focus on proton exchange membrane (PEM) electrolyser technology and platinum-group metals (PGM), specifically platinum and iridium. It considers their applications and importance; mineral production and supply chains; competing demands, and UK import reliance and key dependencies. It identifies potential supply-demand challenges and explores opportunities throughout the supply chain to ensure PGM supply can sustainably support PEM electrolyser growth. The research is based on a combination of literature review, analysis of trade statistics and stakeholder consultation.

In line with net zero ambitions, the UK has set a commitment for up to 10GW of low carbon hydrogen production capacity by 2030, with at least half of this from electrolytic hydrogen, produced through a process known as electrolysis. Low carbon hydrogen is expected to play a complementary and enabling role alongside other clean electricity sources in decarbonising our energy system. It is particularly well-suited to energy-intensive sectors where electrification is not feasible or too costly, such as high temperature heat in industrial furnaces and heavy-duty transport.

Electrolysis involves using electricity is used to split water into hydrogen and oxygen. Gas from this process is often referred to as 'green hydrogen' or zero carbon hydrogen when the electricity comes from renewable sources. PEM electrolysis is one of the technologies used to produce electrolytic hydrogen and it requires iridium- and platinum-based catalysts. PEM is expected to account for 70 per cent of electrolyser installations in the UK by 2030, largely owing to its inherent flexibility advantages associated with renewable power generation, which the UK has high ambitions to achieve.

The forecast demand for platinum from PEM scale up can be comfortably met by existing supply mechanisms (mine production and recycling). In contrast, demand projections for iridium at current loadings present a significant opportunity for optimisation through thrifting (using less metal), improved efficiencies and recycling.

Platinum and iridium production is highly geographically concentrated in South Africa, which also increases the risk of supply constraints and price volatility related to potential geopolitical events or disruption to logistics. However, the UK has a well-established PGM supply chain, with a long history of refining and recycling. Therefore, the challenges that typically exist for materials used in nascent end-use sectors are less of a consideration for platinum and iridium in the context of hydrogen. The UK also has good bilateral relations with several key producing regions, including a new Partnership on Minerals for Future Clean Energy Technologies with South Africa.

1 Introduction

At the 27th UN Climate Change Conference of the Parties (COP27) in 2022 parties resolved to pursue efforts to limit global temperature increase to 1.5°C, recognising this requires rapid and sustained reductions in greenhouse gas emissions through accelerated development, deployment and dissemination of clean power generation (UNFCCC, 2022).

The UK strengthened its Nationally Determined Contribution (NDC) to align with the Paris Agreement temperature goal (BEIS, 2022a) and has committed to reducing economy-wide greenhouse gas emissions by at least 68% by 2030 compared to 1990. As many industrial processes have already reached maximum attainable energy efficiency feasible in the current economic landscape, the growth and integration of a low carbon hydrogen economy is considered to be a key transformation needed to put countries to on a Paris Agreement-compatible pathway.

As part of a decarbonised energy system, low-carbon hydrogen could be a versatile replacement for high-carbon fuels used today – helping to reduce emissions in UK industries and providing flexible energy for power, transport and potentially heat. BEIS (now DESNZ) analysis indicated 250-460TWh of hydrogen could be needed by 2050 to meet its Carbon Six Budget and net zero goals, making up 20-35% of UK final energy consumption (Figure 1) (BEIS, 2021).

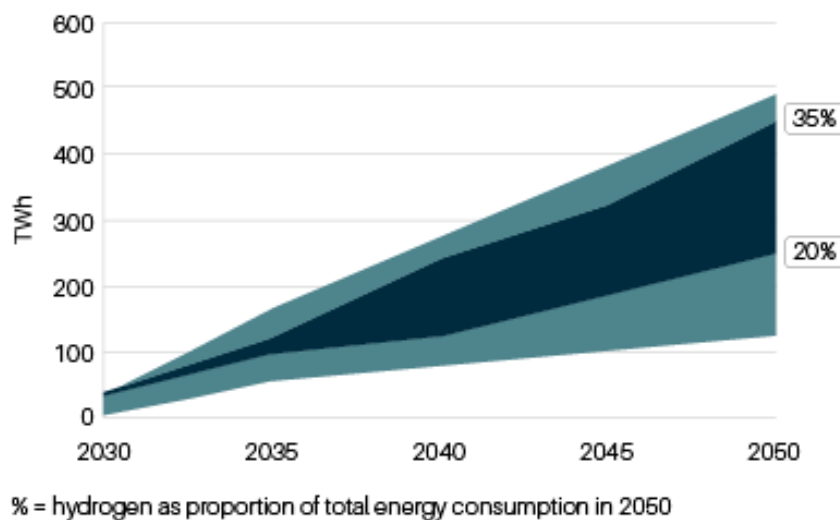

Figure 1. Hydrogen demand and proportion of final energy consumption in 2050. Central range – illustrative net zero consistent scenarios in CB6 Impact Assessment. Full range – based on whole range from UK Hydrogen Strategy. Source: BEIS, 2021. Contains public sector information licensed under the Open Government Licence v3.0.

The British Energy Security Strategy, published in April 2022, set out a doubling of the UK’s 2030 hydrogen production ambitions from 5GW to 10GW (BEIS, 2022b). At least half of this is to be met by green hydrogen (generated by electrolysis using energy from low carbon power generation) whilst the remainder of the 10GW is likely to be met by blue hydrogen (generated from natural gas with carbon capture and storage). For the purposes of this report, it is assumed that in 2030 half of the 10GW production ambition is from electrolysis (5GW) and the other half is from blue hydrogen and other technologies (5GW), although the exact mix is dependent on a range of factors.

The government's aim is to have up to 1GW of electrolytic hydrogen and up to 1GW of carbon capture and storage (CCS)-enabled hydrogen operational or in construction by 2025. As of April 2022, the UK hydrogen project pipeline was around 20GW, including an estimated 14GW of potential electrolytic hydrogen. This is based on potential deployment according to project developers, and does not directly relate to funding decisions on individual projects or volume support through specific funding allocation windows (DIT, 2022) (Figure 2). The UK's goals to develop a hydrogen economy to supply industry with clean fuel will require investment for the development of a range of hydrogen production technologies. This report will explore the material requirements of planned developments, with a particular focus on critical raw material usage.

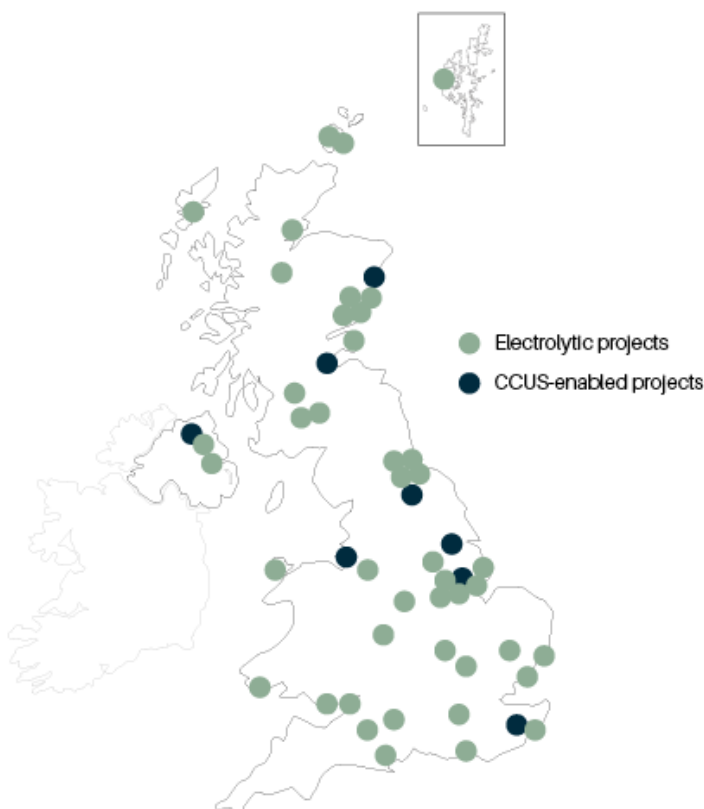

Figure 2. UK hydrogen projects. Source: DIT, 2022. Contains public sector information licensed under the Open Government Licence v3.0.

2 Hydrogen production

Industrial-scale quantities of hydrogen can be produced using either steam methane reforming (SMR) or electrolysis. Steam methane reforming is the process in which methane from natural gas is heated with steam and a catalyst, to produce hydrogen and carbon dioxide. SMR is a well-established technology and is currently the most widely used process for the generation of hydrogen, commonly referred to as 'grey' hydrogen. Grey hydrogen is cheapest way to produce hydrogen (as low as \$1/kg depending on the price of natural gas), but the associated greenhouse gas emissions are high – 11.1-13.7 kg of CO₂ for every 1 kg of hydrogen (Howarth and Jacobson, 2021).

The emissions from SMR can be reduced by capturing and storing the carbon dioxide in an underground geological reservoir, where it is isolated from the atmosphere (BGS, 2021). This is known as Carbon Capture and Storage (CCS). Hydrogen produced by steam methane reforming with CCS is referred to as 'blue' hydrogen. Blue hydrogen costs slightly more than grey hydrogen and captures approximately 90% of emissions (Howarth and Jacobson, 2021), although the types of projects that the UK is likely to support will use more efficient technologies, such as Autothermal Reforming (ATR), with anticipated capture rates of 95% and above.

2.1 ELECTROLYSIS

Electrolysis is the process of using electricity to split water into hydrogen and oxygen in an electrolyser. Depending on the energy source, hydrogen produced via electrolysis can be referred to as either 'green' (renewable energy) or 'pink' (nuclear energy), while grid electrolysis is only as low carbon as the input electricity. Zero-carbon sources represented 48.5% of the UK's energy mix in 2022, compared to 40% from gas and coal power stations (National Grid, 2023), and is expected to be largely decarbonised by the early 2030s.

There are four main electrolysis technologies: alkaline, proton exchange membrane (PEM), alkaline exchange membrane (AEM) and solid oxide electrolysis (Figure 3, Table 1). They all use the same chemistry but are differentiated by the electrolyte materials and the temperature

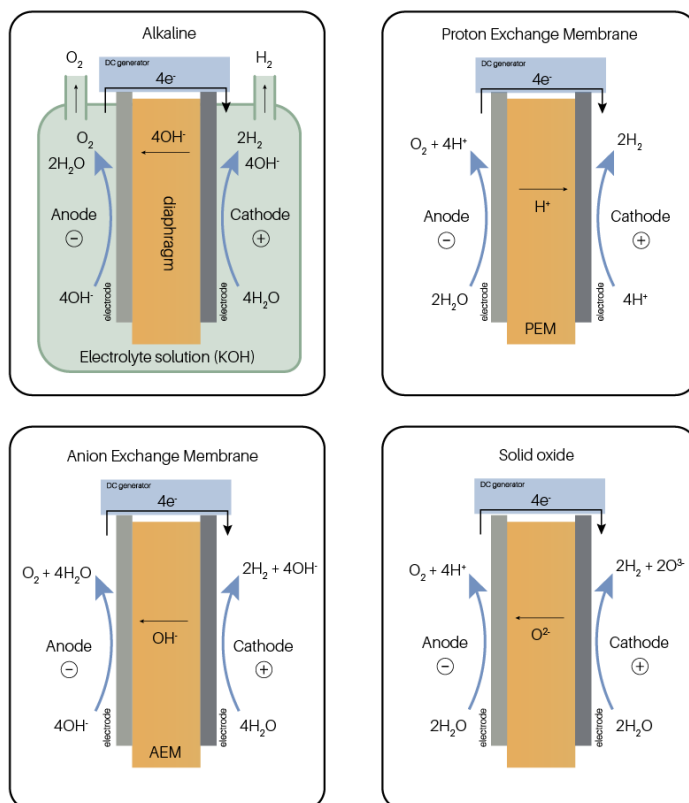

Figure 3. Different types of electrolysis technologies. Source: IRENA, 2020

at which they operate.

Alkaline and proton exchange membrane (PEM) electrolysis are widely available commercially, while solid oxide and anion exchange membrane (AEM) electrolysis are less mature, with only a few companies and original equipment manufacturers (OEMs) involved in their manufacture.

Alkaline electrolysis is the most mature form of electrolysis, with a history of deployment in the chlor-alkali industry. In alkaline electrolysis the reaction that separates the water into hydrogen and oxygen occurs in a solution composed of water and a liquid electrolyte (usually potassium hydroxide solution), between nickel-coated stainless-steel electrodes and a zirconium dioxide (ZrO_2) based diaphragm (IRENA, 2020). The electrical conversion efficiency of alkaline electrolysis at the higher heating value (HHV) of hydrogen is currently around 77%, but forecast to increase to 82% for plants coming online in 2050 (BEIS, 2021). Alkaline electrolysis can ramp up (and down) hydrogen production quicker than SMR plants, allowing greater flexibility. However, when compared to other electrolyser technologies, such as PEM, it is slower to respond to fluctuating power supply, so it is less suited to renewable energy sources.

PEM electrolysis splits water by using an ionically conductive perfluorosulfonic acid (PFSA) membrane and electrodes. The acidic environment facilitated by the PFSA membrane, high voltages, and oxygen evolution at the anode creates a harsh oxidative environment, demanding the use of materials that can withstand these conditions. Titanium-based materials, platinum-group metal (PGM) catalysts and protective coatings are necessary to provide long-term stability and optimal cell efficiency (IRENA, 2020). PEM has an assumed efficiency (HHV) of 72%, which is forecast to increase to 82% by 2050 (BEIS, 2021). PEM electrolysis has a fast ramp-up and turn-down hydrogen production capability, making it ideally suited to fluctuations typical of renewable power generation or the provision of rapid response to the grid.

The focus for development of alkaline electrolysers is to improve the dynamic response and capability for intermittent operation, while for PEM it is to operate at a larger scale with higher efficiency and lower cost.

Solid oxide electrolysis splits water using a solid oxide, or ceramic (yttria-stabilized zirconia), electrolyte. They operate at higher temperatures (700-850°C) than PEM or alkaline, enabling favourable kinetics using relatively cheap nickel electrodes. The thermo-chemical cycling leads to faster degradation and shorter lifetimes (2-3 years, compared to 10 years and 20 years for PEM and alkaline, respectively) (Nechache and Hody, 2021). Solid oxide electrolysers are currently only deployed at the kW-scale, although some current demonstration projects have reached 1 MW (BEIS, 2021).

Anion exchange membrane (AEM) electrolysis is a relatively nascent technology, with limited deployment to date. AEM's potential lies in the combination of a less harsh environment (compared to alkaline) with the efficiency of PEM. This allows for the use of non-precious metal catalysts and titanium-free components. Further development is needed to resolve chemical and mechanical stability problems with the AEM membrane (Zignani et al., 2022).

All four electrolyser technologies have challenges, ranging from use of critical raw materials to performance and durability. There is no outright winner, and future use is likely to depend on the application to which each is allocated.

	Alkaline	PEM	Solid oxide	AEM
Operating temperature	70-90°C	50-80°C	700-850°C	40-60°C
Operating pressure	1-30 bar	< 70 bar	1 bar	< 35 bar
Electrolyte	Potassium hydroxide (KOH) 5-7 mol L ⁻¹	PFSA membranes	Yttria-stabilized zirconia (YSZ)	DVB polymer support with KOH or NaHCO ₃ 1 mol L ⁻¹
Separator	ZrO₂ stabilized with PPS mesh	Solid electrolyte (above)	Solid electrolyte (above)	Solid electrolyte (above)
Electrode/catalyst (oxygen side)	Nickel coated perforated stainless steel	Iridium oxide	Perovskite-type (e.g., LSCF, LSM)	High surface area nickel or NiFeCo alloys
Electrode/catalyst (hydrogen side)	Nickel coated perforated stainless steel	Platinum nanoparticles on carbon black	Nickel/YSZ	High surface area nickel
Porous transport layer anode	Nickel mesh (not always present)	Platinum -coated sintered porous titanium	Coarse nickel -mesh or foam	Nickel foam
Porous transport layer cathode	Nickel mesh	Sintered porous titanium or carbon cloth	None	Nickel foam or carbon cloth
Bipolar plate anode	Nickel -coated stainless steel	Platinum -coated titanium	None	Nickel -coated stainless steel
Bipolar plate cathode	Nickel -coated stainless steel	Gold-coated titanium	Cobalt -coated stainless steel	Nickel -coated stainless steel
Frames and sealing	PSU, PTFE, EPDM	PTFE, PSU, ETFE	Ceramic glass	PTFE, silicon

Table 1. Electrolyser technologies compared. Critical raw materials, as identified in the UK Criticality Assessment (Lusty et al., 2021), are highlighted in red. © 2020 IRENA.

2.2 ELECTROLYSER INSTALLATIONS

In 2021 alkaline electrolyzers accounted for almost 70% of global installations, followed by PEM with a 25% market share (IEA, 2022a). AEM and solid oxide make up the remaining share of installed capacity today. For projects planned to come online after 2025 developers have not yet announced the electrolyser type. The share of alkaline electrolysis in the total installed capacity (for which technology information is available) is forecast to remain at around 60% for the next five years, as it is easier to scale production quickly. By 2030, the share of PEM is expected to have increased to around 50%, as improving economies of scale reduce costs (IEA, 2022a).

In contrast to global projections, PEM is expected to make up a greater share of the UK market sooner – 70% by 2030 – owing to its inherent flexibility advantages associated with renewable power generation, which the UK has high ambitions to achieve. For this reason, this study will focus specifically on the material requirements for PEM, principally platinum and iridium and the wider platinum-group metal group. Nonetheless, it is acknowledged that the exact split of hydrogen production methods, or indeed the scale of demand, are still largely unknown.

Assuming 70% of the UK's green hydrogen production could be met by PEM electrolysis by 2030, in line with ambitions set out in the British Energy Security Strategy, this could see a minimum of 3.5GW of PEM capacity and 1.5GW of alkaline capacity installed by the end of the decade. However, with 14GW of potential electrolytic hydrogen identified in the UK pipeline (DIT, 2022), a 70% contribution from PEM equates to almost 10GW (Figure 4).

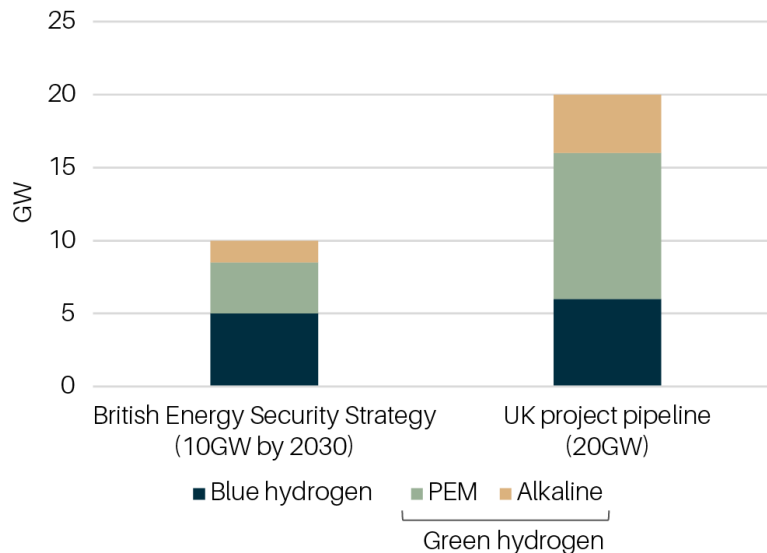

Figure 4. Estimated share of green hydrogen electrolyser technologies. Note: The UK project pipeline is estimated at 20GW (April 2022) based on plans and proposals for projects that are in the public domain. More projects are under development in all parts of the UK. Source: BEIS, 2022b and DIT, 2022. Contains public sector information licensed under the Open Government Licence v3.0.

2.3 ELECTROLYSERS AND CRITICAL MINERALS

Critical materials are an important consideration for all four electrolyser technologies (see red text in table 1). For the purpose of this study, particular attention will be paid to PEM and alkaline electrolysers as the most mature and commercially available technologies on the market currently.

For PEM, the electrode coating at the anode needs to be highly resistant to corrosion while supporting sufficient electrochemical activity, and iridium is one of the very few metals that meets these criteria. The porous transport layer (PTL) requires significant amounts of titanium-based materials coated with platinum. Platinum is also used for the cathode, although tantalum could be a promising alternative. Iridium and platinum are commonly referred to as platinum-group metals (PGMs). Current metal loading requirements for PEM are in the region of 0.1-0.3 kg/MW platinum and 0.4-0.7 kg/MW iridium, which represents about 4% of the entire system cost of a PEM electrolyser (Figure 5). While titanium components also contribute to the high costs of PEM, this is mostly related to the expense of component manufacturing, and less related to the cost of raw materials (IRENA, 2020).

Nickel is the primary material used to resist the highly caustic environment in alkaline electrolysis, although some designs derived from the chlor-alkali industry also include platinum and cobalt. For existing nickel-based alkaline technologies, loadings are around 800 kg/MW nickel, 10,000 kg/MW steel and 500 kg/MW aluminium (IEA, 2022b). Despite the high volume, nickel also accounts for around 4% of the overall cost of an alkaline electrolyser (Figure 6) (IRENA, 2020).

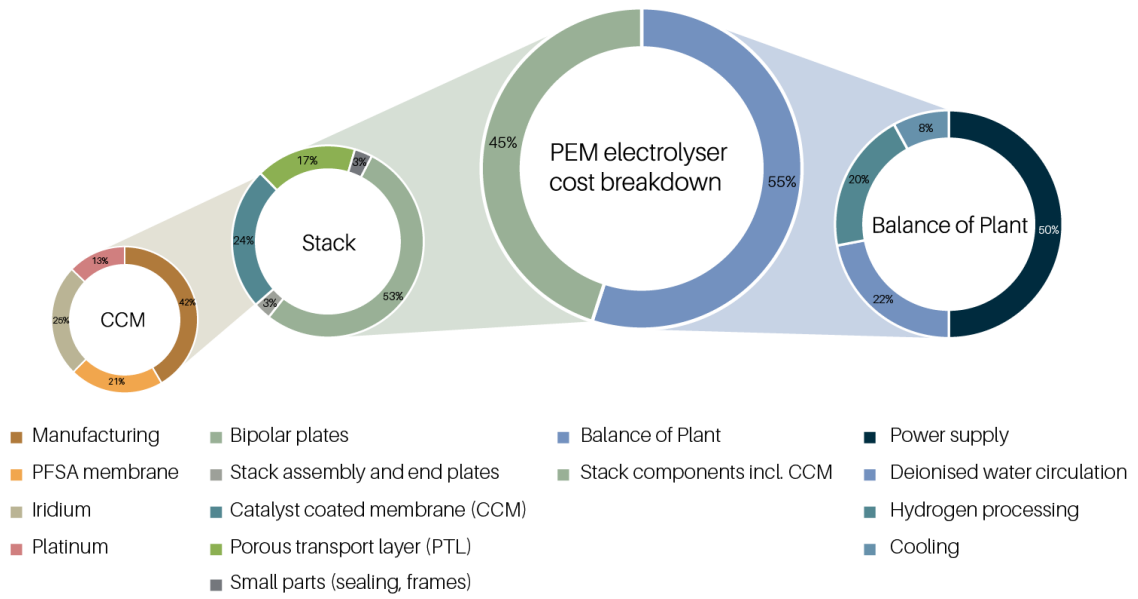

Figure 6. Cost breakdown for a 1 MW PEM electrolyser. Note: The specific breakdown varies by manufacturer, application and location, but values in the figure represent an average. Balance of Plant refers to the supporting components and auxiliary systems. © 2020 IRENA.

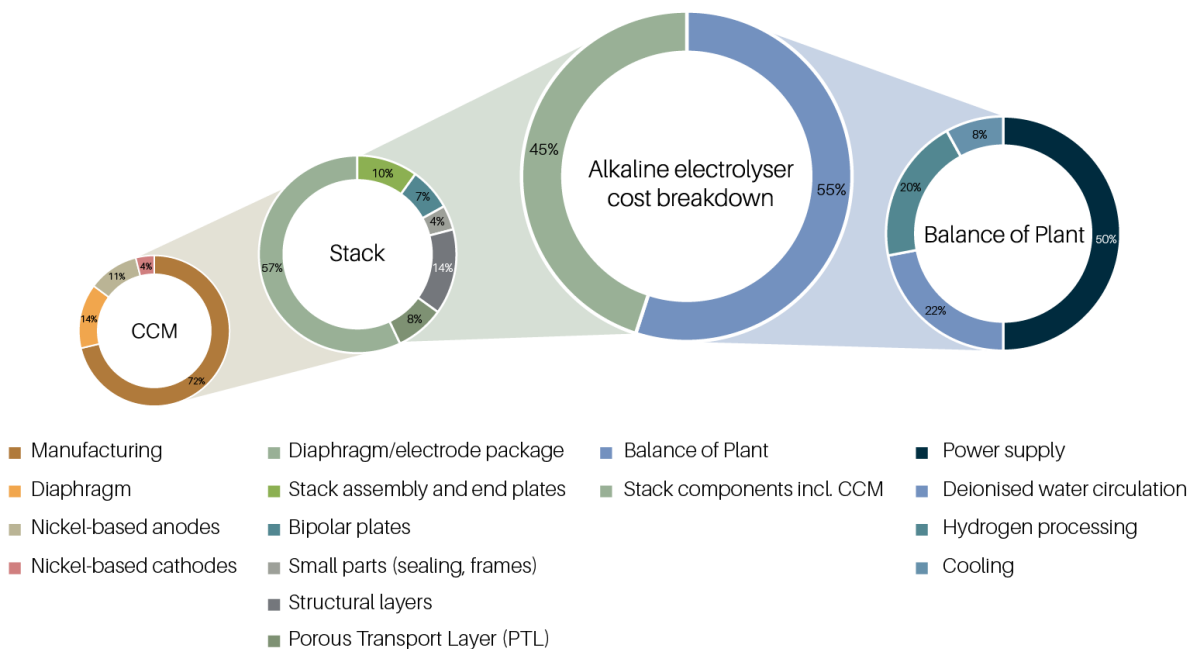

Figure 5. Cost breakdown for a 1 MW alkaline electrolyser. Note: The specific breakdown varies by manufacturer, application, and location, but values in the figure represent an average. Balance of Plant refers to the supporting components and auxiliary systems. © 2020 IRENA.

Materials of concern for solid oxide electrolyzers are yttrium, zirconium and nickel. The key requirements for a solid electrolyte is that it has good ionic conduction to minimize cell impedance, is electrically insulating to prevent electronic conduction, and sufficiently dense to avoid gas transport between the two electrode atmospheres (Nechache and Hody, 2021). Yttria-stabilized zirconia (YSZ) is the most common electrolyte material used owing to high ionic conductivity associated with good thermal and chemical stabilities. The hydrogen electrode is typically composed of nickel-YSZ, while the oxygen electrode currently relies on perovskite-based materials such as lanthanum strontium cobalt ferrite (LSCM). Current metal loadings for solid oxide electrolyzers are 150-200 kg/MW nickel, ~40 kg/MW zirconium, ~20 kg/MW lanthanum and <5 kg/MW yttrium (IEA, 2022b).

Nickel is the primary catalyst material used in anion exchange membrane (AEM) electrolyzers, but there is very little information available in the public domain regarding current loadings. There are very few commercially viable options for AEM; it is still generally considered to be at a prototype stage (Figure 7), although the technology is rapidly evolving.

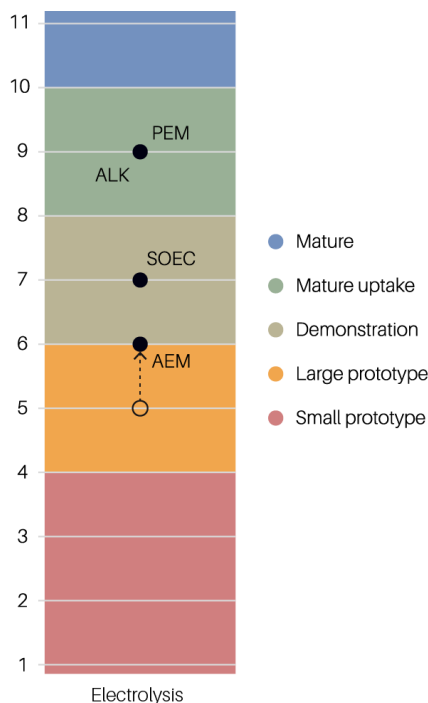

Figure 7. Electrolyser technology readiness. Source: IEA (2022b), modified by BGS.

Despite their perceived expense, PGMs are not considered to be a limiting economic factor for PEM electrolyzers, with platinum and iridium currently representing around the same proportion of cost as nickel in alkaline electrolyzers. The main challenge to ensure PEM's long-term viability, as well as supporting the sustainable growth of the hydrogen sector as a whole, is addressing the potential supply-demand imbalance for iridium. Significant research and development is underway to reduce the amount of iridium required per gigawatt of installed capacity, by thrifting (using less metal) and improving electrolyser efficiencies, whilst also improving recycling systems to optimise reuse and recovery (Johnson Matthey, 2022).

The innovation required to reduce the intensity of iridium use is based on existing approaches in material engineering, such as increasing the catalyst surface area and using thinner layers of catalyst coating material. Metal fabricators and OEMs have had high success rates using these methods over many years to reduce loadings of expensive metals while simultaneously

increasing the performance of their products – reducing platinum and palladium loadings in autocatalysts being a prime example. The Kopernikus Power-2-X Research Network in Germany has developed a catalyst with 10 times lower iridium loadings (Federal Ministry of Education and Research, 2020), while a partnership between technology group, Heraeus Precious Metals and mining company, Sibanye-Stillwater is looking at the substitution of iridium with other metals such as ruthenium, as well as developing alternative metal oxide structures (Heraeus, 2022).

Ruthenium is a much larger market than iridium (almost four times more production each year) and is the third most abundant PGM after platinum and palladium. Although it is recognised as a 'watchlist' mineral in the UK Critical Minerals Strategy (meaning it has potentially increasing criticality) (BEIS, 2022c), ruthenium has far fewer competing demands than other viable substitutes, such as nickel and other base metals, and is therefore being seriously considered by industry as a suitable long-term alternative.

Based on current industry average loadings of 0.2 kg/MW platinum and 0.55 kg/MW iridium, the assumed 3.5GW of PEM capacity installed in the UK by 2030 equates to around 700 kg platinum and 1925 kg iridium. Using the UK's project pipeline (DIT, 2022), which could include up to 10GW of PEM capacity, metal demand is equivalent to 2000 kg platinum and 5500 kg iridium.

At current loadings, UK demand for platinum and iridium in PEM electrolyzers by 2030 in the 3.5GW scenario would be equivalent to 0.05% and 4% of cumulative global production (mined + recycled), respectively. In the 10GW scenario, this increases to 0.13% for platinum and 11% for iridium. However, this assumes that loadings remain unchanged, and therefore cumulative quantities – for iridium in particular – are expected to be lower than these calculated figures. It is important to note that there are substantial platinum stocks that could meet increased demand from the hydrogen sector (Johnson Matthey, 2023).

3 Hydrogen applications

3.1 FUEL CELLS

A fuel cell's technology is essentially the inverse of an electrolyser; generating electricity through the electrochemical reaction of hydrogen and oxygen (Figure 8). At the anode site of a fuel cell, a catalyst splits dihydrogen into electrons and H^+ protons. The protons then pass through a porous electrolyte membrane driven by the oxidative potential of free oxygen from the air, while the electrons are forced through a circuit, generating an electric current. At the cathode, protons, electrons and oxygen combine to produce the fuel cell's only by-product: water and heat.

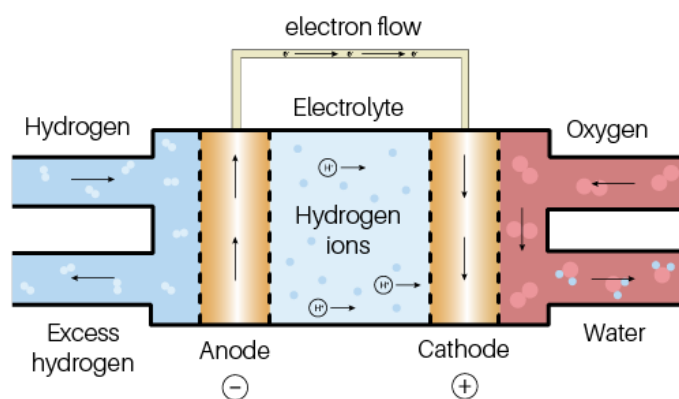

Figure 8. Schematic diagram of a fuel cell. BGS © UKRI

Platinum is used in hydrogen fuel cells that generate electricity for fuel cell electric vehicles (FCEVs), and combined with ruthenium for stationary power applications. Fuel cells offer higher efficiencies than conventional technologies, such as the internal combustion engine (ICE). They operate quietly and have a modular construction that is easily scalable, making them suitable for a range of potential applications, including combined heat and power (CHP), distributed power generation, and transport.

Fuel cells are particularly well-suited to vehicle segments with high power and energy demands, such as heavy-duty trucks, while battery-electric vehicles (BEVs) are likely to become mainstream in light vehicle use cases, such as passenger cars. Manufacturers and OEMs recognise that BEVs and FCEVs are not competing technologies, but rather have distinct applications that contribute to the same objective of global decarbonisation.

There are several types of fuel cells, differentiated by the type of electrolyte separating the fuel from the oxygen. This classification determines the kind of electrochemical reactions that take place in the cell, the required catalysts, the operating temperature and the required fuel (Figure 9).

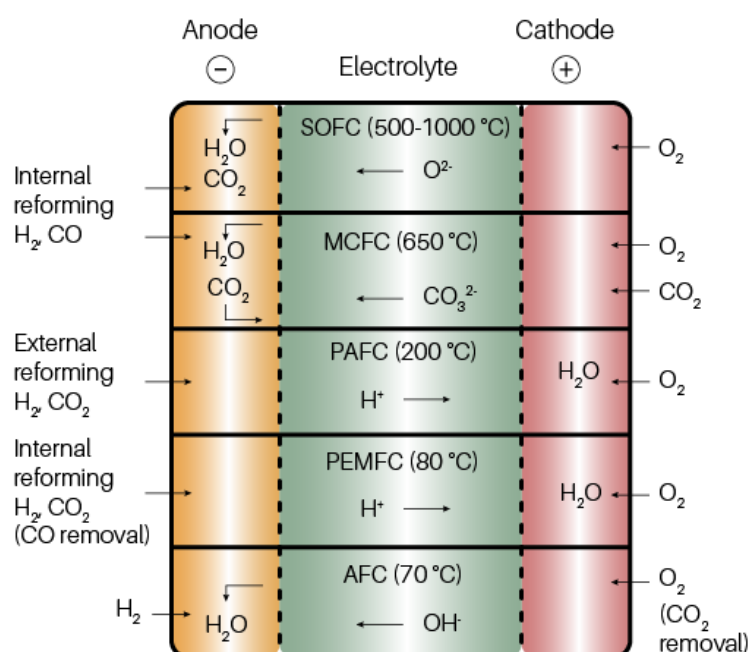

Figure 9. Summary of fuel cell types. SOFC – solid oxide fuel cells, MCFC – molten carbonate fuel cell, PAFC – phosphoric acid fuel cell, PEMFC – proton exchange membrane fuel cell, AFC – alkaline fuel cell. BGS © UKRI.

Proton exchange membrane (PEM) fuel cells have been used successfully for many years in a variety of medium power applications owing to their efficiency and relatively low operating temperature range. PEM fuel cells are of particular interest to the automotive industry as they have a high power density, are lighter and more compact than other fuel cells. PEM fuel cells across all mobility uses accounted for 86% of the total 2.3GW of fuel cells shipped globally in 2021 (E4tech, 2022).

3.2 FUEL CELLS AND CRITICAL MINERALS

As with electrolyzers, critical mineral availability is a consideration for PEM fuel cells more than any other fuel cell technology, although the dominance of PEM in the fuel cell market means it is naturally subject to increased scrutiny. Current metal loadings for PEM fuel cells are around 0.5 g/kW platinum. Cerium and iridium are used in very small volumes, while ruthenium is used

in some stationary applications; exact loadings are unknown. Innovation to reduce the intensity of PGM use has already shown promising results. For example, In 2014 Toyota's first-generation Mirai FCEV used around 40 g of platinum, a 75% reduction in platinum per kW of output compared to the 2008 prototype (James et al., 2018). The second generation Mirai released in 2020 reduced this further by a third per kW while increasing the maximum power output from 114 kWh to 158 kWh. Plans are in place in Japan to reach 5 g per car in 2040. Similar targets for reduced platinum loading per kW have also been set by US Department of Energy (DOE), including specific targets for heavy-duty vehicles which require three times more power than cars (IEA, 2022b). As well as technological innovation, the increasing purity of hydrogen generated by electrolysis, rather than by SMR of petrochemically derived hydrogen, is expected to reduce the need for ruthenium in stationary applications (Heraeus, 2021).

Transport is expected to represent a crucial early market for hydrogen in the UK, driving some of the earliest low carbon production and rollout of infrastructure to ensure that the hydrogen economy develops at a sufficient pace to enable a FCEV market to develop. APC forecast the demand for fuel cells in the UK will be around 10GW by 2030 and 14GW by 2035, the equivalent to 140 000 vehicles (Advanced Propulsion Centre, 2022). At current loadings this equates to around 7000 kg platinum by 2035, equivalent to around 0.27% of cumulative platinum supply over the next 12 years (assuming steady state of supply).

4 Platinum-group metal demand

While FCEVs and the wider transport sector are expected to become a significant component of the hydrogen economy in the future, internal combustion engine (ICE) vehicles currently leads demand for platinum, palladium and rhodium.

The usefulness of PGMs is determined by their unique and specific shared chemical and physical properties. While certain of these properties are shared by other materials, it is the particular combination of their chemical and physical properties that make the PGMs so valuable in their end-markets. PGMs have high and specific catalytic activity, possess high thermal resistance, are chemically inert and biocompatible, as well as being hard but malleable for forming into shapes. Platinum, palladium and rhodium are used in higher-volume industrial and medical applications, while iridium and ruthenium have niche high-technology applications.

4.1 PLATINUM

Autocatalysts represent around 43% of global platinum demand, at 91 440 kg in 2022 (SFA (Oxford), 2023) (Figure 10). Platinum is an effective catalyst for the conversion of hydrocarbons and carbon monoxide to harmless compounds, particularly in diesel engines for both light- and heavy-duty vehicles. As autocatalyst systems have become increasingly sophisticated in response to ever-tightening emissions legislation globally and the advent of on-road (rather than laboratory) testing, metal loadings have increased in recent years. Following the 2015 'Dieselgate' scandal in Europe, the increased focus on reducing nitrogen oxides (NO_x) from diesel vehicles resulted in higher urea dosing rates and more platinum per catalyst. The public perception of diesel cars since the scandal has resulted in a significant drop in demand, and the share of diesel cars in the EU has shrunk from 45.8% in 2016 to just 16.4% in 2022 (ACEA, 2023). Despite higher platinum loadings per vehicle, the net result for metal demand has been a decline.

Platinum-based catalysts are also key to many large-scale industrial chemical processes, including nitric acid and silicone production and crude oil synthesis, which collectively accounted for 25 690 kg in 2022 (12% of total demand). Platinum tooling is also used in glass fabrication (18 320 kg), while its biocompatibility makes it well suited to a variety of medical and dental procedures, as well as in the pharmaceutical industry for use in various cancer treatments. Jewellery is another significant market for platinum, particularly in China owing to specific demographic and cultural factors. Jewellery represented 24% of total platinum demand

in 2022 at 51 320 kg. The global hydrogen sector accounted for just 1% of total platinum demand in 2022 with an estimated 2740 kg (SFA (Oxford), 2023).

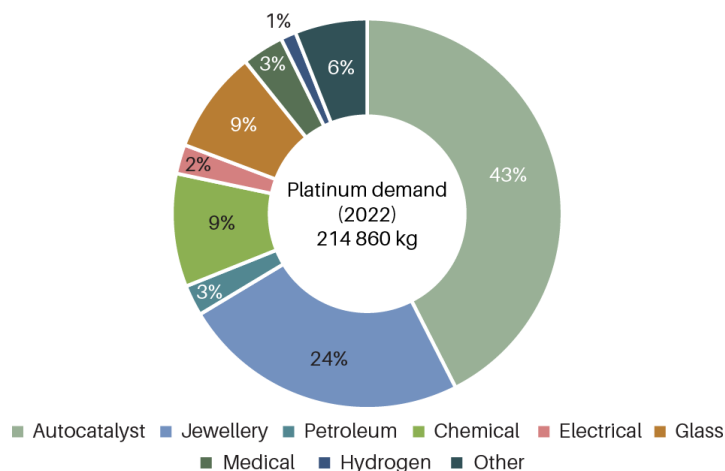

Figure 10. Global platinum demand by sector 2022. Demand data © SFA (Oxford) 2023, used with permission.

4.2 IRIDIUM

Iridium has several niche industrial applications, with demand led by the electrochemical sector, primarily the chloralkali process, at 2800 kg and 34% of total demand in 2022 (Figure 11). The electrical sector accounted for 2280 kg in 2022, or 27% of total demand. This includes the use of iridium crucibles for growing materials for light-emitting diodes (LED) for lighting, and surface acoustic wave (SAW) filters for mobile phones. Iridium tips also improve the performance of automotive spark plugs to improve the efficiency of the combustion process in gasoline engines, which represents around 630 kg annually (8% of total demand). Chemical applications, including the manufacture of acetic acid, a key intermediate in the manufacture of other bulk chemicals, account for around ~500 kg. It is also used as a minor alloying component with platinum in medical devices (~500 kg) and jewellery (~200 kg). The hydrogen sector currently accounts for around 5% of global demand at just over 450 kg in 2022 (SFA (Oxford), 2023).

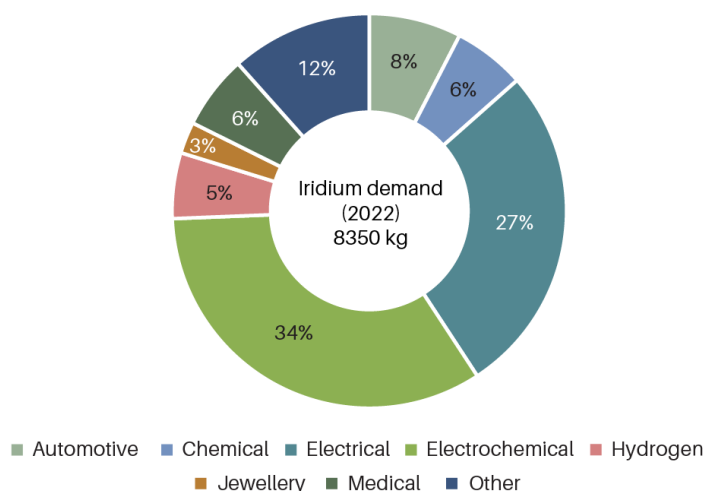

Figure 11. Global iridium demand by sector 2022. Demand data © SFA (Oxford) 2023, used with permission.

4.3 RUTHENIUM

Ruthenium shares many of its applications with iridium, where they are used together in several of the industrial chemical applications mentioned previously. Another important catalyst market for ruthenium is the manufacturing of ammonia, driven by the need for nitrogen fertilizers for food production. The chemical sector accounted for almost a third of total demand for iridium (29%) in 2022 at 8380 kg. (Figure 12). Electrical applications represent a further 33% of iridium demand, including hard disk drives (HDD), chip resistors and numerous semiconductor components which enable increasing miniaturisation and efficiency in various electronic devices. Ruthenium's role in the hydrogen sector, coupled with platinum in stationary PEM fuel cells, accounted for around 1890 kg in 2021 or 7% of total demand (SFA (Oxford), 2023).

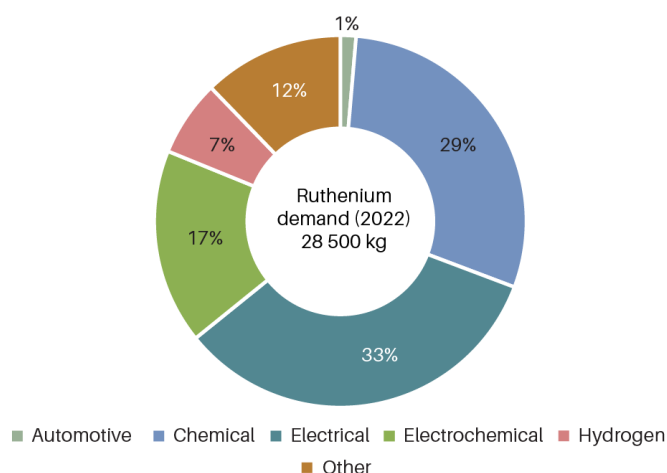

Figure 12. Global ruthenium demand by sector 2022. Demand data © SFA (Oxford) 2023, used with permission.

5 Platinum-group metal supply

Platinum and iridium are two of the six platinum-group metals (PGMs), which also includes palladium, rhodium, ruthenium and osmium. Together with gold and silver, PGMs are often referred to as precious or noble metals.

PGMs tend to occur, in varying proportions, together in the same geological deposits. In most cases, platinum is the primary commodity and the remaining PGMs are considered by-products. Since these by-products, or minor metals, are often contributing only a small fraction to producers' revenues, the usual market mechanisms of supply and demand do not apply. While increasing demand for minor metals will almost certainly lead to higher prices, typically mining companies will not produce any more for risk of eroding the major metal's price. However, rhodium and palladium have increasingly driven producers' revenue streams in recent years, which have more than offset any impact on the platinum price from a platinum surplus.

Nevertheless, the supply of minor by-product PGMs (particularly iridium) are relatively inelastic, and even a significant price increase could usually not compensate the negative impact on total revenues when there is oversupply of platinum.

Depending on the composition of the ore that is extracted, platinum can be classed as either the primary or secondary metal produced. In South Africa and Zimbabwe, platinum is mined as a primary metal, whereas in Russia platinum is produced as a by-product of nickel. In North America, platinum is produced as a by-product of palladium.

5.1 MINE SUPPLY

Around 173 700 kg of platinum was mined worldwide last year, with 73% of annual platinum production coming from South Africa (Figure 13) (SFA (Oxford), 2023). The balance comes from Russia (12%), Zimbabwe (9%) and North America (4%). Other minor producers, including China, Colombia and Finland, produce the remaining 2%. The mine supply of minor PGMs, which includes iridium, ruthenium and rhodium, osmium, is highly concentrated in South Africa with an ~85% share of the global market. Global mine production of iridium was around 8 400 kg in 2022. South Africa accounted for 82% of this production, with minor contributions from Russia (9%) and Zimbabwe (7%). Ruthenium has the highest supply concentration out of all of the PGMs, with 91% of global mine production in 2021 (26 900 kg) attributed to South Africa. Zimbabwe and Russia make up the remaining market share, at 4% respectively (SFA (Oxford), 2023).

There are currently no sanctions on PGMs from Russia, nor its largest producer, Nor Nickel. However, two of Russia's government-owned PGM refineries have been removed from London Platinum and Palladium Markets' (LPPM) Good Delivery list, meaning they are no longer able to sell platinum or palladium in the London/Zurich bullion market. If further restrictions were enforced, short-term disruption and an associated price rally could be expected, but it is unlikely that sanctions would prevent refined material from leaving the country entirely as exports to China would likely still be possible (Clarke, 2022).

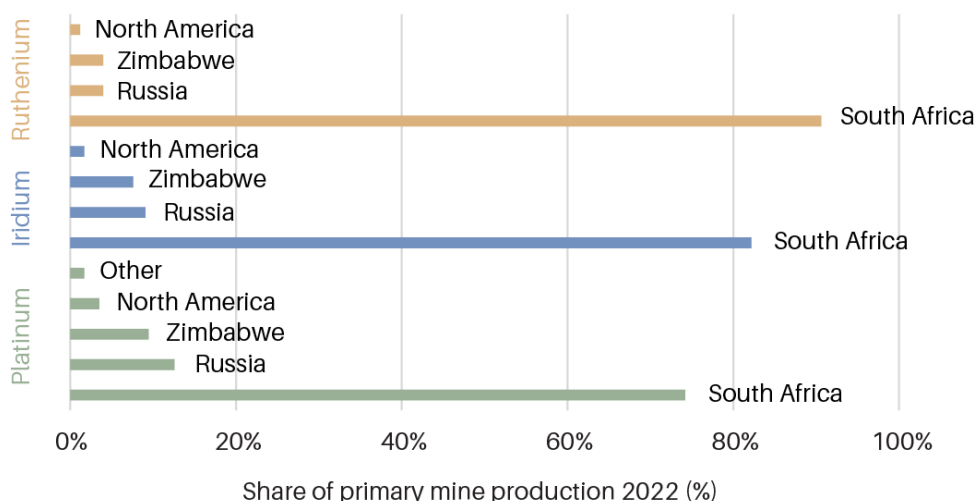

Figure 13. Share of primary platinum, iridium and ruthenium production 2022. Production data © SFA (Oxford) 2023, used with permission.

5.2 RECYCLING

The durability of PGMs, combined with their recent high prices, has driven a high recycling rate wherever possible. The technology required to extract PGMs from spent and redundant products, whilst complex, is well defined and sufficient capacity exists around the world. However, the rising proportion of silicon carbide (SiC) diesel particulate filters from diesel systems (platinum-rich) are more difficult to process than petrol autocatalysts, with only a limited number of smelters able to process them in volume (Techemet, 2022).

There are two basic forms of PGM recycling: closed loop and open loop. Generally, closed loop recycling takes place with industrial users (such as glass fabrication and oil refining). The material remains under ownership of the user, and is continually recycled and reused in the same application with very transparent flows, ensuring high rates of recycling. In contrast, open loop recycling typically applies to consumer items, such as electronics and autocatalysts, where recycled and refined material is sold back into the market, but with no guarantee that it will be recycled when the products in which they are used reach the end of their lives. However, there is generally a strong economic case for recovery given the high technical recyclability of PGMs.

In some applications such as medical devices, spark plugs and HDDs, where PGMs are present in such small quantities, collection rates are typically the limiting factor for recovery owing to the costs associated with dismantling. For these applications, the precious metals contained are effectively lost to the recycling chain. Owing to their purity, the recycling rates for jewellery and physical investment items (bars, coins) are very high.

Platinum from secondary sources (i.e. open loop recycling) was equivalent to 22% of total supply in 2022, at around 48 000 kg (SFA (Oxford), 2023). Recovery was likely to have been incentivised by high PGM (and steel, in the case of end of life vehicles) prices during 2021 and 2022, which encouraged the backlog of end-of-life scrap that had accumulated during 2020 to move through the value chain. By contrast, open-loop recycling accounts for a very small proportion of iridium and ruthenium supply each year, especially given the low historical prices for these metals. However, they are routinely recycled in a closed loop regime for industrial consumers, which significantly reduces the amount of primary material these industries require (Johnson Matthey, 2022).

Analysis by The World Bank and Hydrogen Council has shown that out of 14 raw materials required for a hydrogen economy, the smallest share of primary material required relative to overall hydrogen demand is for platinum (followed closely by cerium and titanium) owing to a high recovery rate both in the sector, and for the material generally (Figure 14). By comparison, the study showed that materials such as niobium have much higher shares of primary material due to lower recovery rates and return to the open market, which makes primary sourcing of these materials particularly important (World Bank, 2022).

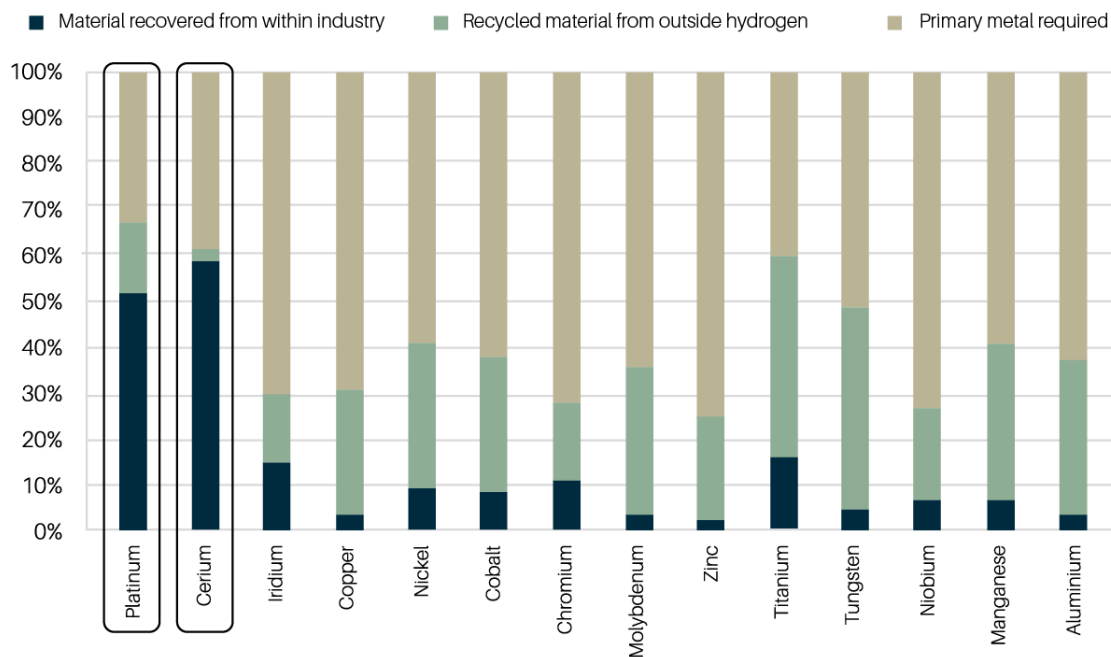

Figure 14. Share of demanded material by source for materials for hydrogen. Note: vanadium and graphite were excluded due to lack of data on recycling rates. © 2022 The World Bank Group.

With increased collection and recycling rates, improved recovery from waste products and a wider shift towards a circular economy, the requirement for primary material is expected to reduce significantly. If higher rates of recovery are realised for platinum in the hydrogen sector (to 99% of available material) the requirement for primary platinum falls by 18%. Greater recycled content of platinum from other demand sectors (from 33% to 50%) reduces the primary requirement by 25%. If both rates increase i.e. improved recovery across all end-use sectors, primary demand is forecast to fall by 39% (World Bank, 2022).

5.2.1 Recycling in the UK

The UK has a well-established PGM recycling industry, with large secondary refiners including Johnson Matthey, Techemet and Umicore operating at various stages throughout the value chain. Notably, at its refining sites in Royston, Hertfordshire and Brimsdown, Enfield, Johnson Matthey is one of only a few companies in the world with the facilities to recycle five PGM including iridium and ruthenium.

6 Platinum-group metal reserves and resources

South Africa's Bushveld Complex dominates global PGM reserves, with its three ore bodies – Merensky, UG2 and Platreef – accounting for around 70 000 tonnes of combined PGMs (USGS, 2022). This represents around 90% of global PGM reserves. There are also considerable reserves in other countries, notably the Great Dyke in Zimbabwe (1197 tonnes), the Stillwater Complex in the US (899 tonnes), and in nickel-copper deposits such as the Norilsk-Talnakh district of Russia (4498 tonnes) and the Sudbury area of Canada (311 tonnes) (USGS, 2022). True availability is almost certainly greater (Cawthorn, 2010), as companies often only report reserves that are required to satisfy their short- and medium-term plans. Reserves are a dynamic entity that measures what is available to exploit today under present market conditions and with current technology. They are just a small part of a mineral resource, which is a natural concentration of minerals that are of potential economic interest for future extraction. Reserves are not static and are never actually depleted; rather they are continually replenished by exploration which converts resources to reserves. They are not reliable indicators of future mineral availability and do not reflect all that exists in the Earth's crust.

6.1 UK PLATINUM-GROUP METAL RESOURCE POTENTIAL

With increased global interest in strategic metals, the British Geological Survey (BGS) undertook systematic reconnaissance exploration for PGMs over several prospective areas in the UK between 1985 and 1989. The main targets investigated were layered mafic-ultramafic intrusions of Caledonian age in north-east Scotland, including some areas previously investigated for nickel; Caledonian alkaline intrusions in north-west Scotland; and ophiolite complexes in Shetland, Cornwall and south-west Scotland (BGS, 2020).

Research identified high concentrations of PGMs and nickel, and the occurrence of a wide range of nickel and PGM-bearing minerals, in several areas of the UK. However, in many cases these metals are minor constituents of polymetallic ores and are unlikely to constitute anything more than a minor by-product of the extraction of another metal.

The most attractive targets for nickel exploration, with possible by-products PGM and cobalt, are located in the Caledonian layered mafic-ultramafic intrusions in north-east Scotland. Aberdeen Minerals Limited is a privately-owned company engaged in mineral exploration for nickel, copper, cobalt and PGMs in this region (Aberdeen Minerals, 2022). There is potential for the occurrence of PGM mineralisation in Northern Ireland associated with the Antrim Lava Group. However, there are no estimates of resources of PGMs anywhere in the UK (BGS, 2020).

7 Trade of platinum-group metals

Platinum is traded in many forms, generally in either unwrought (ores, concentrates, powders) or in manufactured or semi-manufactured forms (e.g., ingots, wire, mesh). Platinum trade is complex as significant quantities of mattes are processed in countries other than those in which they have been produced. For example, many nickel-copper mattes from Canada are processed in the UK and Norway. Imports of platinum are dominated by leading industrialised nations. These include the US (168 118 kg), Japan (127 421 kg), the UK (124 531) and Germany (115 988 kg) in 2022 (Figure 15) (DESA/UNSD, 2023). In the UK, PGMs are refined at Johnson Matthey, which is the largest secondary refiner of PGMs in the world (Johnson Matthey, 2023). It has refineries in Royston, Hertfordshire and Brimsdown, Enfield. There are several other small refineries that mostly process high-value secondary scrap items.

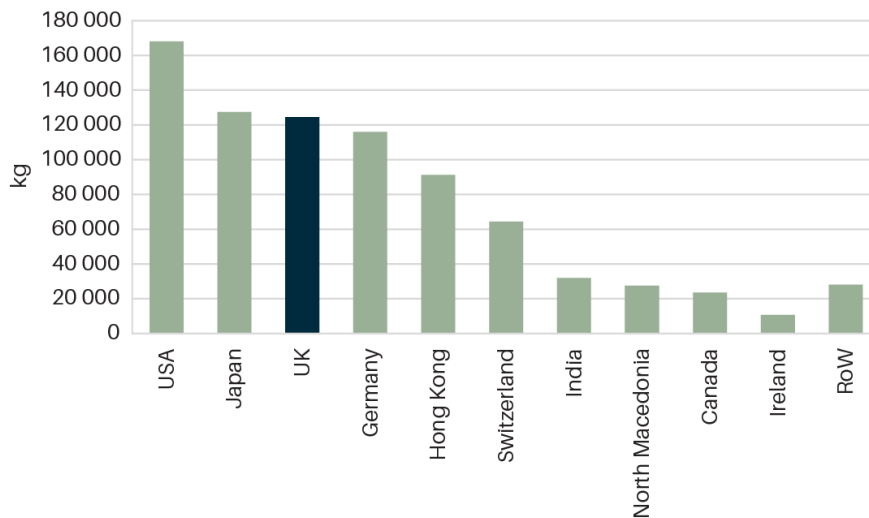

Figure 15. Imports of platinum (HS 7110). RoW = Rest of World. Source: DESA/UNSD, 2023 (United Nations Comtrade database).

Iridium and ruthenium are also traded in either unwrought or semi-manufactured forms, although the supply chain complexities that exists for platinum are even greater for minor metals. There are very few companies in the world that have the technological capacity to process iridium and ruthenium, largely a result of the same properties that recommend their use (high melting temperature, strength at high temperatures and oxidation resistance). With such a high proportion of total demand accounted for by the chemical and electrical sectors, imports of iridium and ruthenium are dominated by chemical producers and tech manufacturing nations such as Japan (11 700 kg in 2022) and Hong Kong (7881 kg in 2022) The UK imported 2340 kg of iridium, ruthenium and osmium in 2022 (Figure 16) (DESA/UNSD, 2023).

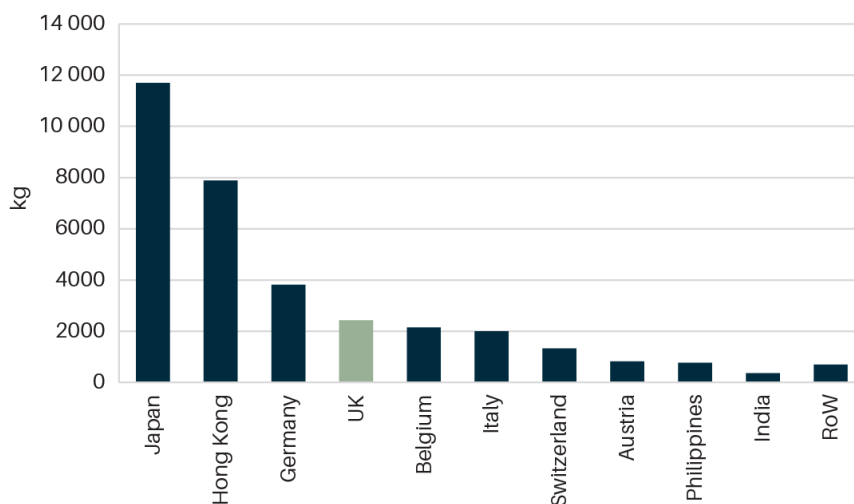

Figure 16. Imports of iridium, ruthenium and osmium (HS 711041). RoW = Rest of World. Source: DESA/UNSD, 2023 (United Nations Comtrade database).

Owing to an established track record of PGMs in many diverse applications in the UK, plus a long history of refining and recycling, the supply chain challenges that often exist for materials

used in nascent demand sectors, such as batteries, are much less of a consideration for PGMs in the context of hydrogen. The UK has good bilateral relations with several key producing regions, such as South Africa and Canada, and in November 2022 announced the creation of a new Partnership on Minerals for Future Clean Energy Technologies with South Africa. The partnership will utilise the UK's expertise as the home of leading global mining houses and financial services centre for metals, and South Africa as the leading producer of PGMs, to promote increased responsible exploration, production and processing of minerals in South Africa (BEIS, 2022d).

8 Other considerations

In addition to the material content for producing hydrogen and consuming technologies, such as fuel cells, the material requirement of associated infrastructure and renewable energy technologies is a major consideration. Indeed, analysis from The World Bank and Hydrogen Council has shown that the greatest global demand for materials by volume comes from the renewable energy infrastructure needed to power electrolyzers (assuming a scenario of 50% onshore wind and 50% solar photovoltaic). Green hydrogen via electrolysis is projected to account for 67% of total global hydrogen production by 2050, which translates to around 85 million tonnes of aluminium, 20 million tonnes of zinc and 5 million tonnes of copper to support the required rollout of wind and solar PV capacity (World Bank, 2022) (Figure 17).

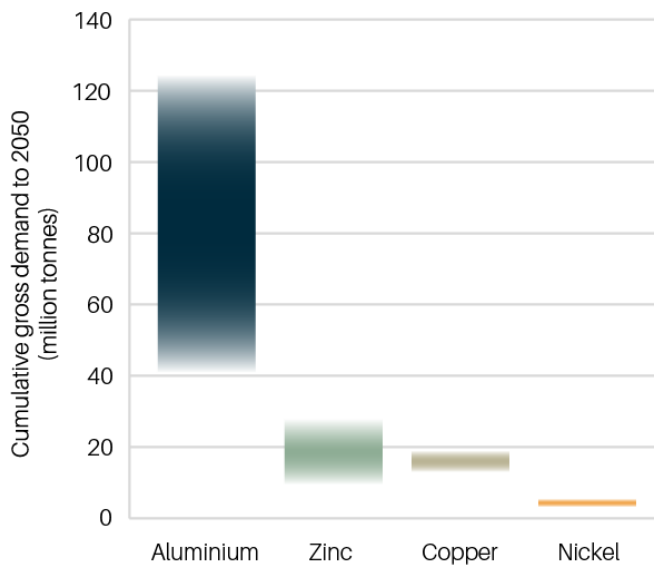

Figure 17. Cumulative gross demand up to 2050 for aluminium, zinc, copper and nickel from renewable technologies associated with the hydrogen sector. © 2022 The World Bank Group.

8.1 TRANSPORTATION, DISTRIBUTION AND STORAGE

The transportation, distribution and storage of low carbon hydrogen must also be taken into account from a material demand point of view. For distribution, there is likely to be both the use of existing natural gas pipelines and also new hydrogen pipeline networks. Natural gas pipelines may need reinforcing and retrofitting to take high concentrations of hydrogen, although the

material implications of this are expected to be relatively low. The construction of new pipeline networks is likely to have a much higher material footprint, namely steel. The European Hydrogen Backbone initiative have proposed that a future hydrogen pipeline network totalling 39,700 km and spanning 21 countries would consist of 69% existing gas network and 31% new pipeline (European Hydrogen Backbone, 2022). The latter is estimated to account for approximately 20 million tonnes of steel by 2040, equal to around 1% of current annual global steel production (World Bank, 2022).

In the UK, National Grid are exploring the development of a hydrogen network that would join industrial clusters around the country, potentially spanning up to 2000 km. The initial feasibility indicates that around 25% of existing pipeline could be repurposed, carrying at least a quarter of the UK's current demand for gas (National Grid, 2022). A high level calculation indicates that the remaining 1500 km of new pipeline would require around 2.4 million tonnes of steel, equivalent to 34% of current UK annual steel production (Hutton, 2021). The Government is aiming to reach a policy decision in 2023 on whether to allow blending of up to 20% hydrogen by volume into the gas distribution networks. It is currently building the necessary evidence base to determine whether blending meets the required safety standards, is feasible, and represents value for money. Further studies and research is ongoing to consider the safety of 100% hydrogen in the gas grid.

For hydrogen storage, the main material implications are likely to arise from the demand for specialist tanks, either within vehicles or to complement other large storage solutions such as salt caverns. The main material implication is likely to be related to use of steel and other elements that it is required to be alloyed with. These are already widely used in the chemicals industry and at hydrogen refuelling stations.

9 Summary

The growth of a UK hydrogen economy will see a sharp increase in electrolyser demand, with the British Energy Security Strategy identifying an ambition of 5GW of green hydrogen capacity by 2030, and around 14GW already in the project pipeline. PEM electrolysis is assumed to account for 70% of the UK's green hydrogen production. Depending on the 'top-down' (i.e. policy) or 'bottom-up' (i.e. project pipeline/order books) approach used to modelling, this is estimated to equate to 700-2000 kg platinum and 1925-5500 kg iridium. However, this represents a significant – and unsustainable, at current metal loadings – increase in demand for these materials, which are highly geographically concentrated in South Africa. This creates risks of supply constraints and price volatility in case of geopolitical events or disruption to logistics.

These material challenges are not exclusive to PEM technology, and will require collaboration across industry and government. Technological development is needed to reduce the quantity of materials (thriftiness) or find less critical alternatives (substitution). For materials which cannot be replaced with alternatives, recycling is expected to become an increasingly vital supply stream. This is particularly important for iridium, which is a small, illiquid market with very little input from open-loop recycling. Strategic partnerships with key producing nations are expected to become increasingly prevalent with countries seeking to secure and diversify future supply, and improve the resilience of critical minerals supply chains.

References

British Geological Survey holds most of the references listed below, and copies may be obtained via the library service subject to copyright legislation (contact libuser@bgs.ac.uk for details). The library catalogue is available at: <https://of-ukrinerc.olib.oclc.org/folio/>.

Aberdeen Minerals, 2022. Securing Scotland's Electric Future. Available at: <https://aberdeenminerals.com/>.

ACEA, 2023. Fuel types of new cars: battery electric 12.1%, hybrid 22.6% and petrol 36.4% market share full-year 2022. Available at: <https://www.acea.auto/fuel-pc/fuel-types-of-new-cars-battery-electric-12-1-hybrid-22-6-and-petrol-36-4-market-share-full-year-2022/>.

Advanced Propulsion Centre, 2022. Johnson Matthey announcement could lead to UK dominance in fuel cells. Available at: <https://www.apcuk.co.uk/johnson-matthey-announcement-could-lead-to-uk-dominance-in-fuel-cells/#:~:text=Johnson%20Matthey%20announcement%20could%20lead%20to%20UK%20dominance,for%20the%20production%20of%20hydrogen%20fuel%20cell%20components.>

BEIS, 2021. UK Hydrogen Strategy.

BEIS, 2022a. United Kingdom of Great Britain and Northern Ireland's Nationally Determined Contribution.

BEIS, 2022b. British Energy Security Strategy.

BEIS, 2022c. Resilience for the Future: The United Kingdom's Critical Minerals Strategy.

BEIS, 2022d. UK and South Africa working in partnership on minerals for future clean energy technologies. Available at: <https://www.gov.uk/government/publications/uk-south-africa-joint-statement-on-partnering-on-minerals-for-future-clean-energy-technologies/uk-and-south-africa-working-in-partnership-on-minerals-for-future-clean-energy-technologies.>

BGS, 2020. The potential for platinum-group metals and nickel in the UK. British Geological Survey.

Cawthorn RG, 2010. The platinum group element deposits of the Bushveld Complex in South Africa. *Platinum Metals Review* 54, pp205-215.

Clarke B, 2022. Sanctions on Russia could impact PGM supply significantly. SFA (Oxford). Available at: <https://www.sfa-oxford.com/market-news-and-insights/sfa-initial-analysis-of-the-impact-on-pgms-from-russia-ukraine-action/>.

DESA/UNSD, 2023. UN Comtrade Database.

DIT, 2022. Hydrogen Investor Roadmap: Leading the Way to Net Zero.

E4tech, 2022. Fuel Cell Industry Review 2021.

European Hydrogen Backbone, 2022. European Hydrogen Backbone: A European Hydrogen Infrastructure Vision Covering 28 Countries.

Federal Ministry of Education and Research, 2020. How the Kopernikus project P2X converts renewable electricity into plastics and fuels, gases and heat. Available at: <https://www.kopernikus-projekte.de/en/projects/p2x>.

Heraeus, 2021. Use of ruthenium in fuel cells set to turn down as green hydrogen trend turns up. In: Mining Weekly. Available at: https://www.miningweekly.com/article/use-of-ruthenium-in-fuel-cells-set-to-turn-down-as-green-hydrogen-trend-turns-up-heraeus-2021-05-04/rep_id:3650.

Heraeus, 2022. Sibanye-Stillwater and Heraeus enter into a Partnership to develop and commercialise Novel Electrolyser Catalysts for the Production of Green Hydrogen. Available at: https://www.heraeus.com/en/hpm/company/hpm_news/2022_hpm_news/sibanye_stillwater_and_heraeus_enter_into_a_partnership.html.

Howarth RW, Jacobson MZ, 2021. How green is blue hydrogen? *Energy Science & Engineering* 9, pp1676-1687.

Hutton G, 2021. UK steel industry: statistics and policy. House of Commons Library.

IEA, 2022a. Global Hydrogen Review 2022.

IEA, 2022b. The Role of Critical Minerals in Clean Energy Transitions.

IRENA, 2020. Green Hydrogen Cost Reduction: Scaling Up Electrolysers to Meet the 1.5°C Climate Goal.

James BD, Huya-Kouadio JM, Houchins C, DeSantis DA, 2018. Mass Production Cost Estimation of Direct H₂ PEM Fuel Cell Systems for Transportation Applications: 2018 Update.

Johnson Matthey, 2022. Recycling and thrifting: the answer to the iridium question in electrolyser growth. Available at: <https://matthey.com/en/iridium-supply-hydrogen-electrolysers>.

Johnson Matthey, 2023. PGM Market Report May 2023.

Lusty PAJ, Shaw RA, Gunn AG, Iodine NE, 2021. UK criticality assessment of technology critical minerals and metals.

National Grid, 2022. Project Union Launch Report.

National Grid, 2023. Breaking records: The UK's renewable energy in numbers. Available at: <https://www.nationalgrid.com/stories/energy-explained/how-much-uks-energy-renewable>.

Nechache A, Hody S, 2021. Alternative and innovation solid oxide electrolysis cell materials: A short review. *Renewable and Sustainable Energy Reviews*, 149, p. 111322.

SFA (Oxford), 2023. PGM supply and demand data 2022.

Techemet, 2022. PGM recycling in the UK.

UNFCCC, 2022. Sharm el-Sheikh Implementation Plan.

USGS, 2022. Mineral Commodity Summaries 2022: Platinum-group metals. pp126-127.

World Bank, 2022. Sufficiency, sustainability, and circularity of critical materials for clean hydrogen.