



**National
Oceanography Centre**
NATURAL ENVIRONMENT RESEARCH COUNCIL

National Oceanography Centre

Cruise Report No. 46

RRS *Discovery* Cruise DY077

14 APR - 01 MAY 2017

Cruise to the Porcupine Abyssal Plain
sustained observatory

Principal Scientist
R S Lampitt

2017

National Oceanography Centre, Southampton
University of Southampton Waterfront Campus
European Way
Southampton
Hants SO14 3ZH
UK

Tel: +44 (0)23 8059 6347
Email: R.Lampitt@noc.ac.uk

DOCUMENT DATA SHEET

<i>AUTHOR</i> LAMPITT, R S et al	<i>PUBLICATION</i> <i>DATE</i> 2017
<i>TITLE</i> RRS <i>Discovery</i> Cruise DY077, 14 Apr - 01 May 2017. Cruise to the Porcupine Abyssal Plain sustained observatory.	
<i>REFERENCE</i> Southampton, UK: National Oceanography Centre, Southampton, 193pp. (National Oceanography Centre Cruise Report, No. 46)	
<i>ABSTRACT</i> <p>The Discovery slipped moorings in Southampton at 0830h GMT on Friday 14th April 2017 after an uneventful mobilisation apart from the discovery that on opening one of the sealed boxes of mooring rope for the PAP#1 mooring, it was found to be empty. Discovery arrived at PAP at 2005h for our first station, a CTD rosette cast to 100m. The Discovery left the site at 1645h on Friday 28th April, somewhat earlier than expected due to a predicted storm which did indeed cause some difficulties for the ship during the return to the UK coming alongside at Portland at 1100h on Monday 1st May to exchange personnel and equipment. Moorings were slipped at 0800h on 2nd May followed by equipment trials and a final docking at Southampton NOC at 2000h on 2nd May.</p> <p>The Porcupine Abyssal Plain Observatory is a sustained, multidisciplinary observatory in the North Atlantic coordinated by the National Oceanography Centre, Southampton. For over 20 years the observatory has provided key time-series datasets for analysing the effect of climate change on the open ocean and deep-sea ecosystems.</p> <p>More information on PAP can be found in NOCs website at: http://projects.noc.ac.uk/pap/ where the most current data can be found: http://projects.noc.ac.uk/pap/pap-april-2017 PAP is one of the 23 fixed-point open ocean observatories included in the Europe-funded project FixO3, coordinated by Professor Richard Lampitt at NOC: http://www.fixo3.eu/</p> <p>This 4-year project started in September 2013 with the aim to integrate the open ocean observatories operated by European organizations and is a collaboration of 29 partners from 10 different countries.</p>	
<i>KEYWORDS</i>	
<i>ISSUING ORGANISATION</i> National Oceanography Centre University of Southampton Waterfront Campus European Way Southampton SO14 3ZH UK Tel: +44(0)23 80596116 Email: nol@noc.soton.ac.uk <i>A pdf of this report is available for download at: http://eprints.soton.ac.uk</i>	

This page intentionally left blank

Contents

1	Scientific Personnel	9
2	Ships Personnel.....	10
3	Itinerary.....	11
4	Background.....	11
	IT and data management.....	13
4.1	Cruise overview.....	13
4.2	Ship Scientific Computing Systems.....	13
4.3	Position and Attitude.....	14
4.4	Meteorology and Sea Surface Monitoring Package.....	14
4.5	Kongsberg EA640 10 & 12kHz Single Beam EchoSunder.....	15
4.6	Kongsberg EM122 and EM710 MultiBeam Echo Sounders.....	16
4.7	Sound Velocity Profiles.....	16
4.8	75kHz & 150kHz Hull Mounted ADCP Systems.....	16
4.9	Gravity Meter.....	16
4.10	WAMOS Wave Radar.....	16
4.11	CTD, LADCP, Salinometer & Moorings.....	16
4.12	Sound Velocity Profile Details.....	16
5	Moorings Operations.....	17
5.1	PAP#1.....	17
5.1.1	PAP#1 Recovery.....	17
5.1.2	PAP#1 Deployment.....	18
5.2	PAP#3.....	19
5.2.1	PAP#3 Deployment.....	19
5.2.2	PAP#3 Position.....	20
5.3	Other Moorings Operations.....	20
6	Ocean Engineering Group Technical Report.....	25
6.1	Romica General Purpose Winch (PAP).....	25
6.2	Romica Multi-Purpose Winch.....	26
6.3	Lebus 5 Ton Winch (Port Fit).....	26
6.4	Liquid Nitrogen Generator (Orange Frame).....	27
6.5	Mega Core System.....	27
6.6	Milli Q Integral 15 System.....	27
6.7	RN Laboratory Container.....	27
7	NMF Sensors and Moorings CTD.....	28
7.1	Introduction and over view:.....	28
7.1.1	Summary of CTD casts.....	30
7.1.2	List of sensors.....	31
7.1.3	Detail of transmissometer calculation of coefficients.....	33
7.1.4	CTD processing overview.....	34
7.1.5	Summary of processing of CTD casts.....	35
8	PAP#1 Observatory Report.....	36
8.1	General Description.....	36
9	Deployed Observatory Description.....	37

9.1	Design modifications of the new observatory.....	37
9.1.1	Data Hub and Telemetry units.....	37
9.1.2	PAP0003 Software and Hardware Updates.....	40
9.2	Deployment and initial performance.....	42
10	Deployed PAP#1 Sensors.....	44
10.1	Aanderaa Seaguard s/n1614.....	44
10.1.1	Pre-deployment calibration of Seaguard.....	44
10.1.2	Seaguard and ZebraTech.....	48
10.2	SUNA Nitrate Sensor (S/N: 745).....	49
10.3	WETLabs Fluorometer.....	49
10.4	Sea-Bird SBE 37 MicroCATs.....	51
10.5	Pro-Oceanus dissolved gas sensors.....	52
10.5.1	CO2 sensor on the buoy.....	52
10.5.2	CO2 sensor on the frame.....	53
10.5.3	GTD sensor on the frame.....	54
10.6	pH SensLab sensors.....	54
10.7	SeaFET pH sensors.....	55
10.7.1	Deployment of SeaFETs on the sensor frame and the buoy.....	55
10.8	Cycle Phosphate Sensor 164 for Deployment.....	57
10.9	Satlantic OCR-507 Irradiance sensors.....	58
11	PAP#1 Recovered Data Hub and Telemetry Systems.....	59
11.1	Recovery of the Seaguard (s/n1130).....	61
11.2	Pro-Oceanus Sensors.....	63
11.3	Sea-Bird SBE 37 MicroCATs.....	64
11.4	Satlantic OCR-507 Irradiance sensors.....	64
11.5	WETLabs Fluorometer.....	64
11.6	Cycle Phosphate Sensor 177 recovered.....	66
11.7	Satlantic SUNA Nitrate Sensor (S/N 745).....	68
11.7.1	Pre-deployment calibration.....	68
11.7.2	Deployment on the sensor frame.....	69
11.7.3	SUNA (S/N 698) recovery.....	69
11.8	Satlantic SeaFETs pH sensors.....	71
11.8.1	Pre-deployment calibrations for deployment on a sensor frame and buoy.....	71
11.8.2	Deployment on the buoy and sensor frame.....	71
11.9	SeaFET recovery and calibration.....	73
11.10	Star ODDIs Recovery and Deployment at PAP#1.....	76
11.10.1	Recovery and calibration.....	76
11.10.2	Pre-deployment calibration on a CTD frame.....	80
11.10.3	Deployment on a buoy and sensor frame.....	82
12	Sensor Calibration.....	84
12.1	CTD sampling.....	84
12.2	CTD chlorophyll calibration.....	86
12.3	Oxygen analysis on-board.....	88
13	Underway Sampling and CO ₂ Measurements.....	93
14	Sediment Trap Mooring PAP#3 - Science.....	95
15	Composition and Function of Dissolved Organic Matter.....	98
16	Zooplankton Net Sampling.....	102

17	Microplastics.....	104
17.1	Microplastics in the water column	104
17.2	Microplastics in the sediment.....	105
17.3	Microplastics and bacteria.....	106
18	Molecular Ecology.....	111
19	PELAGRA Cam, HoloCam, In-situ Camera, and Marine Snow Catcher	118
19.1	PELAGRA Cam.....	118
19.2	The Red Camera Frame (RCF)	119
19.3	The In-Situ camera	120
19.4	Marine Snow Catcher.....	121
19.5	PELAGRA Cam and gel traps on the PELAGRAS.....	125
20	BioOptical Platform.....	125
21	PELAGRA	130
21.1	Ballast trial deployment	131
21.2	Deployment 1	132
21.3	Deployment 2	137
22	Upper Ocean Sediment Trap and Carbon Flux Measurement Method Intercomparison	142
22.1	WHOI Neutrally Buoyant Sediment Traps (NBSTs).....	144
22.2	WHOI Surface Tethered Trap (STT) arrays	145
22.2.1	Trap sample processing.....	146
22.2.2	Thorium-234	146
22.2.3	In situ pumps.....	148
23	FixO ³ -TNA project LO ³ CAted	149
23.1	PAP#3 mooring deployment	150
23.2	PAP#3 mooring recovery	151
23.3	Bathysnap	155
23.4	Future work	156
24	Benthic Studies	157
24.1	Moorings	159
24.2	Bathysnap.....	159
24.2.1	Set-up steps	159
24.2.2	Camera set-up	159
24.2.3	Amphipod trap	163
24.3	Megacoror.....	164
24.3.1	Lab processing	164
24.5	Otter trawl	171
24.5.1	Body measurement of trawl-caught benthic specimen	177
25	Appendix 1: CTD Configuration Files	178
26	Station List.....	191



1 Scientific Personnel

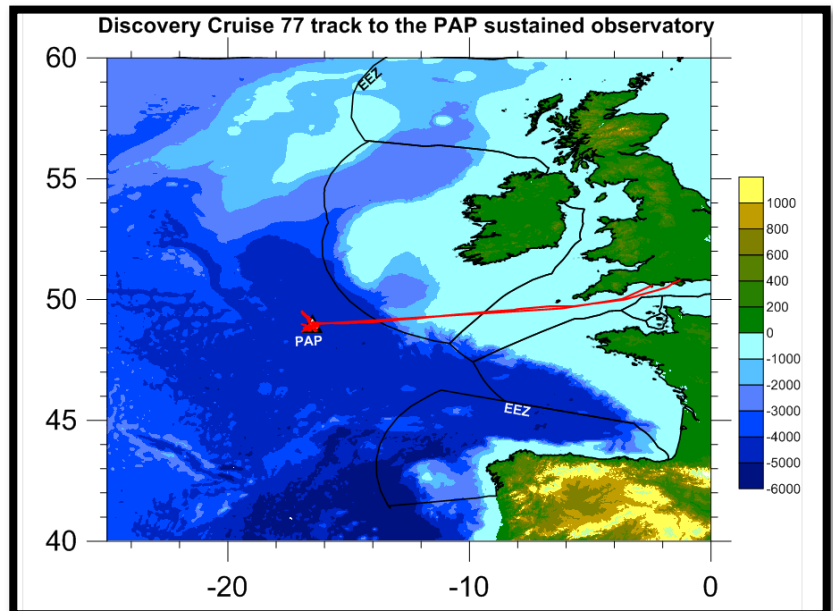
No.	Family Name	Given Names	Rank or Rating
1	LAMPITT	RICHARD STEPHEN	PI
2	HARTMAN	SUSAN ELIZABETH	Scientist
3	BETT	BRIAN JAMES	Scientist
4	BAKER	CHELSEY ADRIANNE	Scientist
5	CHARCOS LLORENS	MIGUEL VICENTE	Scientist
6	PABORTSAVA	KATSIARYNA	Scientist
7	PEBODY	CORINNE ANNE	Scientist
8	YOUNG III	CURTIS ROBERT	Scientist
9	BENOIST	NOELIE MARIE ALINE	Scientist
10	BROWN	ROBIN JAMES	Scientist
11	GATES	ANDREW RUSSELL	Scientist
12	IVERSEN	MORTEN HVITFELDT	Scientist
13	KONRAD	CHRISTIAN	Scientist
14	LAGUIONIE MARCHAIS	CLAIRE	Scientist
15	NEALOVA	LENKA	Scientist
16	SAW	KEVIN ANTONY	Scientist
17	BUESSELER	KENNETH Owen	Scientist
18	ESTAPA	MARGARET LOUISE	Scientist
19	EVANS	CLAIRE	Scientist
20	GENIO	LUCIANA DE MELO SANTOS	Scientist
21	KENYON	JENNIFER ANN	Scientist
22	MILLIKEN	NEIL PAUL	Scientist
23	PIKE	STEVEN MAURICE	Scientist
24	SONG	JESSICA	Scientist
25	WHITTLE	STEPHEN PAUL	Tech
26	RUNDLE	NICHOLAS JAN	Tech
27	BURRIS	JAMES EDWARD	Tech
28	SHEPHERD	OWAIN	Tech
29	SYMES	LISA JANE	SST

2 Ships Personnel

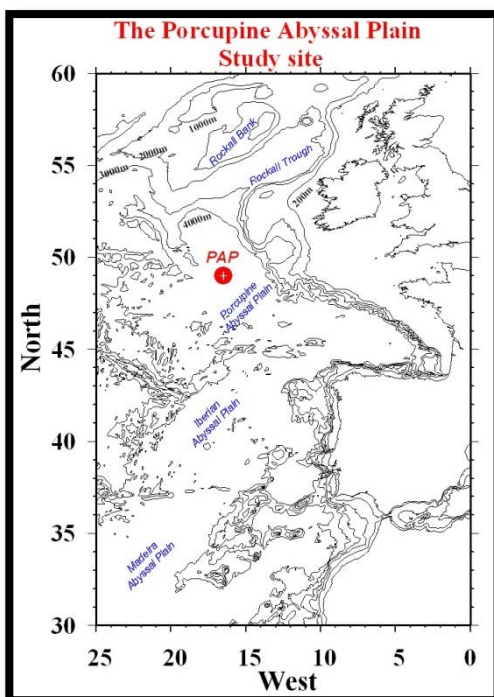
No.	Family Name	Given Names	Rank or Rating
1	COX	JOANNA LOUISE	Master
2	MAHON	ANDREW	C/O
3	MORROW	DECLAN DANIEL ANDERSON	2/O
4	NORRISH	NICHOLAS JOHN	3/O
5	BILLS	JAMES	C/E
6	O'SULLIVAN	GERALDINE ANNE	2/E
7	SILAJDZIC	EDIN	3/E
8	MURREN	MICHAEL GERARD	3/E
9	WYTHE	VIVIAN MICHAEL	D/E
10	BROOKS	FELIX ROBERT ARTHUR	ETO
11	WATTERSON	IAN CHARLES	PCO
12	SMITH	STEPHEN JOHN	CPOS
13	MacLEAN	ANDREW	CPOD
14	SPENCER	ROBERT GEORGE	POD
15	McLENNAN	WILLIAM	SG1A
16	LAPSLEY	CRAIG JAMES	SG1A
17	HOPLEY	JOHN MICHAEL	SG1A
18	SQUIBB	MARK	SG1A
19	LAWES	DUNCAN ANDREW	ERPO
20	ASHFIELD	MARK JAMES	H/Chef
21	WHALEN	AMY KERRY	Chef
22	ORSBORN	JEFFREY ALAN	Stwd
23	BRACKENRIDGE	CHRISTOPHER	A/Stwd

3 Itinerary

The *Discovery* slipped moorings in Southampton at 0830h GMT on Friday 14th April 2017 after an uneventful mobilisation apart from the discovery that on opening one of the sealed boxes of mooring rope for the PAP#1 mooring, it was found to be empty. *Discovery* arrived at PAP at 2005h for our first station, a CTD rosette cast to 100m. The *Discovery* left the site at 1645h on Friday 28th April, somewhat earlier than expected due to a predicted storm which did indeed cause some difficulties for the ship during the return to the UK coming alongside at Portland at 1100h on Monday 1st May to exchange personnel and equipment. Moorings slipped at 0800h on 2nd May followed by equipment trials and a final docking at Southampton NOC at 2000h on 2nd May.



4 Background

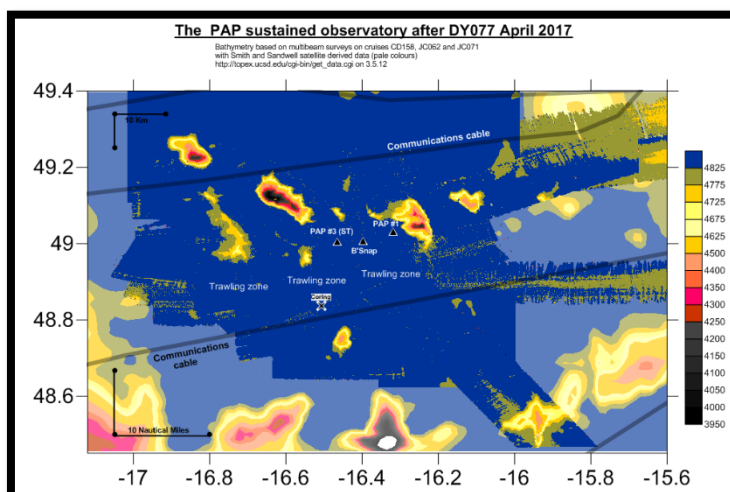


The Porcupine Abyssal Plain Observatory is a sustained, multidisciplinary observatory in the North Atlantic coordinated by the National Oceanography Centre, Southampton. For over 20 years the observatory has provided key time-series datasets for analysing the effect of climate change on the open ocean and deep-sea ecosystems.

More information on PAP can be found in NOC's website at: <http://projects.noc.ac.uk/pap/> where the most current data can be found: <http://projects.noc.ac.uk/pap/pap-april-2017>

PAP is one of the 23 fixed-point open ocean observatories included in the Europe-funded project FixO3, coordinated by Professor Richard Lampitt at NOC: <http://www.fixo3.eu/>

This 4-year project started in September 2013 with the aim to integrate the open ocean observatories operated by European organizations and is a collaboration of 29 partners from 10 different countries.



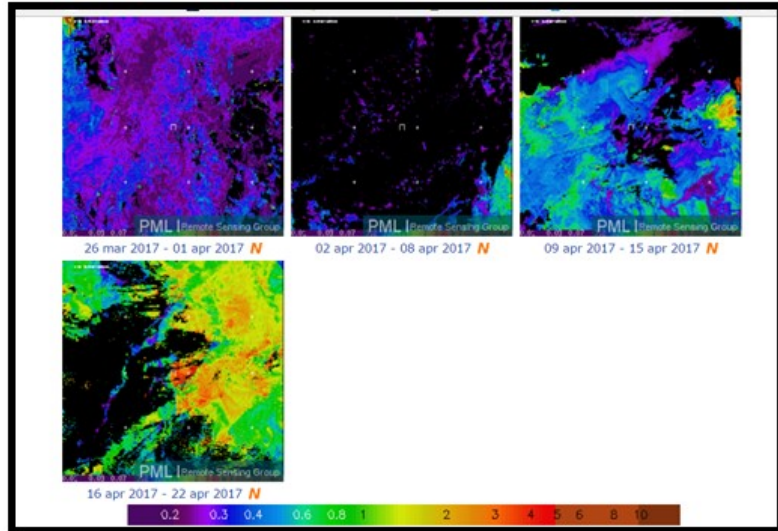
The PAP sustained observatory is about 600Km southwest of Ireland. Since 1989, this environmental study site in the Northeast Atlantic has become a major focus for international and interdisciplinary scientific research and monitoring including water column biogeochemistry, physics and seafloor biology. The first autonomous equipment included the sub-surface sediment trap mooring and the Bathysnap seafloor time-lapse camera system (both since 1989). Since 2002, a full depth multidisciplinary mooring has been in place with sensors taking a diverse set of biogeochemical and physical measurements of the upper 1000m of the water column. In 2010, collaboration between the Natural Environment research Council (NERC) and the UK Met Office led to the first atmospheric measurements at the site and this has continued since then to great effect.

The main mooring Ocean Data Acquisition System (ODAS) buoy ceased transmitting data in April 2016 immediately after deployment and since then the only information had been a location device installed by the



UK Navy in June 2016 (see photo). A high priority was therefore to recover the buoy and its stored data. In addition, we planned to recover a set of sediment traps which had been collecting sinking material in the lower part of the water column for the previous 12 months and then deploy a new set. The Bathysnap time-lapse benthic camera system had not been deployed in 2016 due to technical problems and the intention was to deploy a new one for recovery in 2018.

These are the autonomous systems we planned to work on, but as is usually the case with our expeditions to PAP, we also make observations on the temporal variability of the water column and seabed fauna - a task which is difficult or impossible to do autonomously. Furthermore, on this occasion we investigate sedimentation processes in the upper 1000m,



“the twilight zone” with colleagues from the USA and Germany using complementary approaches.

As can be seen from the montage of satellite images, phytoplankton growth started at about the time of our arrival at PAP.

IT and data management

Lisa Symes

4.1 Cruise overview

Cruise	Departure	Arrival	Technician
DY077 – PAP – R. Lampitt	14/04/2017 GBSOU	01/05/2017 GBPOR	Lisa Symes

4.2 Ship Scientific Computing Systems

Data was logged by the Techsas data acquisition system into NetCDF files and NMEA format. The format of both the NetCDF and NMEA files is given in the files located on the data disc in the following directory Cruise_Documentation\Data_Description_Documents. The calibration sheets and Met and underway sensors logged are given in Ship_Fitted_Scientific_Systems\Surfmet\DY077_sensor_calibrations.docx. Data was additionally logged into the RVS Level-C format, which is described in the NetCDF document.

During the cruise the Techsas data acquisition system had to be turned off to investigate a storage issue on the Techsas virtual machine. Please see the outage events below:

Date and time logging stopped**Date and time logging started**

Jday	Date	Stop Time	Jday	Date	Start Time
116	26/04/2017	10:09:00	116	26/04/2017	10:10:00
116	26/04/2017	10:37:46	116	26/04/2017	10:40:01
116	26/04/2017	10:46:10	116	26/04/2017	10:53:12

4.3 Position and Attitude

All GPS and attitude measurement systems were run throughout the cruise. The Seapath330 system is the vessel's primary GPS system, outputting the position of the ship's common reference point in the gravity meter room. The POSMV is the GPS that is repeated around the vessel and sent out to other systems. The Fugro Seastar 9205 is the primary differential GPS system used for the Seapath. The CNAV is the primary differential GPS system used for the POSMV. The PHINS GPS system supplies the ADCP75 and 150 with position and attitude data

Throughout this cruise POSMV is the primary GPS used for the EM122, EM710 multibeam systems and Sonardyne USBL.

SeaPath330, POSMVDData, CNAV, Fugro Seastar and Phins GPS systems were logged by the Techsas data acquisition system into NetCDF and NMEA files.

The Techsas module logging the Seapath positions crashed on one occasion causing a gap in the ships Seapath330 data in the NetCDF, NMEA and Level-C files. The dates and times of this gap is given below:

Date and time logging stopped**Date and time logging started**

Jday	Date	Stop Time	Jday	Date	Start Time
108	18/04/2017	16:29:56	109	19/04/2017	14:03:21

4.4 Meteorology and Sea Surface Monitoring Package

The Surfmet system was run throughout the cruise. Please see the separate BODC information sheet DY077_sensor_calibrations.docx located in the following location Ship_Fitted_Scientific_Systems\Surfmet\ for sensors used throughout the cruise. The sensor calibration sheets are included in the directory Ship_Fitted_Scientific_Systems\Surfmet\Surfmet_calibration_sheets.

The Non-Toxic water supply turned on 14/04/2017 15:30.

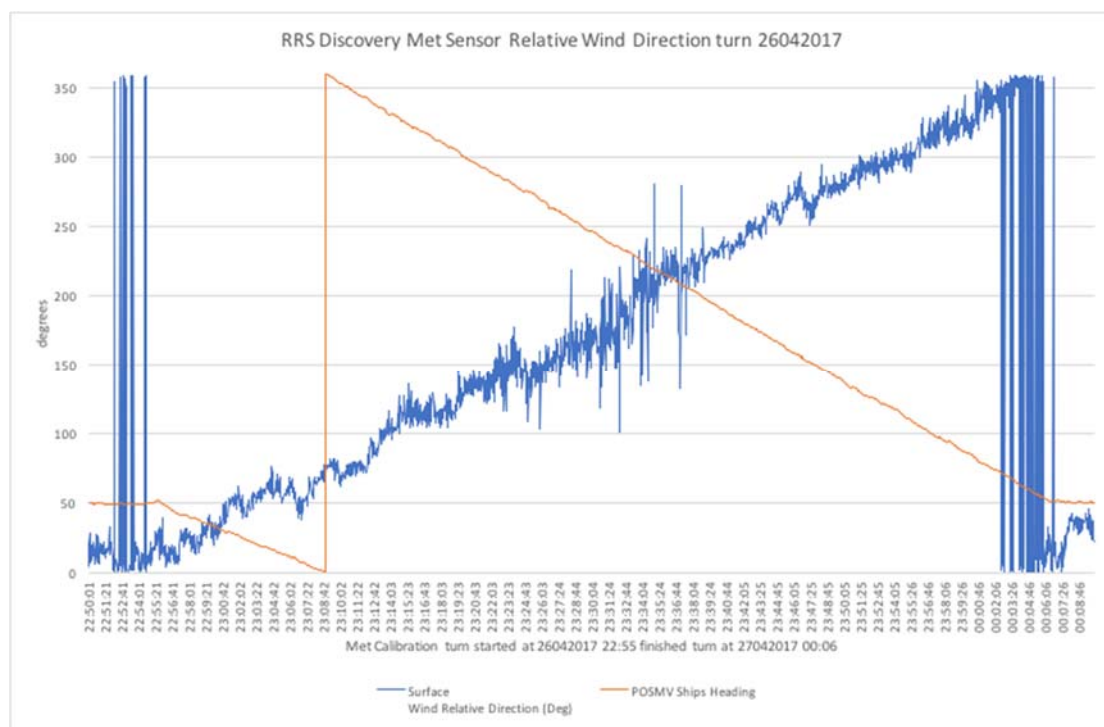
The pump for the non-toxic supply tripped on two occasions in the early hours of the morning this stopped the non-toxic supply to the Surf sensors and PCO2 system. There is no gap in the data but erroneous readings were logged on these occasions. The dates and times of the non-toxic pump stopping are given in the table below:

Date and time logging stopped

Date and time logging started

Jday	Date	Stop Time	Jday	Date	Start Time
105	15/04/2017	01:58:00	105	15/04/2017	07:57:00
111	21/04/2017	03:44:00	111	21/04/2017	08:47:00
120	30/04/2017	21:00:00			

To calibrate the met wind sensors on board *Discovery* the ship performed a 360 degree rotation around the head on the spot turn on 26042017. Please see a plot below (Station Number 101) turn started at 22:55 26042017, turn finished at 00:06 27042017. The Sea Surface Relative Direction and POSMV Ships Heading are shown.



4.5 Kongsberg EA640 10 & 12kHz Single Beam EchoSounder

The EA640 single beam echo sounder 10kHz frequency was active throughout the cruise, the 12kHz frequency was set to passive throughout. Except when the mooring release transducer was used and all acoustics were asked to be turned off. The EA640 was used with a constant sound velocity of 1500 m/s through the water column to allow it to be corrected for sound velocity in post processing.

Depth values from the EA640 were logged to Techsas to obtain NetCDF and NMEA files, also Level C files were produced. Files were also saved as .BMP images and in raw Kongsberg format.

4.6 Kongsberg EM122 and EM710 MultiBeam Echo Sounders

The EM122 deep multibeam echo sounder was run throughout the cruise and was synchronised to the K-Sync synchronisation system throughout.

The EM710 shallow multibeam echo sounder was run at the beginning of the cruise until the continental shelf drop off.

4.7 Sound Velocity Profiles

The sound velocity profile used in the EM122 multi-beam and USBL systems are shown in Appendix A. The profile was derived from Valeport SVP S/N 41603. This profile was used throughout the cruise. The EA640 and EM122 as reference depths.

4.8 75kHz & 150kHz Hull Mounted ADCP Systems

Both the 75 kHz and 150 kHz ADCP systems were run during the cruise. The raw data files and configuration files are included on the data disk. Both systems were not synchronised to the K-Sync synchronisation system.

4.9 Gravity Meter

The gravity meter was on board for this cruise however the gravity meter was not requested therefore no data was logged.

4.10 WAMOS Wave Radar

The WAMOS wave radar was run for the first 2 days of the cruise. However the PC power Supply failed, as a result there is no data from the wave radar on the disk after 16/04/2017. The data can be found in Ship_Fitted_Scientific_Systems\WaMoS.

4.11 CTD, LADCP, Salinometer & Moorings

The CTD, Salinometer and Moorings data are included in the Sensors_And_Moorings folder

4.12 Sound Velocity Profile Details

Jda	Date	CT No.	Time St	Time a Bottom	Dept Cast	Lat	Lon	Time applied to SIS	Comments
107	17041	003	00:31:19	01:59:3	4877	49° 16.849	011° 34.00242 W	107 170417 09:20	41603 Valeport SVP deployed on CTD frame

5 Mooring Operations

Nick Rundle and Steve Whittle

5.1 PAP#1

The original plan on the program was to do a full deployment of a new PAP#1 mooring and then complete recovery of the old PAP#1 mooring. Unfortunately the mooring objectives for the cruise were reassessed during mobilisation. Whilst winding on the mooring rope onto the large PAP mooring winch, it was discovered that the last box which should have contained just over 700m of rope was empty. As it was not possible to source more rope before the ship disembarked the full mooring replacement had to be abandoned

The current rope and Ixsea release were deployed from the FS Meteor in 2014, The Met office who supply the rope and ODAS buoy recommend a maximum deployment time of 5 years for the rope and a similar limit is suggested by Ixsea for the release.

In addition the Met Office recommended and supplied a new thimble and tail which was spliced in by Andy Maclean (boson) using 10 tucks each side over a length of just under 2m. The old thimble showed a small amount of corrosion with minimal wear on the rope.

5.1.1 PAP#1 Recovery

The PAP#1 ODAS buoy was hooked from the aft deck red zone and lifted onto deck using the A frame and the GP winch through the block. The PAP#1 winch assisted pulling the keel into position.

The Sensor frame hanging on 30m of chain below the buoy keel was hauled up using the 5T deck winch and then craned using the starboard pedestal. After the frame was disconnected, the length of rope and thimble to be replaced in the splice was hauled on deck

After the splice had been completed a 2 ton suitcase pendant anchor buoy fitted with a Novatech light and Iridium beacon was connected to the new thimble and released from the A frame on the GP winch temporarily while the new sensor frame and ODAS buoy were prepared.

After the recovery of PAP#1 onto the aft deck it was noted that the GP Winch saw a constant load of 8T, there was fouling half way up the stainless frame work, could this



suggest that the ODAS buoyancy is taking on water or battery housing flooded? On deployment of the replacement buoy the winch saw a constant load of 5T.5T deck winches not ideal for mooring operations.

Figure 1 2016 PAP#1 on retrieval

The cause of the 2016 power and comms failure on the buoy is not immediately obvious and will probably not be reported until next year's cruise. The only immediate failure was the bracket to the SeaGuard and optode which was missing. It is apparent from the lack of fixings or bracket remnants that the top part of the bracket was never bolted down and had probably fallen out of its base during or shortly after deployment.

5.1.2 PAP#1 Deployment

In order to prevent the power/communication failure that happened almost immediately after deployment of the 2016 PAP#1 deployment, the technical team had managed to get the sensor frame and ODAS buoy connected up and operating a fortnight before mobilisation, this greatly reduces the amount of technical time used preparing the instrument frame and buoy prior to deployment on the ship and allows for a far more thorough pre deployment check. The checks involved a thorough inspection of all brackets bolts and connections.

Similar to the ODAS Buoy the 2 ton buoy was hooked from the back deck and brought back on board using the GP winch. The connection was then transferred to the bottom of the frame.

The Frame was positioned in the red zone quite close to the starboard pedestal. The *Discovery* starboard crane is not able to knuckle in enough to pick up the sensor frame in this location so the Rexroth winch on the A frame gantry was used to pick up and lower the frame overboard. Once the load is transferred to the 5 Ton deck winch the remaining chain is aid out. The Odas Buoy is connected to the GP winch with a SeaCatch and released overboard on the A frame.

5.2 PAP#3

5.2.1 PAP#3 Deployment

A pre mooring deployment calibration dip of the CTD containing the IXSEA release units and SeaBird 37IMP to 4800m was performed. The deck unit was connected to the ships drop keel, which has had a new transducer cable fitted from the keel to the lab, and all release units fired OK and gave good depth ranges.

There was no DB (Double Barrel) Winch on the deck for this cruise due to space constraints so the PAP#3 mooring was deployed and recovered using the port side 5T deck winch and aft starboard pedestal crane.

To keep the time series running without a gap the new PAP#3 mooring is always deployed before the old one is retrieved. This also helps maximise available deck space, which is severely limited when the PAP#1 winch is on board.



On deployment and recovery of the PAP#3 mooring, the port side 5T deck winch was used, this winch is not ideal for mooring operations. When there is a full drum of rope or wire there is the potential for the mooring line to rub against the frame work of the winch, this problem was alleviated by keeping the hanging block on the crane low to the deck and also by using a snatch block when height was required to bring the Sediment traps onto the deck. The recovery also required a number of carpenters wedges to deal with the tangles installed in the mooring whilst returning to the surface and awaiting recovery.



5.2.2 PAP#3 Position

The PAP#3 mooring was ranged and triangulated to give the positions in the following table.

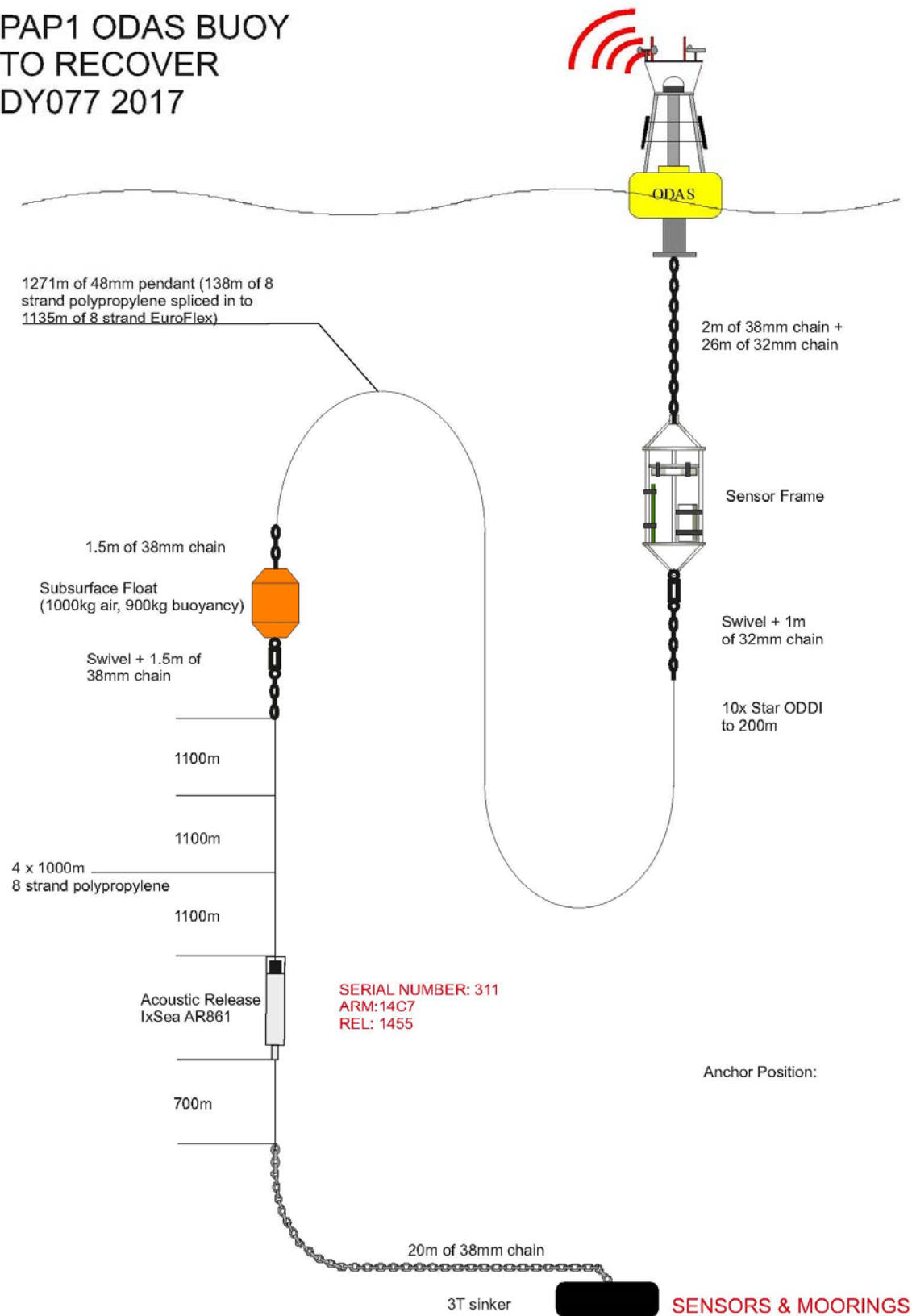
LATITUDE			LONGITUDE		
00°	00.'0000	Quad	000°	00.'0000	Quad
49°	00.2400'	N	016°	27.8160'	W

5.3 Other Moorings Operations

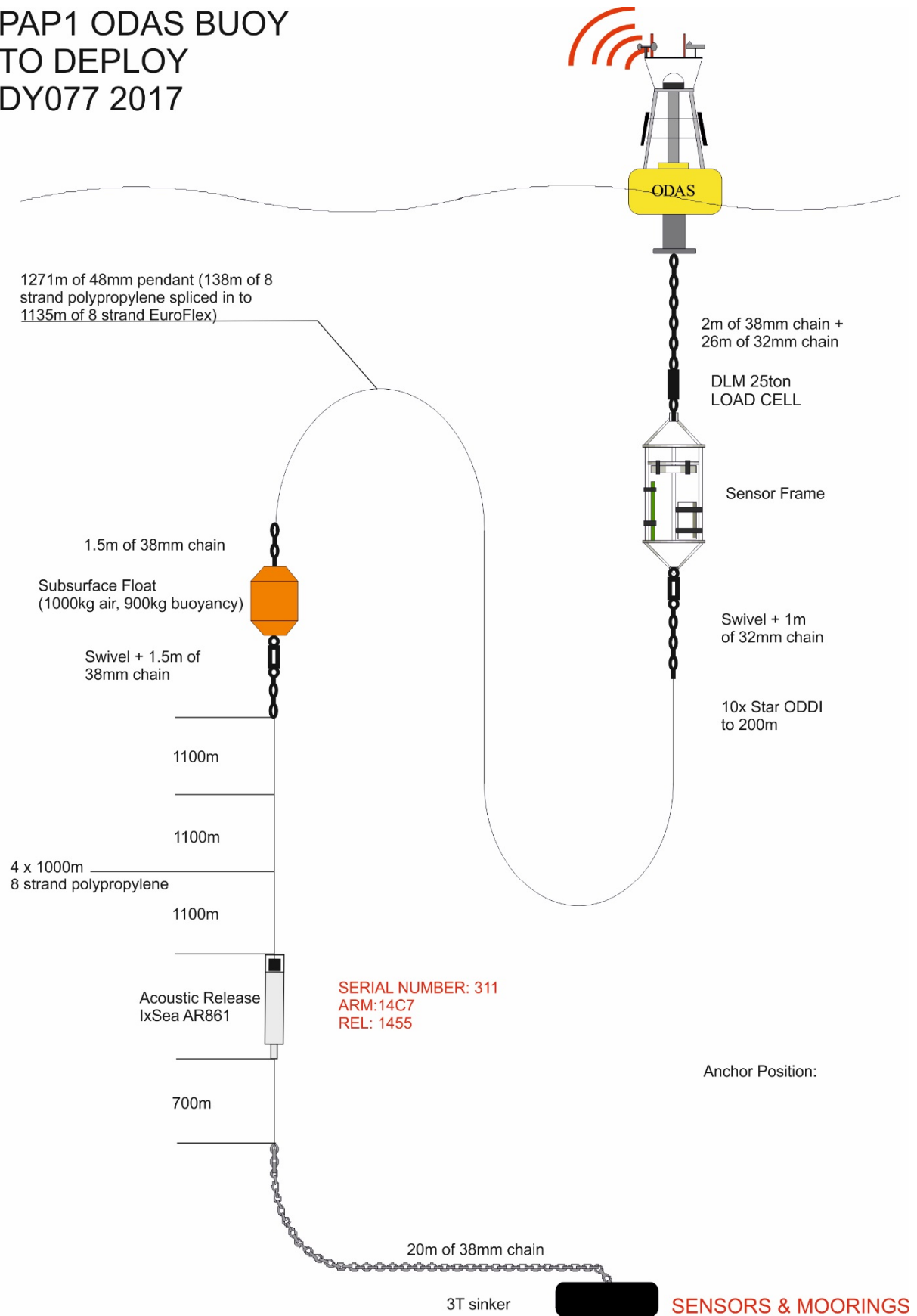


The moorings team also provided the consumables and operational support for the Bathysnap camera frame which is also deployed annually and the Amphipod Traps which are landed on the seabed for 24 to 36 hours at a time.

PAP1 ODAS BUOY TO RECOVER DY077 2017

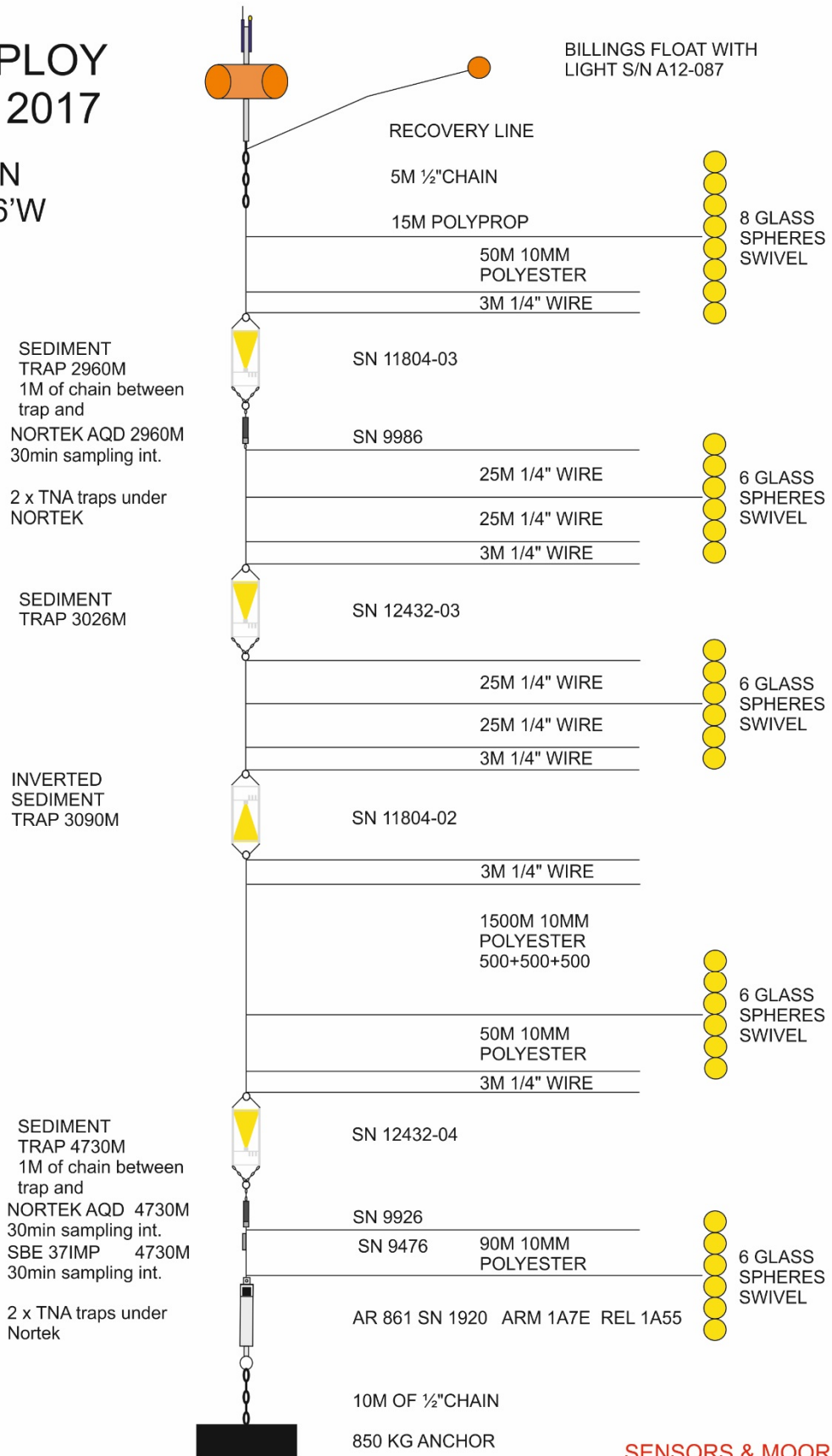


PAP1 ODAS BUOY TO DEPLOY DY077 2017



PAP 3 TO DEPLOY DY077 2017

49 0.300'N
16.27.886'W



SENSORS & MOORINGS

PAP 3 TO RECOVER Dy077 2015

49 0.45'N
16 29.59'W

KMT-321
2930M

SEDIMENT
TRAP 2997M
2 x TNA traps
clamped to frame

NORTEK AQD 3000M
30min sampling int.

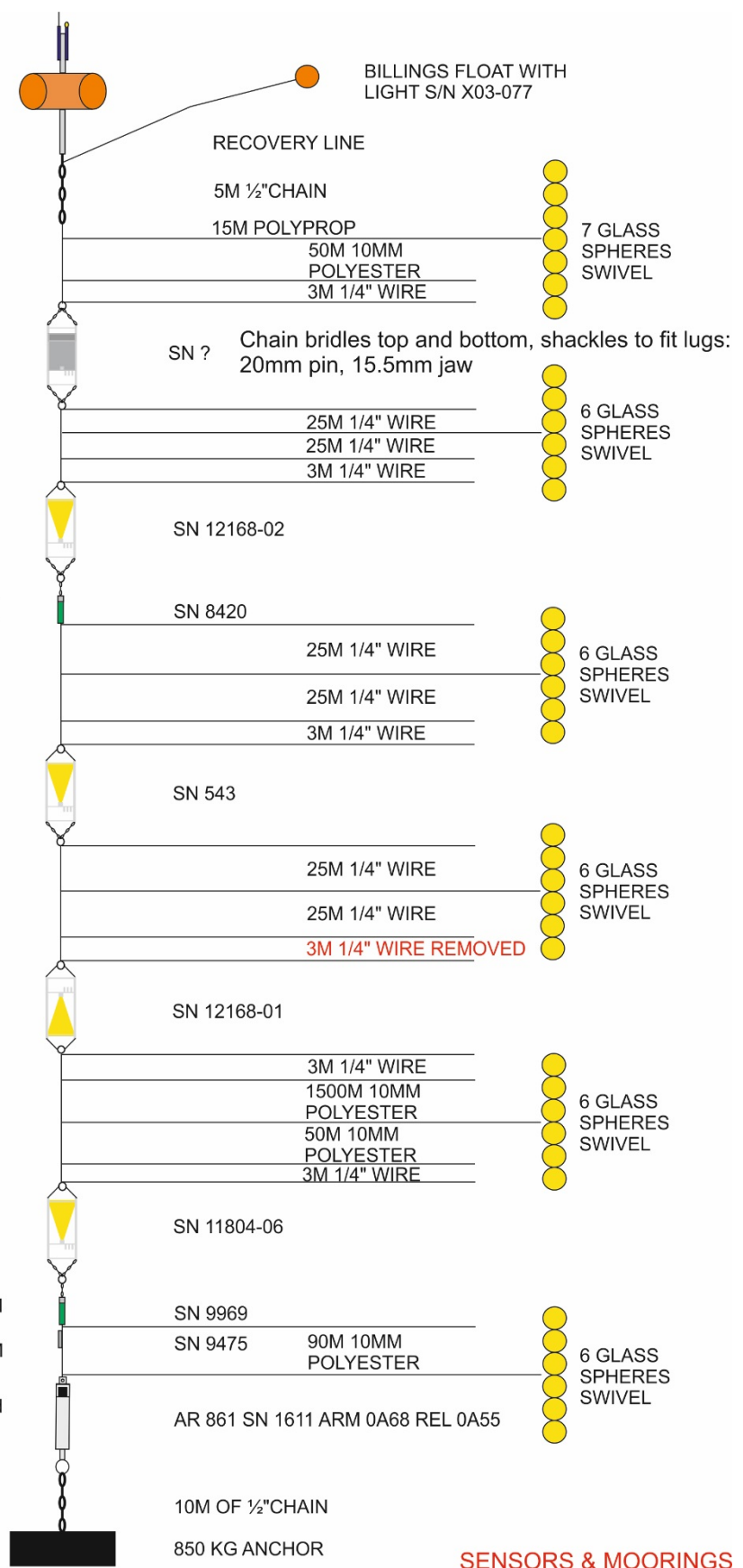
SEDIMENT
TRAP 13way
3065M

INVERTED
SEDIMENT
TRAP 3130M
WIRE BRIDLE
BOTH ENDS

SEDIMENT
TRAP 4732M

NORTEK AQD 4734M
30min sampling int.
SBE 37IMP 4735M
30min sampling int.

2 x TNA traps clamped
Approx 45m below
Sediment trap



SENSORS & MOORINGS

6 Ocean Engineering Group Technical Report

Owain Shepherd

6.1 Romica General Purpose Winch (PAP)

Inv. No. : 250008034

Prior to operation of PAP mooring winch it was necessary to link out HPU E/Stop circuit. This was achieved by introducing a link between point 201 and 202 thereby bypassing E/Stop circuit 12SB1 in the HPU system ISO container. Thus a 24V supply is maintained to relays *12KM1 and 12KM2 and enabling normal operation of winch system. This is a temporary* measure for DY077, a permanent hard wired switched link located with the winch control panel is required. This will enable swift and easy switch over for when winch system is to be used with either ship fitted HPU system or portable containerised HPU system where E/Stop circuit 12SB1 is required. A similar link out operation can be conducted in order for the containerised HPU to operate independently from the Romica General Purpose Winch should this be required. This can be achieved by introducing a link between point XTS1 001 and XTS1 002 in the HPU starter panel and thereby bypassing E/Stop circuit 12SB1 in the winch starter panel.

PAP mooring rope was wound on at NOC Southampton prior to port departure. Automatic scrolling was found to be an issue due to the requirement for shackles and links to be utilised in order to join mooring rope lengths. Scrolling issue was overcome by manually controlling scrolling from the Serco remote control box during winding procedure. An additional cause of automatic scrolling issue was that the mooring rope was wound on when not under tension thereby affecting rope diameter and uniformity of lay on winch drum. This caused further issues when the Pap winch was used to haul in the base end of the PAP buoy during recovery operations. The mooring line when put under tension during the haul procedure dug in to the loose lays on the drum resulting in rope jam. Method of rectification was hand baling off of jammed line by technicians and then hauling back on line to winch drum. It is suggested that PAP mooring line be removed from PAP winch and then reeled back on under tension in order to prevent reoccurrence of issue.

During PAP operations it became evident that there is a slight oil leak between the matting faces of the gearbox and break assembly. Further investigation will be necessary to ascertain as to whether this is gearbox or break oil however break oil was still observed in level sight glass throughout DY077.

It is suggested by O.E.G. technician that all flexible hydraulic hoses utilised on winch system be changed for conical BSP type hose fittings. This will both save on time and cost of sourcing replacement hydraulic hoses as conical BSP type hydraulic hoses can be manufactured in house by qualified O.E.G. technicians. An extensive hydraulic hose spares kit can then be assembled for minimal cost that will then travel with winch system on subsequent research expeditions. This action

will safeguard against long periods of unserviceability due to hydraulic hose failure, especially when in expedition service.

6.2 Romica Multi-Purpose Winch

Asset No. : 193651

Issues of configuration on deck matrix with intention for PORT side deployment operations were discussed with Operations Officer during mobilisation period. It was suggested by O.E.G. technician to site winch system for STBD side deployment operations as per PAP expedition 2016 as this would enable two wires to be deployed on the STBD side at the same time and therefore significantly increase scientific sampling rate. Operations Officer insisted winch system was to be sited for PORT side deployment operations. Once RSS *Discovery* had deployed for DY077 the Master became aware of this configuration and it was deemed both safer and more practical to re-site winch system for STBD side deployment operations. This evolution was conducted in a safe manner by O.E.G. technician and ship's crew with the ship heaved to. Substantial work was necessary to re-route hydraulic and electrical supplies for both the Romica Multi-Purpose Winch and the Romica Purpose Winch as a direct result of not heeding O.E.G. technician's suggestion during mobilisation period.

Winch system was utilised on DY077 for the deployment of the Red Camera Frame and Snow Catcher System on multiple occasions. System operated without significant issue however it was necessary to manually adjust auto-scrolling periodically. This will be an ongoing issue with this winch system due to there being no 8mm diameter shells fitted to winch drum and scrolling auto-stops are not fully calibrated for 8mm diameter wire.

6.3 Lebus 5 Ton Winch (Port Fit)

Inv. No. : 250008661

Winch system operated without mechanical issue throughout DY077. It was utilised for the recovery and deployment of the PAP#3 mooring, OTSB trawls, Amphipod Traps and NTST moorings. Siting of winch one metre inboard from issued deck plan site would have significantly improved ease with which deployment and recovery operations were conducted as fleeting angle both laterally and longitudinally with mooring block on PORT pedestal crane would be improved. In addition winch was sited in incorrect orientation resulting in cable streaming off the top of the winch drum instead of from beneath. Winch housing cross member above winch drum subsequently became an obstruction issue when it was necessary to elevate mooring block during recover of sensors on moorings. North Sea winch systems do not have this issue regardless of orientation and whether cable is streaming

from over the top or beneath the winch drum. It would be beneficial to remember this when planning future mooring evolutions.

Lebus 5 Ton Winch (STBD Fit)

Inv. No. : 250008659

See comments above.

6.4 Liquid Nitrogen Generator (Orange Frame)

Inv. No. : 250000027, 250009648, 250008402, 250000005

System operated without issue for the duration of DY077. LN2 requirements were minimal therefore surplus was disposed on a daily bases in order to keep system producing LN2. This practise has prevented the issue of ice crystals developing in level gauge pipework and subsequently making it necessary to purge and restart system.

6.5 Mega Core System

Inv. No. : 250003118

Normal system operation achieved throughout expedition. Consumables use was minimal.

6.6 Milli Q Integral 15 System

Normal system operation was experienced throughout DY077 with the exception of a minor malfunction with Milli Q system situated in the General Purpose Laboratory. Progard filter cartridge experienced a high pressure leak from the connection point. This occurrence was several days after re-commissioning of Milli Q system. Progard filter cartridge had been fitted and normal operation proven by competent O.E.G. technician adhering to Milli Q system instruction manual. Further inspection of Progard filter cartridge showed an O-ring seal to be improperly seated, a visual inspection of O-rings prior to installation had shown no such issue. In order to maintain system integrity defective Progard filter cartridge was replaced as per operator manual and normal operation of system was observed for the remainder of DY077.

6.7 RN Laboratory Container

Inv. No. : NMFU2002252

Service supplies for RN laboratory container embarked on DY077 were non-toxic sea water and 440V 63A 3 phase power supply. All other services were not deemed to be required by the embarked scientific party following discussion with O.E.G. technician. Normal system operation was maintained throughout expedition.

7 NMF Sensors and Moorings CTD

James Burris

7.1 Introduction and over view:

DY077 covered the PAP expedition for 2017. See table below for summary of CTD casts. Due to OTE group having sensors on the carousel, only 21 20ltrs bottles were installed. These were in positions 1-21.

On the first three casts there were some issues with the configuration file for the transmissometer and the Chelsea Fluorimeter being on the wrong channels. This was corrected by swapping round the channels in the software that they were assigned to. The XML. CON files were then changed to reflect this, so that when the data was replayed it was correct.

The Dissolved oxygen values also appeared incorrect on the first two dives, due to short turn around time, it was decided to continue with the sensor on cast 003, at which point it became very clear that the instrument was faulty. Once returned to surface, after cast was complete the sensor was replaced for S/N: 43-2818.

On the first deep cast (cast 003) it became apparent that the altimeter was incorrectly set up. The cast was completed without incident (CTD package no closer than 35m to sea bed). On surfacing the problem was investigated and it was found it had a scale factor of 1 in its set up, this was then changed to its correct value of 15.

Due to the problems on the first three dives, it has been suggested that in the future PAP cruises that a shallow CTD be carried out as test cast to check all sensor readings including altimeter.

Occasionally bottle 9 would not fire. The solenoid had triggered but the mechanism jammed. This was rectified by fully cleaning with triton X solution and re aligning the bottle arming line with the use of cable ties attached to the top of the CTD frame. This worked well and the bottle performed well for the rest of the cruise.

The CTD's then carried on without incident until cast 013, when it became apparent (at around 100m depth) there was a significant difference (approx. 40m) between CTD depth and displayed wire out.

Initially it was thought the digi quartz pressure sensor on the CTD was the issue. However, this was proved to not be the case. This was done by deploying the CTD with a separate SBE 39 sensor. The data from the SBE39 agreed with the CTD data. On inspection by the ships engineers, it became apparent the problem was caused by the cable counter having become disconnected and the coefficients were incorrect. This was rectified and CTD's carried on as normal.

Technical Note: Throughout the cruise, it was found that the IBM mice for the CTD computer would lock up. Several different USB ports were tried with the same effect and the mouse was changed for another (IBM) mouse. Unfortunately, this had the same result. This proved to be problematic whilst trying to operate the seabird software when carrying out a CTD. It's recommended that these be changed out when back at base.

The sea cable (CTD 2) had a new mechanical and electrical termination prior to the start of the cruise. This was load tested as per procedure and periodically checked for electrical resistance. It has performed well for the entire cruise.

7.1.1 Summary of CTD casts

Cast number	Station Number	Max depth	Notes
OO1	OO1	103m	D.O possibly not working, trans and flor on wrong channels
OO2	OO5	30m	Test cast to check sensors. D.O Not working, trans and flor on wrong channels
OO3	OO7	4784m	DO Not working, (not changed due to short turn around and not critical for this cast) trans and flor on wrong channels. (Having issues getting the con file to be set up correctly). Altimeter found to have scale offset of 1 instead of the required value of 15.
OO4	O31	352m	New DO installed, trans and flor now on correct channels
OO5	O33	350m	
OO6	O35	350m	
OO7	O48	4822m	Altimeter working fine. (now has correct scale factor)
OO8	O49	350m	
OO9	O51	350m	
OO10	O55	350m	
OO11	O58	100m	
OO12	O60	350m	
OO13	O74	350m	Aborted at 100m on the return to surface due to issues with wire out being incorrect by 40m
OO14	O75	100m	Aborted at 100m due to error on wire out being still present. Cast was done to see if the error was the pressure sensor on the CTD
OO15	O77	350m	Deployed with SBE39 attached to frame to confirm if the sheave counter was the problem, or the SBE9 pressure sensor. On checking the SBE 39 the two pressures were the same, this proved the sheave counter was the casue of the error.
OO16	O78	350m	
OO17	O79	350m	
OO18	O85	4828m	
OO19	O89	350m	
OO20	O91	350m	
OO21	O97	349m	
OO22	105	1000m	
OO23	106	350m	

7.1.2 List of sensors

Sensor information sheet for Cast 001,002 and 003

SENSOR INFORMATION

SHIP: RRS <i>DISCOVERY</i>	CRUISE: DY077
----------------------------	---------------

FORWARDING INSTRUCTIONS / ADDITIONAL INFORMATION: Main Stainless Steel 24-way CTD frame as shipped for DY077
--

Checked By: R Craft	DATE: 14 April 2017
---------------------	---------------------

Instrument / Sensor	Manufacturer/ Model	Serial Number	Channel	Casts Used
Primary CTD deck unit	SBE 11plus	11p-0676	n/a	001,002 and 003
CTD Underwater Unit	SBE 9plus	09p-0943	n/a	001,002 and 003
Stainless steel 24-way frame	NOCS	SBE CTD1	n/a	001,002 and 003
Primary Temperature Sensor	SBE 3P	3p-2674	F0	001,002 and 003
Primary Conductivity Sensor	SBE 4C	4c-2571	F1	001,002 and 003
Digiquartz Pressure sensor	Paroscientific	110557	F2	001,002 and 003
Secondary Temperature Sensor	SBE 3P	3p-4383	F3	001,002 and 003
Secondary Conductivity Sensor	SBE 4C	4c-2580	F4	001,002 and 003
Primary Pump	SBE 5T	05-3085	n/a	001,002 and 003
Secondary Pump	SBE 5T	05-7371	n/a	001,002 and 003
24-way Carousel	SBE 32	32-0423	n/a	001,002 and 003
Dissolved Oxygen Sensor	SBE 43	43-1624	V0	001,002 and 003

Altimeter	Benthos 916T	59494	V2	001,002 and 003
Light Scattering Sensor	WETLabs BBRTD	BBRTD-169	V3	001,002 and 003
PAR Up-looking DWIRR	Biospherical QCP Cosine PAR	70510	V4	001,002 and 003
PAR Down-looking UWIRR	Biospherical QCP Cosine PAR	70520	V5	001,002 and 003
Fluorometer	CTG Aquatracka MKIII	88-2615-126	V7	001,002 and 003
Transmissometer	WET Labs C- Star	1602TR	V6	001,002 and 003
20L Water Samplers	OTE	1-24	n/a	001,002 and 003

Note: items in bold were changed around after cast 003.

Sensor information sheet for Cast 004 onwards.

Instrument / Sensor	Manufacturer/ Model	Serial Number	Channel	Casts Used
Primary CTD deck unit	SBE 11plus	11p-0676	n/a	004 including and onwards
CTD Underwater Unit	SBE 9plus	09p-0943	n/a	004 including and onwards
Stainless steel 24-way frame	NOCS	SBE CTD1	n/a	004 including and onwards
Primary Temperature Sensor	SBE 3P	3p-2674	F0	004 including and onwards
Primary Conductivity Sensor	SBE 4C	4c-2571	F1	004 including and onwards
Digiquartz Pressure sensor	Paroscientific	110557	F2	004 including and onwards
Secondary Temperature Sensor	SBE 3P	3p-4383	F3	004 including and onwards
Secondary Conductivity Sensor	SBE 4C	4c-2580	F4	004 including and onwards
Primary Pump	SBE 5T	05-3085	n/a	004 including and onwards
Secondary Pump	SBE 5T	05-7371	n/a	004 including and onwards
24-way Carousel	SBE 32	32-0423	n/a	004 including and onwards

Dissolved Oxygen Sensor	SBE 43	43-2818	V0	004 including and onwards
Altimeter	Benthos 916T	59494	V2	004 including and onwards
Light Scattering Sensor	WETLabs BBRTD	BBRTD-169	V3	004 including and onwards
PAR Up-looking DWIRR	Biospherical QCP Cosine PAR	70510	V4	004 including and onwards
PAR Down-looking UWIRR	Biospherical QCP Cosine PAR	70520	V5	004 including and onwards
Fluorometer	CTG Aquatracka MKIII	88-2615-126	V7	004 including and onwards
Transmissometer	WET Labs C-Star	1602TR	V6	004 including and onwards
20L Water Samplers	OTE	1-24	n/a	004 including and onwards

7.1.3 Detail of transmissometer calculation of coefficients.

On the initial three casts it was noticed that the transmissometer was giving lower readings than expected for percentage transmission. An in-situ “dark count” reading was taken on deck and this was added to the sensors and moorings calculations spread sheet. However, this still gave lower transmission readings than expected. (approx. 20% in air) After discussion with Dr Megan Estapa (of Skidmoore College working in conjunction with W.H.O.I and an on-board scientist using transmissometer data) the following formula was used to calculate the coefficients for the transmissometer;

$$V_{ref} = 4.699 (W0)$$

$$V_{Dark} = 0.0037 (Y1)$$

Therefore;

$$M = \frac{1}{V_{ref} - V_{Dark}} = \frac{1}{4.6953} = 0.21298$$

$$B = \frac{-V_{dark}}{V_{ref} - V_{Dark}} = \frac{-0.0037}{4.6953} = -0.00078802$$

To out put in %;

$$M = 21.298$$

$$B = -0.078802$$

7.1.4 CTD processing overview

CTD data was processed as per BODC document.

In addition to this, sigma theta derived for some casts, on others density /m³ was derived.

Initially the config file for cast 001-003 was incorrect. Transmissometer and Fluorimeter being swapped on the wrong channels. In the Appendix the original config file can be found.

However, in order to recover the transmissometer and fluorimeter data another config was created with the correct channels assigned.

See table below for summary.

7.1.5 Summary of processing of CTD casts

Cast number	Station Number	Max depth	Notes
001	001	103m	No Loop edit. Density kg/m3 derived
002	005	30m	No Loop edit. Density kg/m3 derived
003	007	4784m	No Loop edit. Density kg/m3 derived
004	031	352m	No Loop edit. Density kg/m3 derived
005	033	350m	No Loop edit. Density kg/m3 derived
006	035	350m	Density Sigma- Theta derived
007	048	4822m	No Loop edit. Density kg/m3 derived
008	049	350m	Density Sigma- Theta derived
009	051	350m	Density Sigma- Theta derived
0010	055	350m	Density Sigma- Theta derived
0011	058	100m	No Loop edit. Density kg/m3 derived
0012	060	350m	Density Sigma- Theta derived
0013	074	350m	Density Sigma- Theta derived
0014	075	100m	Density Sigma- Theta derived
0015	077	350m	Density Sigma- Theta derived
0016	078	350m	Density Sigma- Theta derived
0017	079	350m	Density Sigma- Theta derived
0018	085	4828m	No Loop edit. Density kg/m3 derived
0019	089	350m	Density kg/m3 derived
0020	091	350m	Density kg/m3 derived
0021	097	349m	No Loop edit. Density kg/m3 derived
0022	105	1000m	No Loop edit. Density kg/m3 derived
0023	106	350m	No Loop edit. Density kg/m3 derived

8 PAP#1 Observatory Report

Corinne Pebody, Katsia Pabortsava, Chelsey Baker, Sue Hartman and Miguel Charcos Llorens

8.1 General Description

The PAP0003 system comprises a buoy telemetry electronics unit and a frame data hub unit. Sensors in the frame and buoy connect to PAP003 and their data is sent using Iridium to our server at NOC. The telemetry communication is intended to provide remote quasi-real time data. Schematic drawings of these two units as configured for the latest deployment are shown in Figure 6 and Figure 7. The buoy also hosts an entirely separate system provided by the UK Met Office which has its own Iridium telemetry unit and a suite of meteorological sensors measuring wind velocity, wave spectra and atmospheric temperature, pressure and humidity.

The goal during this cruise is to recover the data from the sensors of the frame and the buoy as well as the PAP0003 system that were deployed on April 2016. Then, deploy the new set of electronics and sensors that will be acquiring data for a year between 2017 and 2018. The PAP#1 mooring rope will be re-used but the Met Office is providing a newly refurbished buoy (including flotation, mast, power system and keel) with new equipment. The buoy was painted with a copper base paint to decrease the growth of organisms at the base that happen every year and affects the measurements (see Figure 2). The frame of the PAP0003 system hosting the sensors at 30m was refurbished. Some clamps were reused, some others were manufactured again by NMF in land and others redesigned and made on board by OTEG. The clamps in the buoy were reused from last recovery of the system that was deployed in 2015-2016. The clamps of the microCATs were reused from the buoy that we recovered this year. All science sensors were serviced and calibrated before deployment. Four new devices were attached to the frame.

The previous PAP#1 Observatory system was deployed on April 28th 2016 on cruise DY050. As described in DY050 expedition report, the buoy battery system failed to provide power in 2016 deployment and we did not received real-time data. For this reason, the recovery of the data that was internally logged in the sensors is a critical part of our current mission. The investigation of the causes of the failure is not included in this report since they will be performed in the next months in land following our expedition.

In this document, we describe the systems that were deployed in 2017 and the status of the system that was recovered from the deployment in 2016. We describe the observatory including the changes to the telemetry and data hub systems. A section is devoted to the calibration and configuration of the deployed sensors. We include a description of the status of the observatory after recovery and post-deployment calibration of the sensors that were deployed in 2015 and recovered during this cruise.

9 Deployed Observatory Description

9.1 Design modifications of the new observatory

9.1.1 Data Hub and Telemetry units

The previous Data Hub and telemetry system demonstrated being a good solution for the previous year deployments at PAP. These devices allowed us to investigate solutions to the challenge of acquiring real-time data in the PAP area. Unfortunately, the technology that we used is obsolete and the manufacturer of the microcontroller is about to close the company. OTEG is considering swapping technologies to the one that they use internally since it has shown to be very reliable, low power consumption and they have a large set of libraries to respond to the needs of the hub and telemetry units. We are planning to acquire a few spares of CF2 Persistors for the current units but we are going to start the transition to the SAM4L technology along the coming year. For this year's deployment, we used the same systems that were recovered last year. The PCB boards carry a Persistor CF2 microcomputer, two 8-channel UART (Universal Asynchronous Receiver transmitter) devices providing 16 serial communication ports and switched power supplies for some of the sensors. A small compass, pitch and roll board is mounted on the main PCB, along with temperature and humidity sensors. The electronics also include a triaxial accelerometer. We replaced the compact flash cards with a new set of new 2GB cards.

As for any other deployment, the PAP0003 system was tested at NOC for various weeks. The difference this year is that following the failure of the battery power at the buoy during last year deployment, all the groups put a lot of effort to have the systems ready before mobs to allow testing in land. The entire system including buoy, met office sensors, pap0003, main cable and sensors was tested for a few days before boarding the ship. It was a big milestone in the coordination of the PAP project and needs to be pursued in the following years. It simplified the preparation on board and increased the reliability of the deployment. Issues that were found during testing were easier to fix in land with a larger set of tools and human capability. Even more, if sensors can be clamped beforehand next year, the test may include a tank test where the frame can be tested in the water in order to test leaking failures. It seems to be the case that every year we find a sensor or harness that fails right when we deploy due to water leaks. This can be avoided by performing the water test for a week. In addition, to decrease the chances of harness failure, next year we are aiming to manufacture the harnesses externally. Following the CAD designs of the frame by Nick Rundles, we were able to model the harnesses using Inventor and we made the current ones following these models. The next step forward is to have them made by a company with cable manufacturing expertise to increase the reliability and decrease the cost and manufacturing time.

Another improvement in this year's preparation is the analysis of the power consumption of the sensors that we contracted to Campbell Ocean Data. We characterized the power consumption of the sensors in idle and measuring phases as well as their peak currents. The study was performed following the power failure last year but it is important for the understanding of the current system and the design of the new ones using new technologies. It is recommended to perform the power study as routine during the preparation of the cruise in the coming years since this would allow us to make sure that the sensors behave as expected before deploying them at sea. Because the study was performed after the harnesses were ready and tested, no change was made following the study for this year deployment. However, it allowed us to find out that the use of the batteries could be optimized in future deployments. The only change on the harnesses was done to the one connecting the GTD at the frame. In fact, the GTD has an internal logger which allows the sensor to log data without the need of the data hub. Therefore, powering the sensor externally would allow (contrary to previous years) to obtain pressure data even in case of failure of the PAP0003 or MetOffice's buoy systems. The GTD was connected to one of the Oceansonics batteries that power the CO2 sensor. Thus, the CO2 sensor has now a single external 200Ah Oceansoics battery. This would allow the sensor to run autonomously most of the year and the entire year with the help of the battery power during the summer. After deployment, the configuration of the batteries will be reviewed for next deployment.

Another important change this year was made to the cable between the buoy and the frame. It was replaced this year because the stock of orange cable was gone. Two hundred meters of cable with similar characteristics was purchased to Hays Cables which will be used in the next coming years. It was fitted with a hydraulic hose along the entire length up to the middle of the buoy. The side that was connected to the frame, as in previous years, was fitted with a larger hose over the chain and the cable to avoid the chain pinching the cable. The hose was reused from the system that we previously recovered (see Figure 2).



Figure 2: Buoy-to-Hub cable inside hydraulic hose clamped to mooring chain. At the bottom you can see the buoy with copper paint.



Figure 3: Sensor frame being deployed showing large hydraulic hose over mooring chain

This year, the PAP#1 observatory incorporated 4 new stand-alone sensors in the frame. They are not connected to the data hub in will be logging data internally. The first sensor is a CT sensor provided by OTEG. It is a thin tube (~3cmx10cm) that was attached with jubilee clips to one of the bars of the frame. It has a 9V battery cell inside that will allow it to take measurements for the deployment (see Figure 5). This sensor will stand its first long term deployment test this year. The same is true about the nitrate sensor provided by OTEG. We provided a 102Ah Satlantic battery, the electrical harness and the clamp for this sensor. The sensor will log nitrate data for the entire year. The sensor took a large amount of space and because the frame is already very populated it will be hard to add more medium/large size sensors to it in the future. Another device was added with the purpose of measuring the mechanical stretches of the chain. It was coordinated by NMF with the objective of modelling the loads in the chain for the design of the next version of frame and link between the buoy and the frame. The sensor and the logger were powered with one of the old Oceansonics 206Ah batteries that were recovered in 2016. The logger is in a small housing that was clamped at the top of the frame. The load cell was placed between the last link of the chain and the frame shackle. The load cell is connected to the logger in the housing via an underwater cable that also provides power to the load cell. The 4th

new device is a VR2W passive acoustic device to listen to Bluetooth signals from animals with tracking chips. It has its own internal battery and it is completely autonomous (see Figure 4).



Figure 4 - Top of the frame showing the logger white housing for the load cell and the VR2W (horizontal tube) Figure 5 - CT sensor

9.1.2 PAP0003 Software and Hardware Updates

A duplicate of the current PAP0003 system was used for the 2017' deployment. Figure 6 and Figure 7 illustrate the systems connected to PAP0003. The differences between the two electronics are minimal.

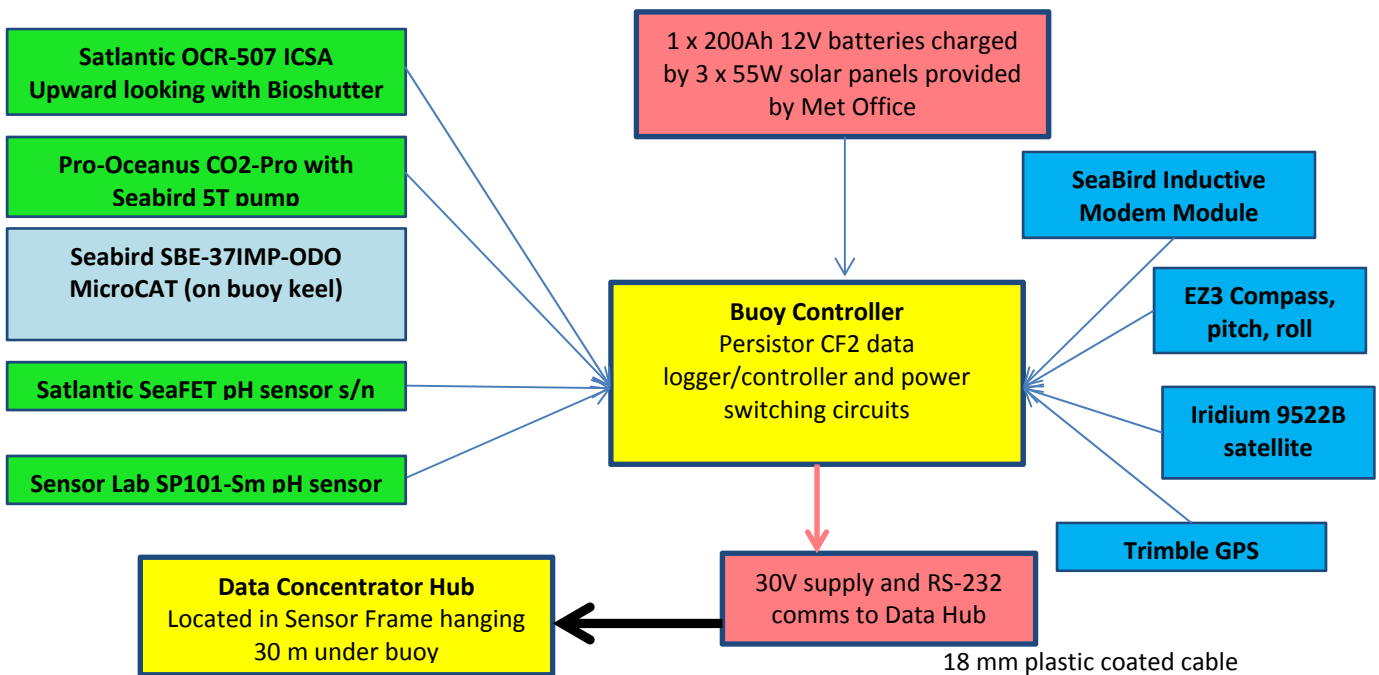


Figure 6 -Telemetry Unit Block Diagram

There is a change in the rs232 component (MAX3244) connecting to the Pro-Oceanus sensors. The change consisted in grounding the auto-shutdown to stop it from going to sleep mode. In fact, the new loggers of these sensors also have an auto-shutdown which prevented from waking up when both sides were in sleep simultaneously. The increase of the power consumption by doing this change is very low. The MAX3244 consumes at most 1mA in idle mode when the auto-shutdown is disabled. Since the data hub only works in the buoy battery, this amount is negligible and does not compromise the system. On the other hand, it is critical that the data from the CO2 and GTD sensors are transmitted to the server to get real-time CO2 and pressure data.

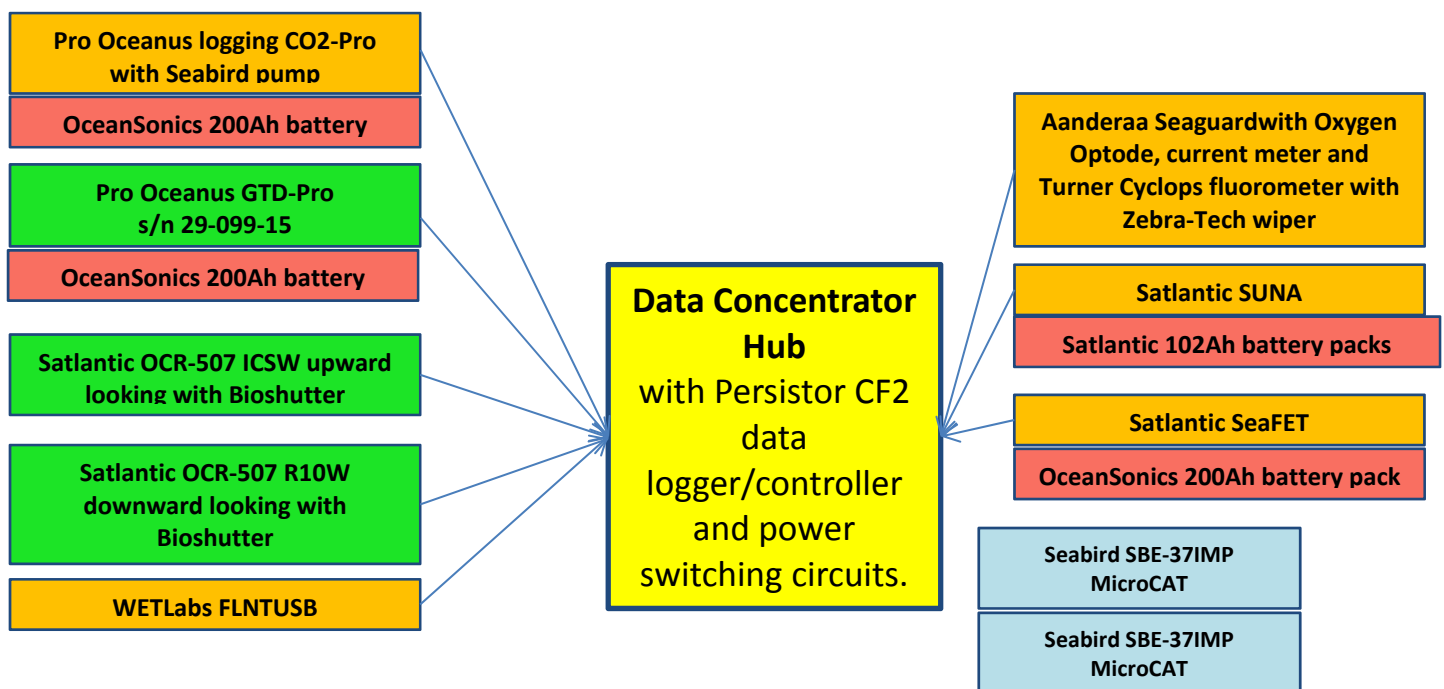


Figure 7 - Hub Block Diagram

There were several changes in the software side: sensor setup through data hub and SBD restart of the system. The first change does not affect how the sensors operate during deployment but facilitates testing, configuring sensors and checks before deployment. It is a step forward towards interacting remotely with the sensors and changing their internal configuration if needed. At the moment, the new implementation allows interacting with sensors through the data hub or telemetry units as it was performed in a regular terminal when the computer is connected directly to the sensor. Only configurations that happen via command lines are possible because the units only allow redirecting the characters that are transmitted from both sides. Especial characters are also possible following the conventions that are shown in the menu of the terminal of the units.

The second change was done to smooth the restart of the data hub or the complete observatory. The previous implementation only requested the CF2 Persistor to restart. We believe this could be a potential reason why the observatory did not restarted properly during the deployment 2014-2015. Another potential factor for that failure is the peak currents that are described in the cruise report of 2015 deployment. It is possible that the real reason is a combination of these two problems. The new software implementation shuts down the power to the sensors and then restarts the microcontroller. If a complete restart of the observatory is requested, the Iridium unit will wait until the data hub is ready for restarting, cut its power and the power of the sensors on the buoy and then restart.

9.2 Deployment and initial performance

The PAP#1 deployment commenced at 10:00 on 18th April 2017 and proceeded smoothly until 12:00. Data telemetered to NOC from the buoy was accessed via FTP using the ship's Internet connection and indicated all the sensors were functioning. Once the frame was in the water, email commands were sent to switch on the Data Hub, the Satlantic OCR irradiance sensors, the CO2 and Sensor Lab pH sensor on the keel. The sampling regimes of these sensors may be altered by sending further email commands. The default sampling regime is shown in Table 1.

Sensor	Serial Number	Intervals (hours)	Minutes after hour
BUOY			
Pro-Oceanus CO2-Pro	29-097-45	12	00
SeaBird SBE-37-ODO-IMP MicroCAT	9030	0.5	0
Satlantic OCR-507 ICSA (buoy) with bioshutter	226	0.5	17
Satlantic SeaFET pH	63	0.5	27
Sensor Lab SP101-Sm pH sensor	Loan	3	26
FRAME			
SeaBird SBE-37-ODO-IMP MicroCAT	10535	0.5	0
SeaBird SBE-37-ODO-IMP MicroCAT	13397	0.5	0
WETLabs FLNTUSB Fluorometer	3050	4	0
Satlantic SUNA Nitrate sensor	745	1	20

Satlantic SeaFET pH sensor	257	0.5	23
Aanderaa 4430H Seaguard	1614	1	30
Aanderaa 4330 optode in Seaguard	2001	1	30
Turner Cyclops Fluorometer in Seaguard (4808 Chlorophyll??)	2103960	1	30
ZebraTech Wiper for Cyclops	NA	6	0
Satlantic OCR-507 ICSW irradiance with Bioshutter	287	0.5	17
Satlantic OCR-507 R10W radiance with bioshutter	95	0.5	17
Pro-Oceanus Logging CO2-Pro	33-200-45	12	59
Pro-Oceanus GTD-Pro	33-152-16	6	56
WETLabs CYCL-P Phosphate Analyser	164	6	40

Table 1 - Sensor Configuration for deployment 2017-2018

Power to the various sensors was also changed when possible to use the battery of the power and save external batteries for the end of the deployment in case of failure of the buoy power. Power from the buoy was switched on for the Wetlabs fluorometer, the Seaguard and the Wetlabs PO4 sensor. The Iridium and SBD communication regimes were kept to 1 hour along the entire cruise to keep a close look to the data and the messages. Unfortunately, at this time, the IT infrastructure at NOC, including the access to the Samba drive was having technical problems. This does not seem to have implications in the data because it is recorded in the local drive of the Iridium server. However, it was an issue for monitoring the status of the observatory. In fact, because of the problems writing in disk, the data files were often corrupted or empty. The SBD emails indicated during those periods of no information that the observatory was operational. We noticed through the SBD emails that the data hub restarted once after deployment. It is not possible to know at the moment the reason for that failure. Possible reasons would be corruption of the memory of the compact flash card or a peak current from one of the sensors or the buoy. It is also possible that the failure came from the buoy that stopped the power to the data hub. Although it does not seem critical at the moment, it is definitely an issue that we should keep an eye on during the operations.

Figure 8 illustrates the status of the observatory and some of the parameters during the first days of deployment. We observe the same patterns as in the previous years, which imply that the observatory

is progressing as expected. There is a periodic behaviour coming that depends on the daily recharge of the solar panels and the schedule of the sensor measurements.

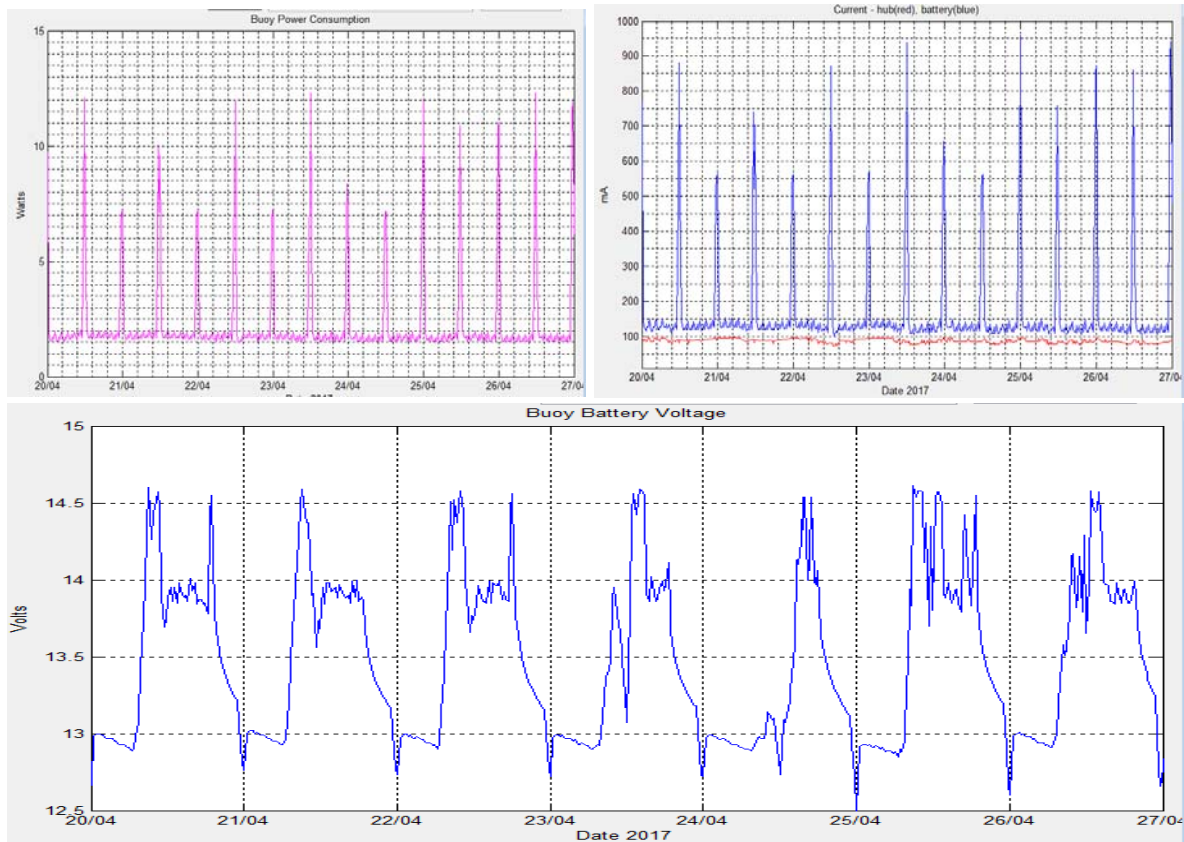


Figure 8 (preceding page) - Measurements first days of deployment. Top left: power consumption of the buoy, top right: current consumption of buoy and data hub, bottom: voltage of buoy batteries.

10 Deployed PAP#1 Sensors

10.1 Aanderaa Seaguard s/n1614

A RCM Seaguard (4420 S/N 685) with Oxygen optode (Aanderaa 4330, S/N 2001) and fluorometer (Turner cyclops, S/N 2103960) were prepared for deployment as part of the PAP#1 sensor frame.

Initial set-up and preliminary checks in the lab and whilst on board showed the Seaguard to be in proper working order and correctly communicating with the central Hub of PAP#1.

10.1.1 Pre-deployment calibration of Seaguard

The Seaguard was placed on a CTD cast (station number 001) to 100 m at 8:30 on the 16th of April, Figure 9. Waters were collected from Niskin bottles and later analysed through Winkler titration for Oxygen to calibrate the Aanderaa optode. The Turner Cyclops fluorometer was also calibrated against water samples that were analysed by a lab based Turner Trilogy unit. The RCM was not tested and the serial output was disabled to conserve battery life.



Figure 9 - Pre-deployment calibration CTD with Seaguard in place of one of the 20 L Niskin bottles, please note the Turner Cyclops fluorometer mounted on the top bar facing upwards out of the CTD rosette.

The oxygen data from the Seaguard was corrected for pressure and salinity using the equations provided in the optode manual and the depth and salinity readings from the CTD graphs, the temperature data was taken from the optode as it was closest to the sensing membrane.

The temperature, pressure and salinity corrected oxygen data was then compared to the levels read from Winkler. The result of this comparison is the calibration presented in Figure 10 and Figure 11. The Seaguard data has a continuous offset and provides lower oxygen values likely as it assumes a salinity of zero and so factory calibration equations have to be applied.

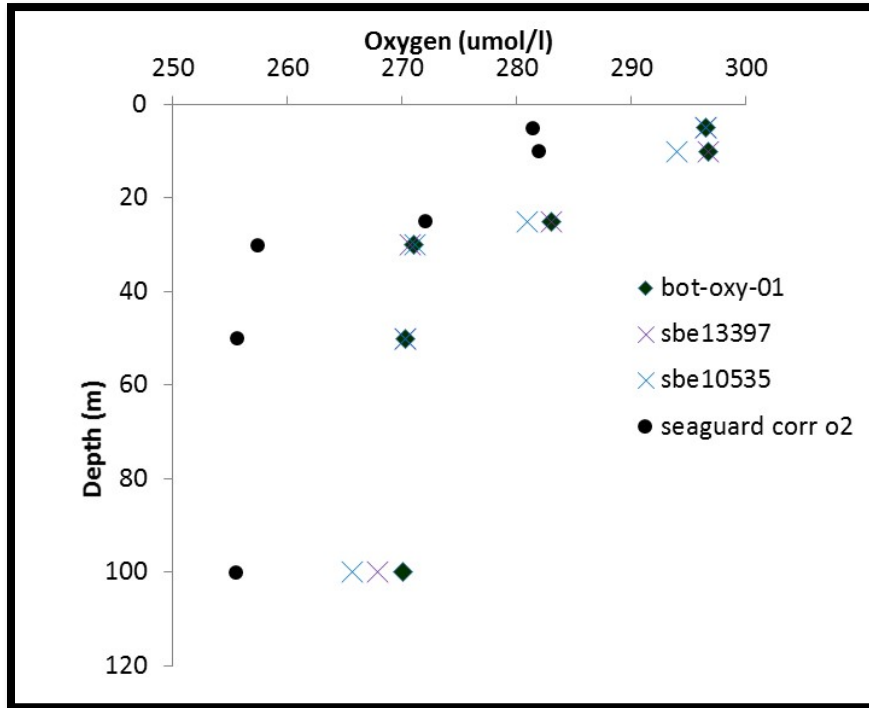


Figure 10 - Oxygen profiles from the pre-deployment calibration dip of the bottle, Seabird and Seaguard data.

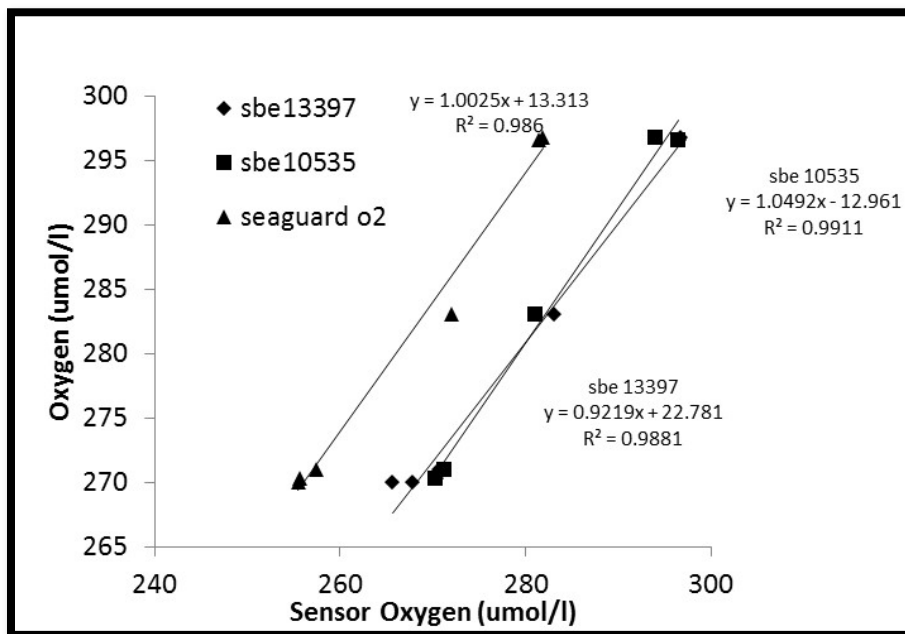


Figure 11 - Calibration plots of Seabird and Seaguard Oxygen data with the bottle Oxygen measured using the Winkler method. All had strong relationships with R2 values of >0.98.

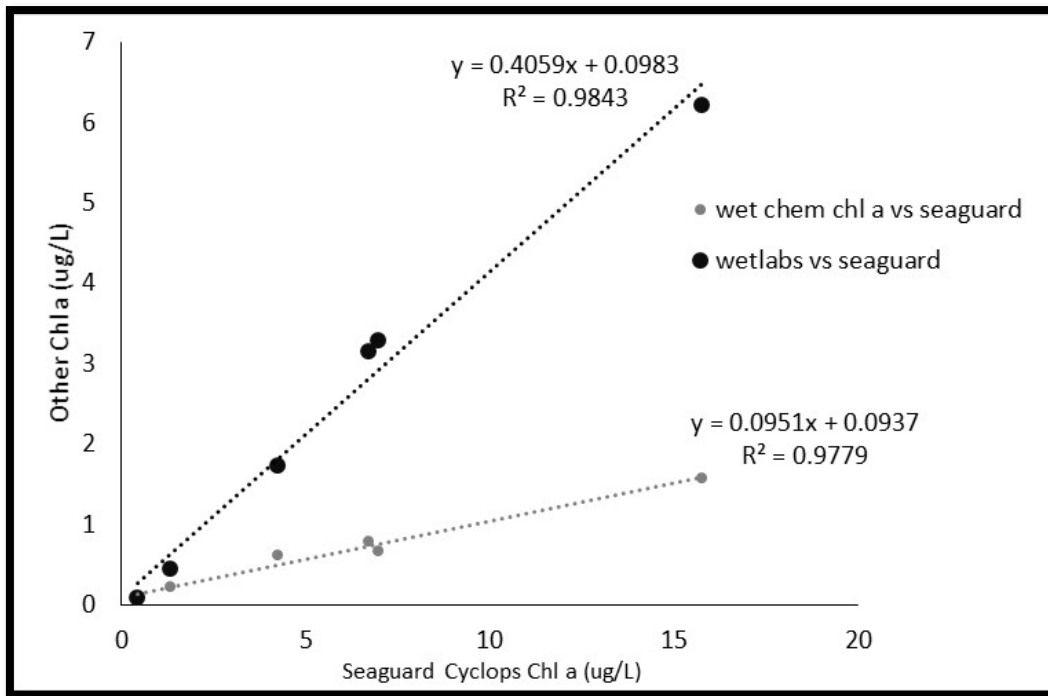


Figure 12 - Chlorophyll a calibration plot of the Seaguard Turner Cyclops fluorometer against the wet chemistry chlorophyll from Niskin bottles and the Wetlabs chlorophyll measurements.

10.1.2 Seaguard and ZebraTech



Figure 13 - The Seaguard in the sensor frame on the day of deployment (18/04/17) with the cap still on the optode to keep it moist (removed before deployment). The clamps on top were secured to keep the Seaguard in place.

The Seaguard was set-up and secured in its pressure housing. The unit was then integrated into the sensor frame, Figure 13. The unit was armed to start operating before deployment to ensure correct communication to the Hub, 10:30 17/04/2017. The scheduling for deployment was to perform a measurement every hour on the half hour, so as to spread inputs to the Hub.

The Cyclops Turner fluorometer was mounted in the ZebraTech wiper and set to activate every 6 hrs, it was started at 08:58 on the 17/04/2017. Having the wiper activate near the hour meant that there was the minimum chance that a wipe could happen at the same time as a measurement by the fluorometer, although the wiper time would have to drift well beyond specification for this to be a problem. The wiper was checked 6 hours later and correctly performed a wipe.



Figure 14 - The Seaguard location in the sensor frame with the zebra tech wiper and battery pack next to the Turner cyclops fluorometer.

10.2 SUNA Nitrate Sensor (S/N: 745)

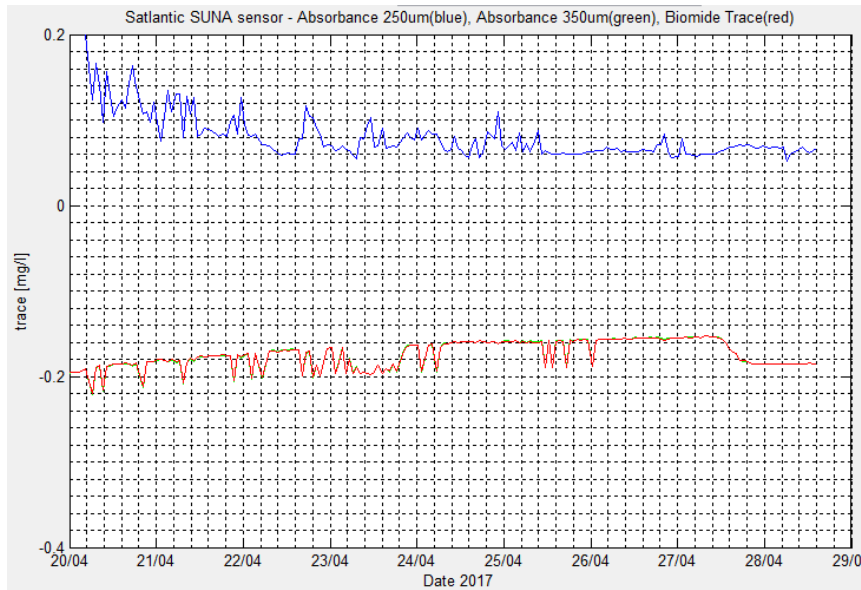
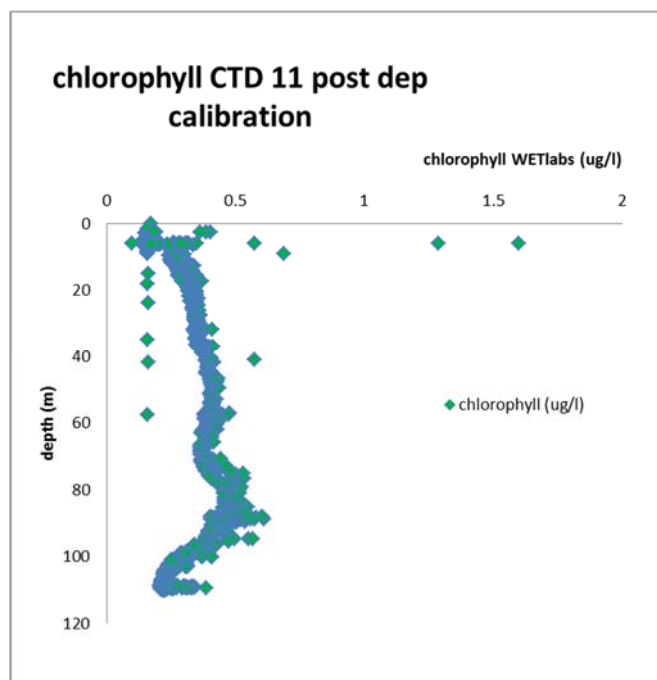


Figure 15 - Absorbance and biomide measurements during first days of deployment

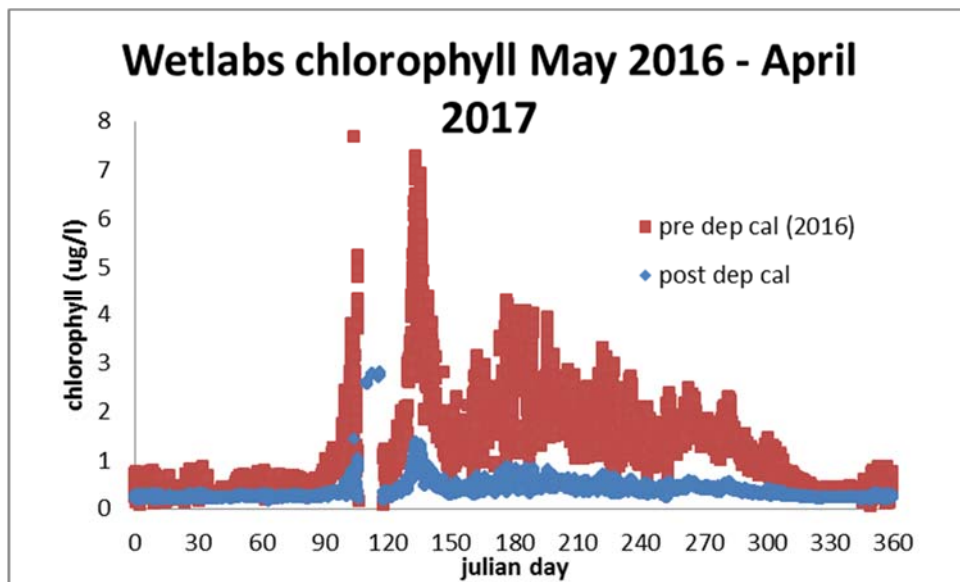
10.3 WETLabs Fluorometer

The wetlabs fluorometer serial number 269 was deployed on DY050 and was due to start telemetering data on 28/04/16. Although the data was not telemetered back the instrument successfully recorded chlorophyll data throughout the deployment.

On recovery, the fluorometer was cleaned and photographed, it had some biofouling, but otherwise in very good condition. It was calibrated on CTD11 (DY077-058).

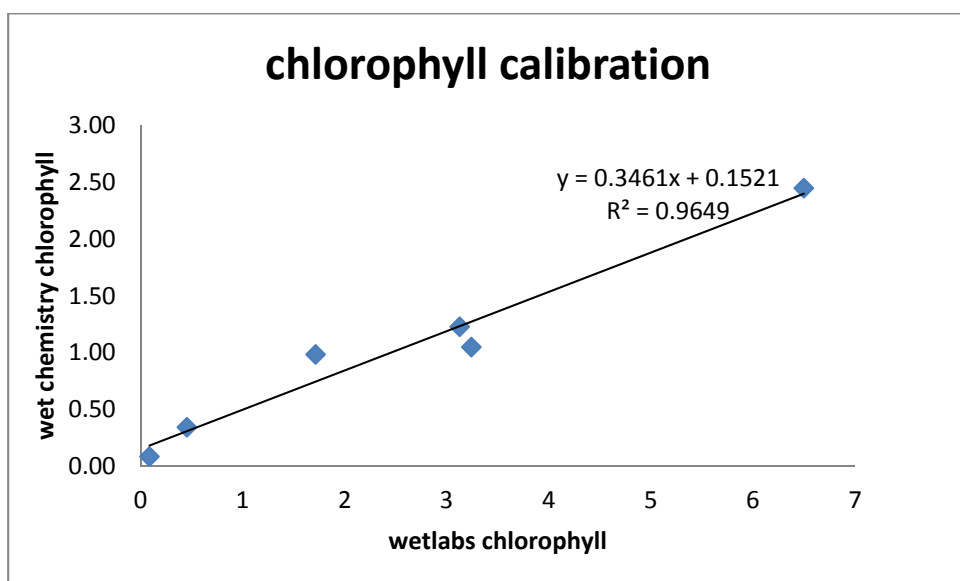


The calibration was applied to the data recovered from the deployments for the whole year. Below the graph shows the corrected chlorophyll from both the pre deployment calibration and the post deployment calibration. The pre deployment calibration gives numbers that are more expected for the PAP-SO so will not be replaced by the post dep cal.

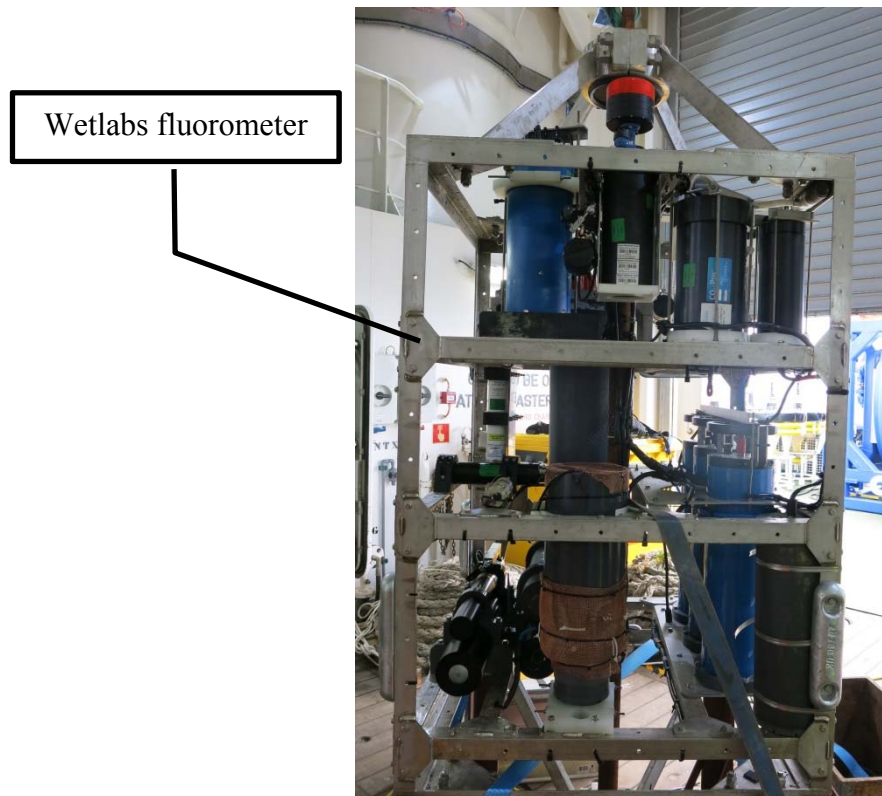


Wetlabs Sensor 3050 deployed

The wetlabs 350 was bench tested prior to embarkation and was further calibrated by deployment on CTD 1. The chlorophyll performed reasonably well and the backscatter was recorded too. The niskin bottles were sampled and the filters were analysed on board on a bench top Triology fluorometer (NOC id- black 2) from Turner. Subsequent to the cruise it was found the wrong calibration had been used for the benchtop fluorometer. The results below have been corrected.



The instrument was positioned in the frame so the cone sample area would not be compromised by the framework, see picture below.



10.4 Sea-Bird SBE 37 MicroCATs

The SBE sensors s/n 10535, 9030 and 13397 were attached to the CTD and calibrated down to 100m with sampling intervals of 10s. The three sensors are SBO measuring oxygen and were serviced prior to the cruise. We normally deploy 2 oxygen and 1 SBE MicroCAT but because last year SBE 37-ODO s/n 9030 sensor failed to measure prior to deployment we replaced it with the SBE 37-IMP s/n 9469 MicroCAT. Therefore, after servicing this year we had 3 SBO available.

Two of the Sea-Bird SBE 37-ODO (s/n 10315 and 13397) were attached to the frame and set to sample temperature, pressure, conductivity and oxygen concentration every 30 minutes. We clamped the SBE 37-ODO s/n 9030 on the keel and set it up with the same configuration. The three sensors were characterized at sea in a shallow CTD at 100m which is the maximum depth rated for the 9030 sensor. The oxygen measurements and calibration parameters are shown in Figure 10 and Figure 11. The 9030 sensor had a broken piece in the inductive communication. This piece is a ceramic half ring that allows the measurement of the current through the cable. Although I found a replacement for it I

forgot to add it before deployment. Therefore, the sensor is only logging internally and no real time data provided to a remote server since the telemetry system cannot access it.

10.5 Pro-Oceanus dissolved gas sensors

10.5.1 CO₂ sensor on the buoy

A non-logging CO₂-Pro CO₂ sensor (s/n 29-097-45) was attached to the buoy keel and is powered and controlled by the buoy Telemetry Unit. It was serviced in 2016 after its recovery on April. This sensor is powered from the buoy and is planned to be switched on every 12 hours (at 11:20 and 23:30). The configuration can be changed remotely via SBD emails. Auto Zero Point Calibrations (AZPC) is done every time it is powered on. Figure 16 and Figure 17 show the initial performance of the CO₂ sensors after deployment. As usual, the values of the CO₂ sensor in the keel scatters due to the fact that the samples are taken during the end of the warming up period of the sensor. In contrast, the CO₂ in the frame indicates when the warming up of the sensor is done. Figure 17 shows that the auto-zeros of the two sensors are consistent.

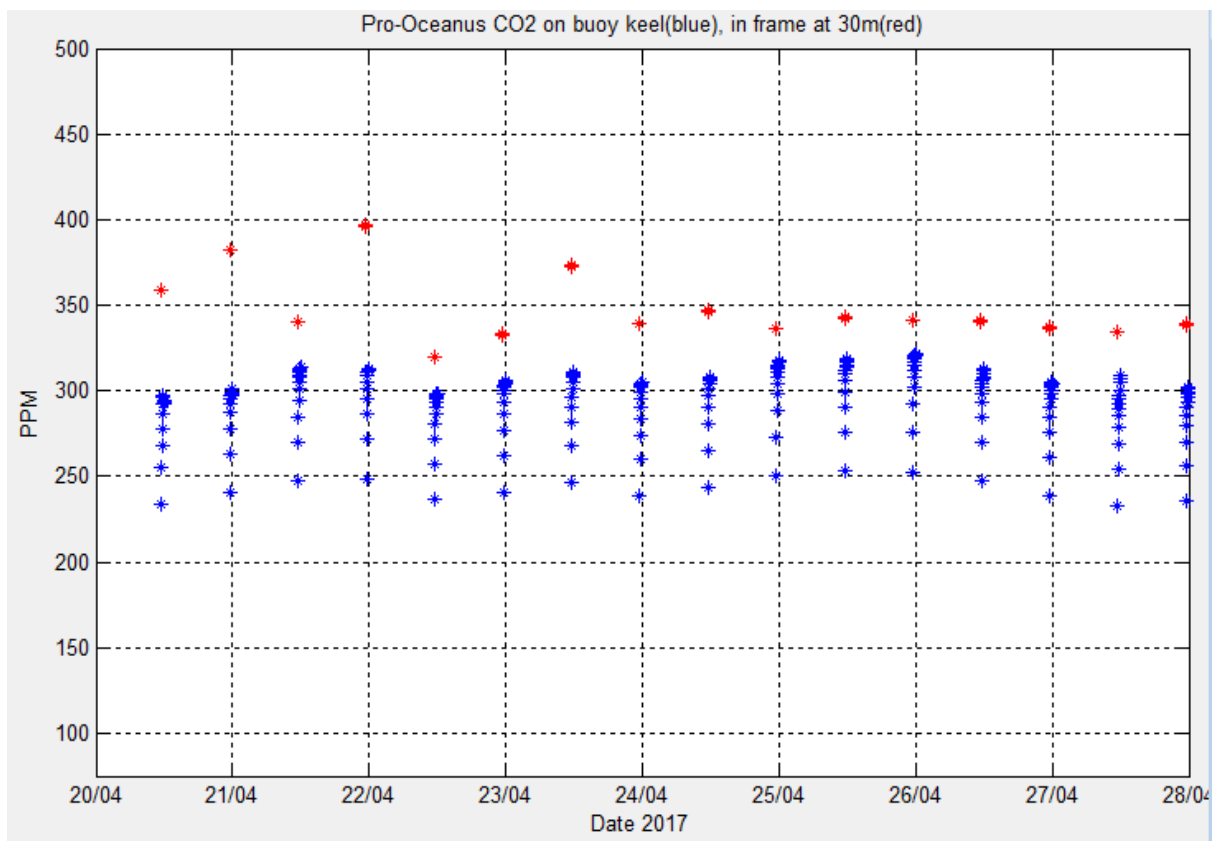


Figure 16 - CO₂ measurements during the first days of deployment

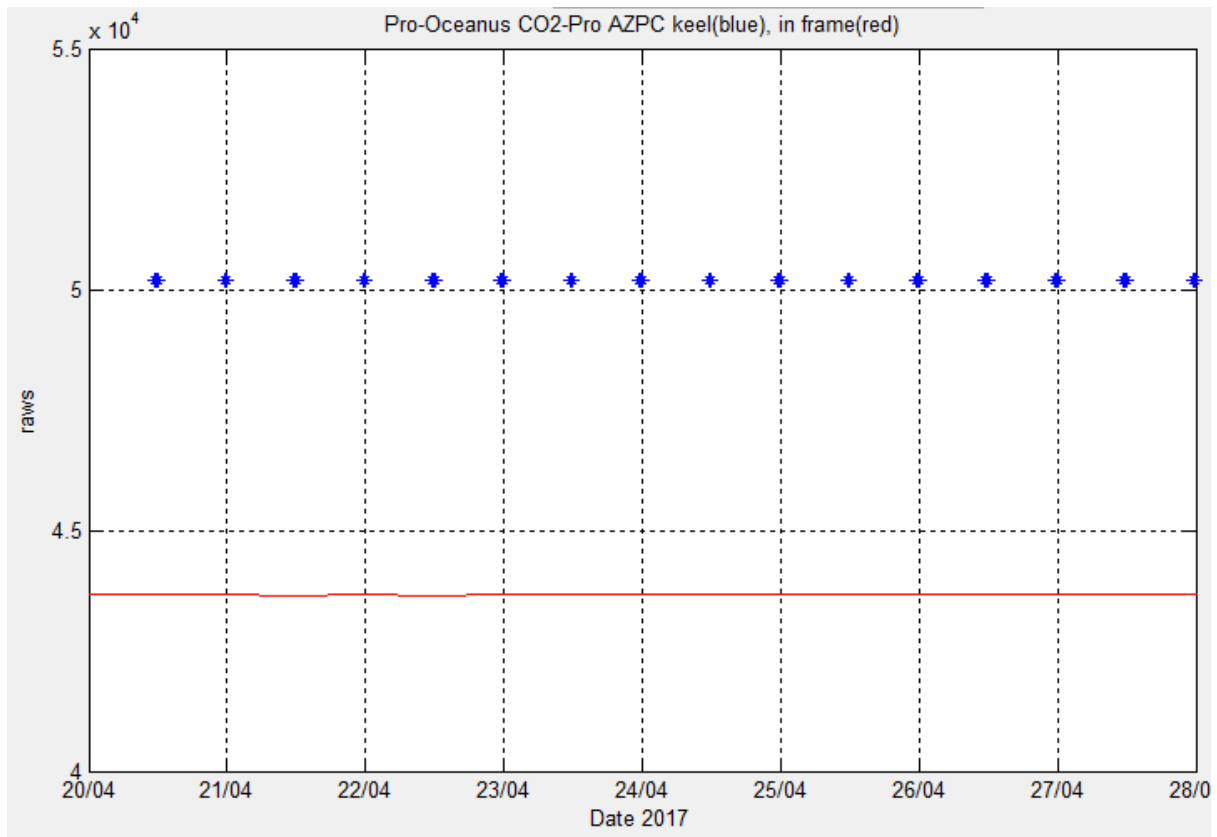


Figure 17 - CO2 zeroing measurements during the first days of deployment

10.5.2 CO2 sensor on the frame

A self-logging CO2-Pro (s/n 33-200-45) was attached to the sensor frame and was configured to sample every 12 hours at midnight and noon producing 4 samples per record and performing an AZPC every 4 sampling sessions. The real time clock battery was fully charged shortly before deployment. This sensor is powered by a 168Ah OceanSonics battery providing a voltage of approximately 14.4V and 336Ah.

The ascarite CO2 absorbent in this sensor was replaced when serviced after the recovery of the sensor on July. The data logger of this sensor was changed shortly before the cruise by a new data logger provided by Pro-Oceanus. The previous data logger did not allow changing the sampling time. The Pro-Oceanus sensors with the tubular interface are slower at depth. By the time the sensor warms up and takes a zero, there was not enough time left in the 20 minute sampling cycle to fully equilibrate. This created lower values during the samples with automatic zeroing due to the lack of complete equilibration. The new logger can be configured to a range of sampling times. However, it was not able to wake up the MAX3244 component on the electronics of the data hub. As explained in section 1, the electronics in the data hub was modified to avoid the MAX3244 to shutdown allowing the data to be recorded and transmitted as shown in *Figure 16*.

10.5.3 GTD sensor on the frame

A GTD-Pro gas tension sensor (s/n 33-152-16) was also attached to the sensor frame. Pro-Oceanus upgraded the sensor to include a logger. This will allow to record data internally in the sensor. In order to allow the sensor to run autonomously in case of failure of the data hub, we powered it by a 168Ah OceanSonics battery providing a voltage of approximately 14.4V and 336Ah. The sensor is configured to take measurements every 6 hours from midnight. The values of the pressure measurements of the GTD as well as the 2 CO₂ sensors are shown in *Figure 18*.

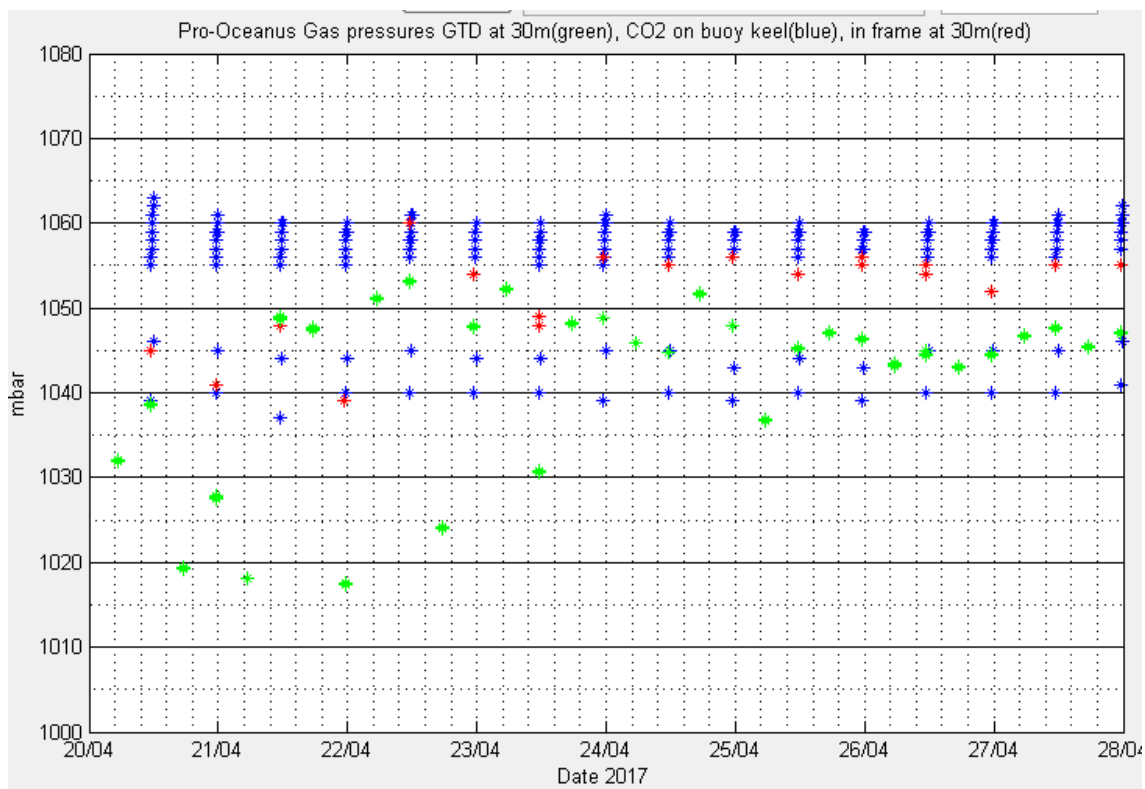


Figure 18 - Pressure measurements during the first days of deployment from the GTD and CO₂ sensors in frame and keel

10.6 pH SensLab sensors

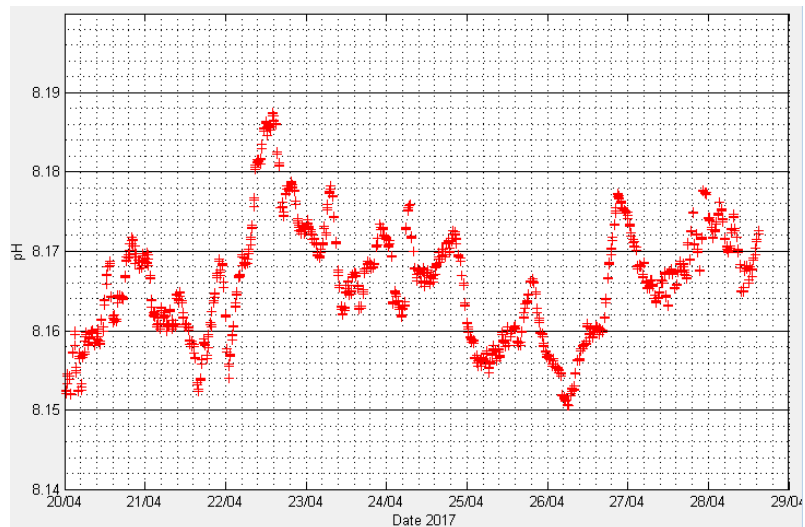
The set of pH sensors at PAP#1 deployment include a Sensor Lab SP101-Sm pH sensor on loan from Melchor González Dávila at ULPGC on Gran Canaria along with two Satlantic SeaFET pH sensors (s/n 63 and 257). The SP101 was calibrated before being received by NOC and checked and serviced in Southampton before the cruise began by Melchor. However, there were a lot of failures in the sensor during the tests at NOC and on board. The sensor has troubles turning on after it is power and it randomly works or fail. It is currently not switching on at the moment. It is programmed to turn on every 3 hours but everything seems to indicate that it will not be operational during this deployment.

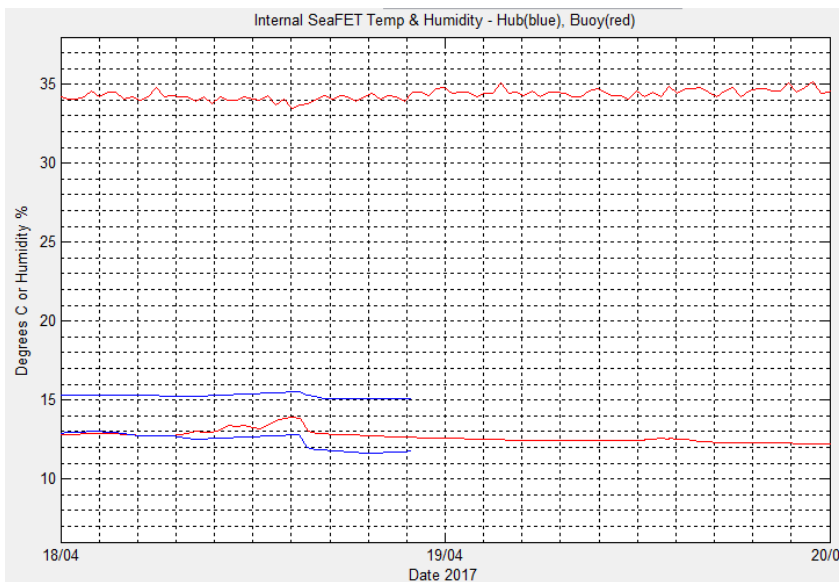
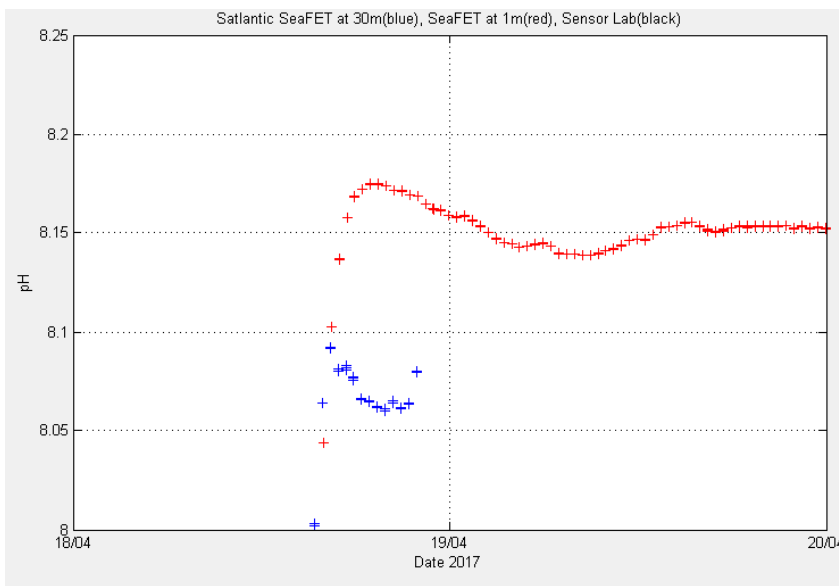
10.7 SeaFET pH sensors

10.7.1 Deployment of SeaFETs on the sensor frame and the buoy.

The SeaFET sensors are programmed to take samples every 30min. They are connected to internal batteries and external batteries. At the frame, the SeaFET 257 is connected to an Ocean Sonics battery with 206Ah and at the buoy the SeaFET 63 is also powered by an OceanSonics battery at the keel with 206Ah. This battery is one of the old set that was recovered in 2016. A distinctive characteristic of the SeaFET is that it requires an uninterrupted and isolated source of power to keep the sensing element conditioned and the battery pack is split into two packs, the main pack with 8 batteries (12V) and the isolated pack with 4 batteries (6V). The 'Main battery pack' and the external batteries are used to power the instrument control electronics when the instrument is in active mode. They can also be powered by the buoy batteries through the telemetry system or the data hub.

On the frame, SeaFET was set up to sample in periodic mode with a sampling interval of 30 min and 1380 sec offset (23 min past the hour), producing 3 Frames per burst (output of 3 samples, each is an average of 10 readings) and creating a DAILY log ASCII file. On the buoy, SeaFET was set up to sample in PERIODIC mode with a sampling interval of 30 min and 1620 sec offset (27 min past the hour), producing 3 Frames per burst (output of 3 samples, each is an average of 10 readings) and creating a DAILY log ASCII file. Note that the sampling regimes cannot be changed remotely.



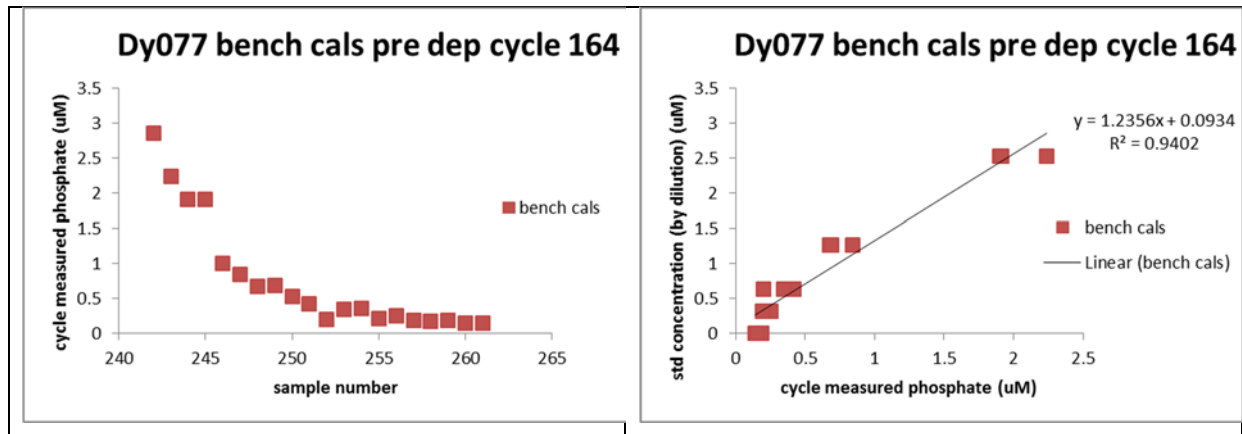


The SeaFET in the keel is recording data as shown in the figure. Unfortunately, the SeaFET at the frame failed a few hours after deployment. In fact, the measurements of the two sensors follow the same path until the point when the one in the frame failed. The measurement of the SeaFET in the frame started dropping while the other one kept rising to the sea water values. Then, it stopped. It is hard to interpret the cause of the failure. Although, a water leak seems likely due to the behaviour of the data, the data does not show any variation of the internal humidity (see Figures) or a peak in the current or power.

10.8 Cycle Phosphate Sensor 164 for Deployment

Corinne Pebody

Cycle sensor serial number 164 was calibrated at NOC prior to sailing, then tested on the frame prior to sailing. On board it was calibrated against standards (sample preserved for accurate measurement back at NOC) to provide a calibration for deployment.



The first graph shows the measurement against a sequence of four replicates of each of four concentrations and a MilliQ zero. The graph shows that the cycle has a slight hangover from the previous sample affecting the first and possibly the second measurement of each set of four. To avoid complications from this, only the second, third and fourth measurements were used for the calibration. This took the r^2 to 0.94 (second graph). The equation ($y=1.2356X+0.0934$) can be applied at NOC as the data is received.

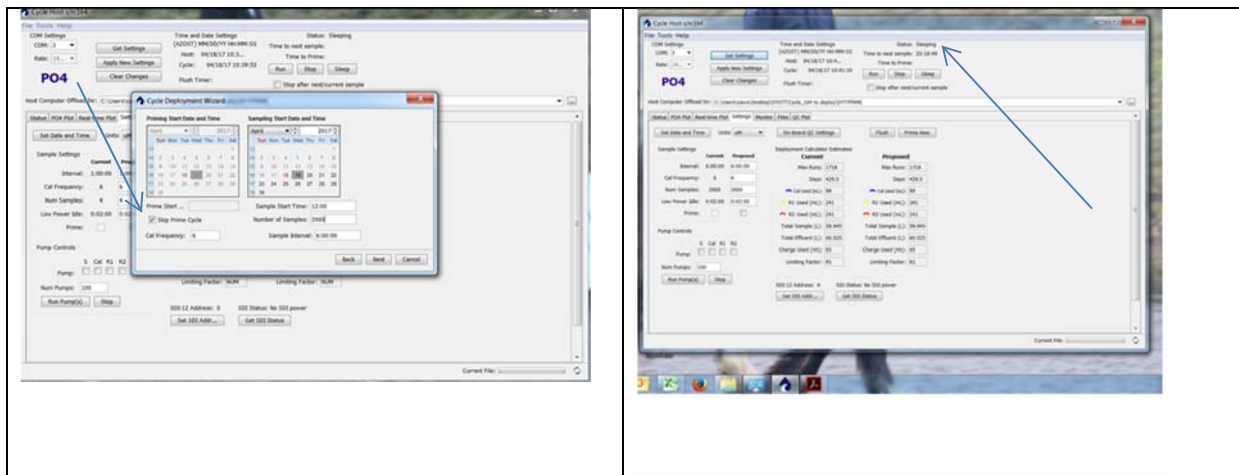
Once the bench cals were complete, the standard and reagents were replaced with new unused cartridges. The instrument was re-tested on the frame, but failed to get past the initial priming sequence. The instrument was removed checked and reprogrammed to run over night and checked in the morning. It failed to run again. It was bench tested again and the cartridges checked. It ran a prime and a sample successfully. Next step was to disconnect from power and coms for ten minutes to simulate being switched off and transferred to the frame. It sampled successfully after this test.

After much useful discussion with Rob Brown and Miguel and with little time left two theories were acted upon.

First to skip the prime step. This was because this stage has a big power draw, bigger even than sampling (when measured by Jon Campbell back at NOC (from memory)). This would avoid any power draw overloading the batteries/hub and preventing the instrument from even getting to the sampling stage. This theory was supported by the feedback from wetlabs on the failed instrument recovered on DY050 in 2016. When serviced, the memory had recorded tens of low power messages

which may have resulted from the instrument trying and failing to start. To avoid this issue the skip prime cycle was ticked, see print screen below.

The second theory was from a wetlabs tech note (120607-1) describing a firmware bug whereby if the instrument is disconnected in RUN or IDLE states, it turns off but wakes up under UPS power and transmits the ‘low power fault’ message. If power is not reapplied (as it wouldn’t be for the time when the Cycle was on the frame waiting to go over-board, then waiting to switch on) this could result in loss of system settings. This fault would also generate the ‘low power’ messages already referred to. The ‘cure’ is to ensure that the cycle is switched off when in SLEEP mode. This was applied, see print screen below.



The Cycle was scheduled to start sampling at 12:00 on 19/04/17. We have not received any communication from it to date.

10.9 Satlantic OCR-507 Irradiance sensors

A Satlantic OCR-507 ICSA irradiance sensor (s/n 226) was fitted to the buoy mast and is controlled by the Telemetry Unit. The clamp was reused from the observatory that we recovered this year.

The Data Hub controls an OCR-507 ICSW upward-looking irradiance sensor (s/n 287) and an OCR-507 R10W downward-looking radiance sensor (s/n 95). Sensors s/n 226, 287 and 113 were sent to servicing mid-2016. Unfortunately, the sensor 113 was not working when we first tested it in February 2017 and the company was not able to provide the repaired sensor or a replacement on time. We replaced it with the one that we recovered from previous year deployment that was in a good condition. All 3 sensors were commanded to sample every 30 minutes at the same time so that their data are coincident. The sampling intervals can be changed remotely using SBD commands.

11 PAP#1 Recovered Data Hub and Telemetry Systems

The recovered PAP Observatory system was deployed on 28th April 2016 on *Discovery* cruise DY050 and the PAP0003 system was fully operational until its recovery. The buoy and sensor frame were recovered without difficulty on the morning of 15th April 2017. The mooring rope was disconnected from the bottom of the sensor frame and attached to a large buoy which was then released. This allowed the vessel to continue with other work until the system was finally re-attached to the mooring and deployed on 18th April. It was initially planned to swap the entire mooring but one of the segments of the mooring was found missing when they were putting together the equipment during mobilization. Therefore, the mooring was reassessed, repaired and reused for this deployment.

Sensor	Performance	Recommendations and Actions
Telemetry	Did not work because of the lack of power.	Need assessment at NOC.
Pro-Oceanus CO2-Pro	Did not work because of the lack of power.	Assess need of servicing.
SeaBird SBE-37-ODO-IMP MicroCAT	Worked along deployment.	Assess need of servicing.
Satlantic OCR-507 ICSA (buoy) with bioshutter	Sensor could not sample due to the lack of power. Clamp was reused in the newly deployed system	Assess need of servicing.
Satlantic SeaFET pH	The sensor was sampling data for most of the deployment. Data was uploaded from sensor.	Servicing.
Sensor Lab SP101-Sm pH sensor	Did not work because of the lack of power.	Return to Melchor

Table 2- Assessment needs for recovered sensors at the buoy

The system was again highly biofouled but we hope that the copper painting this year will fix this problem during the current deployment (see *Figure 19*).



Figure 19 - Recovered system showing biofouling at the buoy and the frame.

The orange cable, the protective hydraulic hosing over the cable and the sensors did not show any obvious damage. We reused the large hose during the deployment this year.

Sensor	Performance	Recommendations and Actions
SeaBird SBE-37IMP MicroCAT	Worked along deployment.	Assess servicing
SeaBird SBE-37IMP MicroCAT	Worked along deployment.	Assess servicing
WETLabs FLNTUSB Fluorometer	Sampling successfully most of the deployment. Data uploaded from sensor.	Assess servicing
Satlantic SUNA Nitrate sensor	Sampling successfully most of the deployment. Data was uploaded from sensor.	Servicing.
Satlantic SeaFET pH sensor	Sampling successfully most of the deployment. Data was uploaded from sensor.	Servicing.
Aanderaa 4430H Seaguard	Missing. Clamp not screwed in the frame.	Need replacement.
Satlantic OCR-507 ICSW irradiance with Bioshutter	Did not work because of the lack of power.	Asses if servicing is needed.

Satlantic OCR-507 R10W radiance with bioshutter	Did not work because of the lack of power. We use it to replace the one that was missing this year because of a bad servicing.	Will use the one that is currently at servicing
Pro-Oceanus Logging CO2-Pro	Connector was broken at deployment and sensor was flooded and destroyed.	Need replacement
Pro-Oceanus GTD-Pro	Did not work because of the lack of power.	Asses if servicing is needed.
WETLabs CYCL-P Phosphate Analyser	Sampling successfully for about 3 months. Data was uploaded from sensor.	Assess if servicing is needed.

Table 3 - Assessment needs for recovered sensors at the frame

11.1 Recovery of the Seaguard (s/n1130)

When the sensor frame was pulled on board the Seaguard (S/N 1130) was missing, along with the battery pack of the zebra tech wiper and the cable connecting it to the hub had sheared, Figure 20, Figure 21 and Figure 22. The growth on the surviving bottom clamp suggests that the sensor has been missing for some time and we can speculate that the top clamps were not secured properly before deployment and the shearing of the cable may have cause the issues with the Hub not communicating after deployment in 2016. As the Hub was not communicating and the Seaguard was lost there is no data to retrieve from the 2016 deployment from the current meter, oxygen optode or fluorometer. A final checklist was created for the sensor frame before deployment and everything was checked thoroughly to try and prevent a similar situation occurring again.



Figure 20 - The slot where the Seaguard (S/N 1130) was initially located. The growth on the inner ring of the bottom clamp suggests it had been lost for some time



Figure 21 - The sheared cable that connected the Seaguard to the Hub



Figure 22 - The brush of the zebra tech wiper. The battery pack had been lost

11.2 Pro-Oceanus Sensors

The CO2 sensor at the keel and the GTD sensor at the frame that were deployed last year did not have an internal logger. Therefore, no measurement was taken by these two sensors. They seemed to be in good working conditions.



Figure 23 - Broken connector of the CO2 sensor at the frame

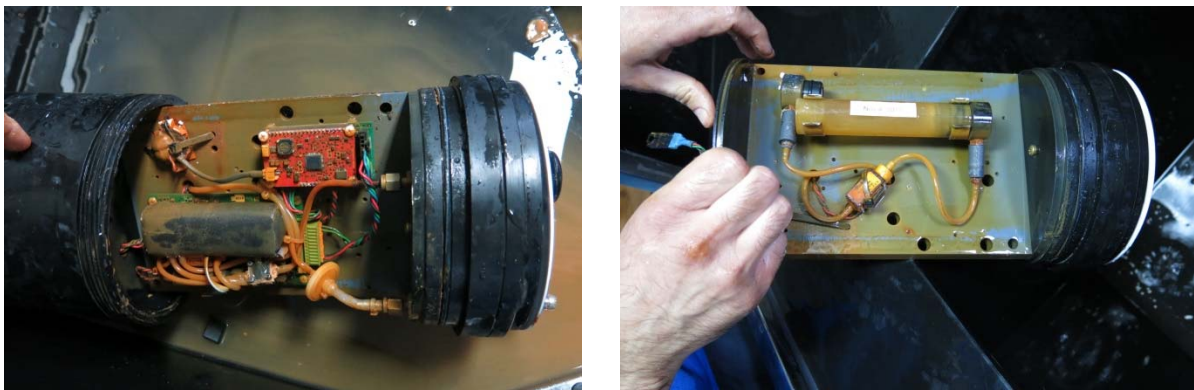


Figure 24 - Flooded sensor logger side (left) and chemical side (right)

The CO2 sensor at the frame had an internal logger and an external battery that would allow it to take measurements despite of the power failure. However, the connector to the sensor was knocked out, probably during the deployment process. In fact, the sensor logged internally the expected samples until deployment. As shown in Figure 23 the connector seemed to be mechanically hit. The most likely reasons are that either it was knocked out during the deployment or that the Seaguard swept it on its way down. As explained in previous section, the Seaguard was not tied correctly to the frame and was missed this year. This likely happened as soon as the frame was in the water and it would be a consistent cause of the broken connector.

11.3 Sea-Bird SBE 37 MicroCATs

Three Microcats were recovered from the 2016-2017 deployment. The Sea-Bird SBE 37-ODO (s/n 10315) was attached to the buoy keel and set to sample temperature, pressure and conductivity every 30 minutes. Sea-Bird sensors SBE 37-ODO (s/n 9469) and SBE 37-IMP (s/n 6915) were attached to the frame. The SBE 37-ODO was set to sample temperature, pressure, conductivity and oxygen concentration every 30 minutes, while the 37-IMP samples temperature, pressure and conductivity every 30 minutes. The sensors recorded the data internally for the entire deployment. They were calibrated after recovery in a shallow CTD down to 100m.

11.4 Satlantic OCR-507 Irradiance sensors

The three OCR sensors that were deployed last year were recovered and in good conditions. A Satlantic OCR-507 ICSA irradiance sensor (s/n 201) was fitted to the buoy mast. The Data Hub controls an OCR-507 ICSW upward-looking irradiance sensor (s/n 200) and an OCR-507 R10W downward-looking radiance sensor (s/n 95). None of the 3 sensors took any measurement because of the failure of the power last year. All sensors were serviced before the deployment and they are paired with a bioshutter to avoid biofouling. The sensor s/n 95 was reused for the 2017-2018 deployment.

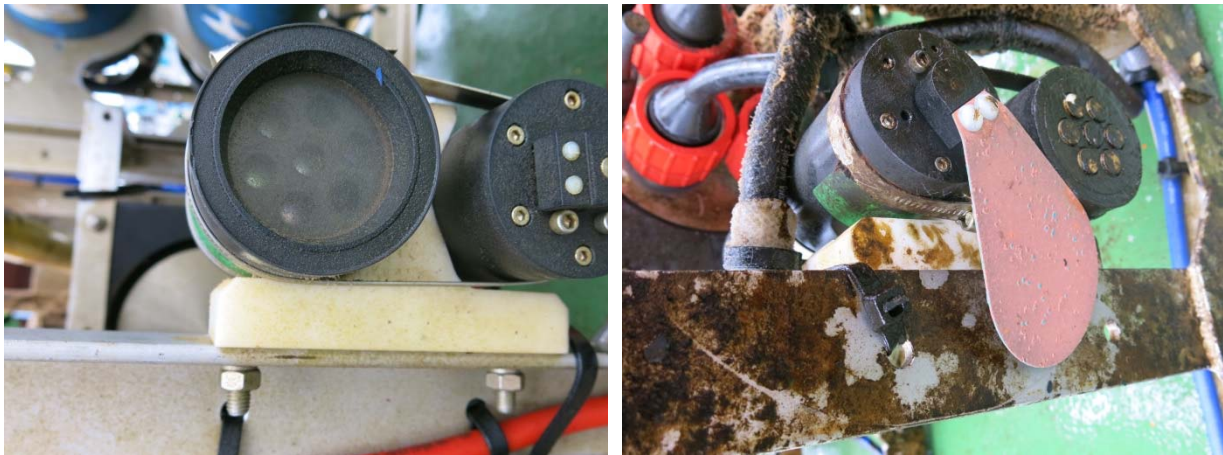
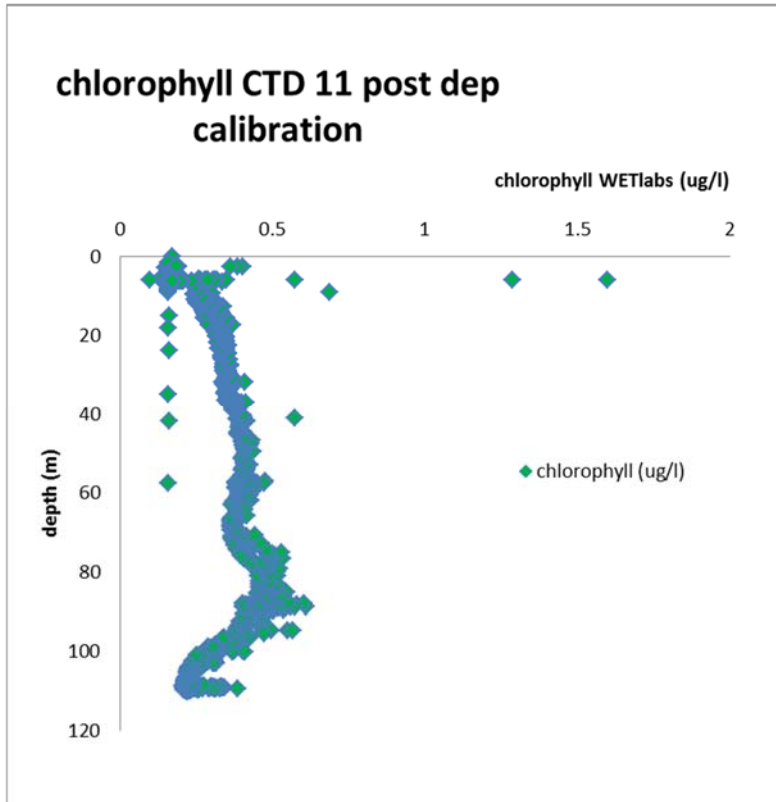


Figure 25 - OCR sensors in the frame after recovery

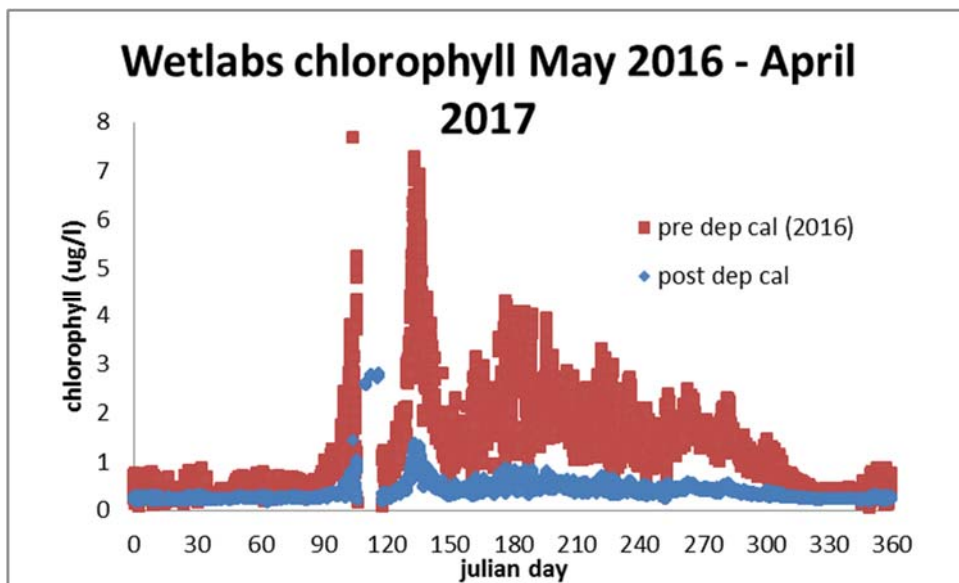
11.5 WETLabs Fluorometer

The wetlabs fluorometer serial number 269 was deployed on DY050 and was due to start telemetering data on 28/04/16. Although the data was not telemetered back the instrument successfully recorded chlorophyll data throughout the deployment.

On recovery, the fluorometer was cleaned and photographed, it had some biofouling, but otherwise in very good condition. It was calibrated on CTD11 (DY077-058).



The calibration was applied to the data recovered from the deployments for the whole year. Below the graph shows the corrected chlorophyll from both the pre deployment calibration and the post deployment calibration. The pre deployment calibration gives numbers that are more expected for the PAP-SO so will not be replaced by the post dep cal.



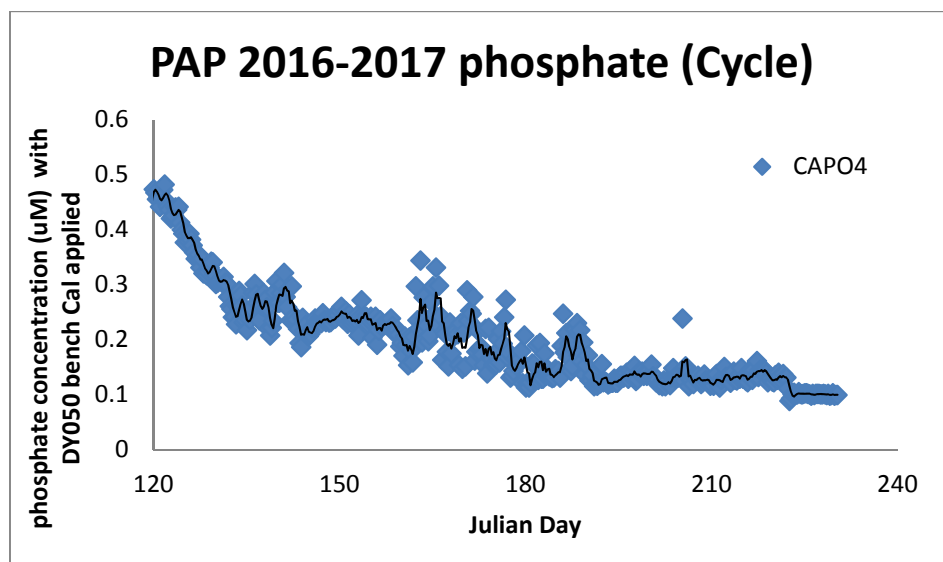
11.6 Cycle Phosphate Sensor 177 recovered

Corinne Pebody

The loaned Cycle sensor serial number 177 was deployed on DY050 and was due and failed to start telemetering data on 28/04/16. The Cycle was programed on deck because of difficulties programming along time ahead of deployment and had been performing well during bench calibrations and on frame tests. However it did not communicate at all since deployment so it was not known whether it was working or not.

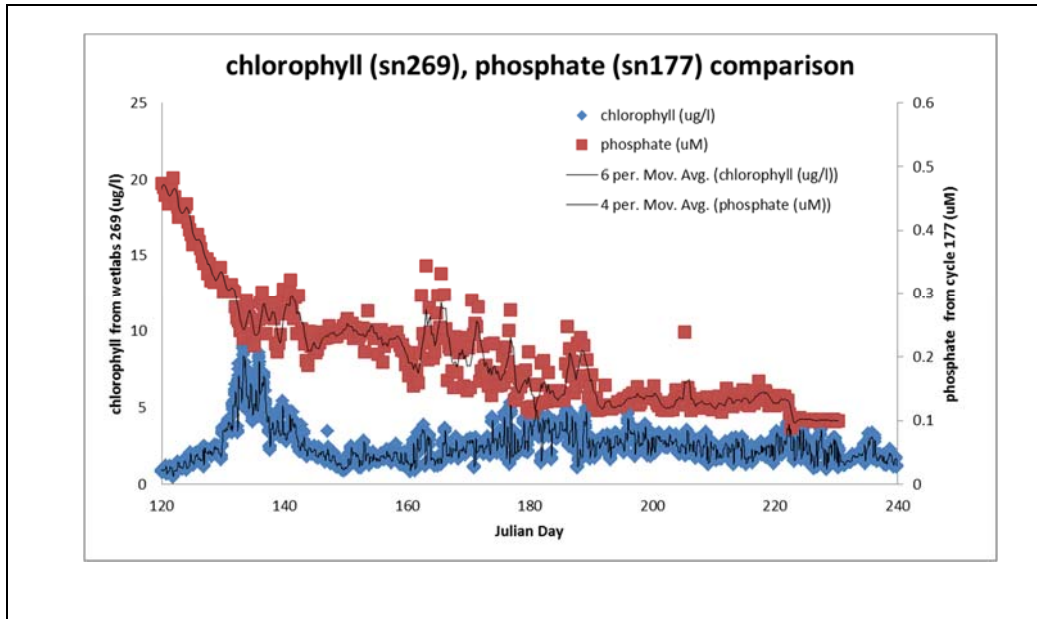
On recovery, the cycle was removed from the frame and photographed, it had significant biofouling, 3 screws missing from casing, 1 part way out, and 1 scrape along the protective housing, but otherwise in very good condition.

The instrument switched on immediately and had over 400 records of sampling events. This was downloaded and calibrated against the bench calibrations ($y=1.0636 X +0.0705$) made on DY050 prior to deployment.

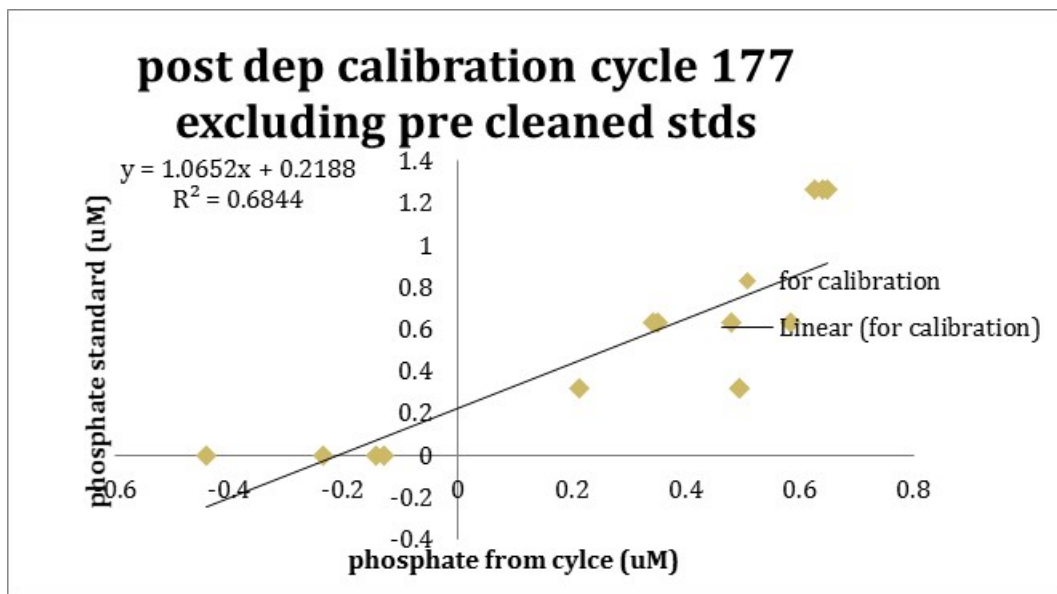


The black line is a four point running average to produce a daily value. The first section shows the phosphate being used at the beginning of the bloom, then steady uptake through the summer with periods of possible remineralisation to produce little peaks. The final tail where the values drop and level off are probably due to the chemical lifespan.

The phosphate marries up well with the chlorophyll values in the graph below.



After recovery the instrument was cleaned and then calibrated using a series of phosphate standards. The standards that were run before the instrument was taken apart and cleaned were rejected.



The equation and r squared had changed considerably over the year.

April 2016	$Y = 1.1116 \times +0.0803$	$R^2 = 0.9819$
April 2017	$Y = 1.0652 \times +0.2188$	$R^2 = 0.6844$

The chemicals are only expected to have a three month life expectancy so it was excellent that they worked so well until August. The graph showing the data for summer 2016 show a drop and then a flat line at the end of the plot, which is probably attributable to wither the chemicals or to battery life.

11.7 Atlantic SUNA Nitrate Sensor (S/N 745)

11.7.1 Pre-deployment calibration

The SUNA nitrate sensor S/N 745 was calibrated in the lab at NOC (02.02.2017) using one point calibration method with a set of nitrate calibration standards (0 μM , 10 μM , 20 μM and 40 μM). The standards were prepared using a nitrate standard stock of 5014.7 μM and artificial sea water (ASW; salinity 40 psu). Performance of the instrument in de-ionised water (DIW) was also checked.

SUNA was also calibrated on board (15.04.2017) in a similar way using blank DIW and low nutrient seawater (LNSW) and 15 μM nitrate standards prepared in both DIW and LNSW.

The exact concentrations of all the calibration solutions will be determined using Nutrient AutoAnalyser at National Oceanography Centre Southampton.

Preliminary calibration results including manufacturer's calibration shown in *Figure 25*.

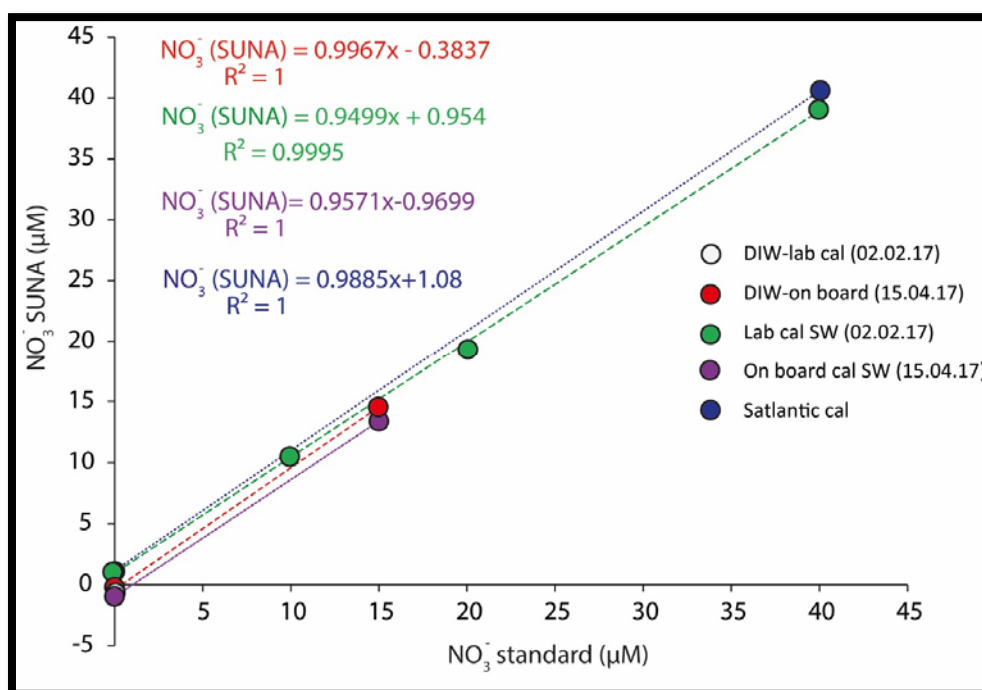


Figure 26: Pre-deployment calibration of SUNA nitrate sensor

11.7.2 Deployment on the sensor frame

On the sensor frame deployed at 30 m (Fig. 26), the SUNA Nitrate sensor was configured to sample in a periodic mode/frame based operation. The sampling interval was set to 1 hour with 1200 sec (20 min) offset past the hour. Within the sampling interval, the acquisition duration was given by the number of frames. For this deployment, the chosen 1 frame operation outputs 1 dark frame then 1 light frame which is the average of 10 samples. This gives an estimated frame rate of 0.1587 frames per second (6.3 sec/frame). The integrated wiper was enabled.



Figure 27: Satlantic SUNA S/N 745 nitrate sensor with integrated wiper ready to be deployed on a sensor frame

11.7.3 SUNA (S/N 698) recovery

SUNA (S/N 698) deployed on a sensor frame during cruise DY050 was successfully recovered on 17.04.2017 (Fig. 27). The connection with the instrument was initially established via USB cable and all collected data and log files were retrieved. A post-recovery calibration test deemed unsuccessful, as SUNA failed to connect to the external power supply. Further, SUNA stopped communicating via the USB cable as well. This might have been caused by the failure of the internal battery of the instrument.



Figure 28: Satlantic SUNA Nitrate sensor recovered from the sensor frame one year after deployment. Biofouling likely biased the nitrate concentration data.

Overall, SUNA collected Nitrate concentration data from 28.04.2016 to 01.02.2017 (Fig. 28).

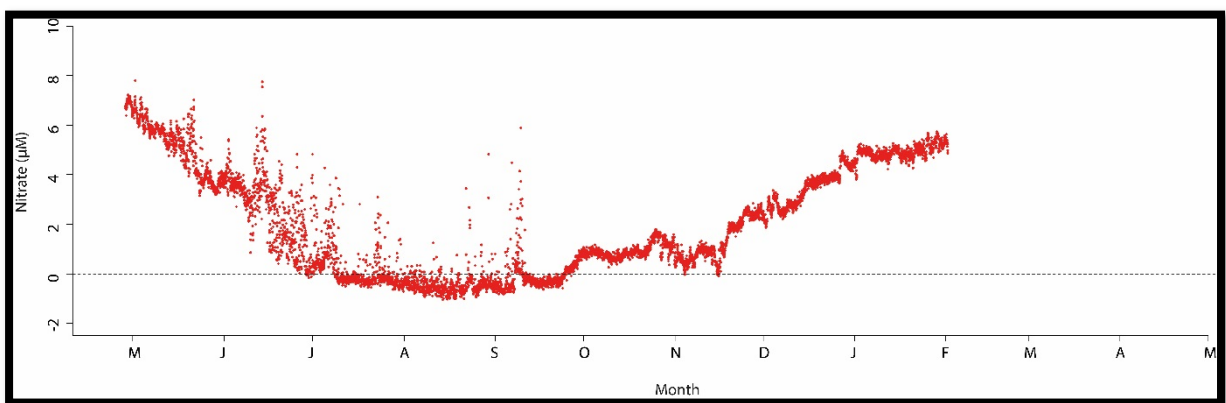


Figure 29: Uncalibrated nitrate concentration data collected by Satlantic SUNA S/N 698 sensor deployed at 30 m below the surface from 28.04.2016 to 17.04.2017.

11.8 Satlantic SeaFETs pH sensors

11.8.1 Pre-deployment calibrations for deployment on a sensor frame and buoy

The SeaFET pH sensors (S/N 257 and 063) were calibrated in the lab at NOC and on-board RRS *Discovery* using a set of Certified Reference Materials (CRMs) of known pH values (Batches 128, 146 and 151). The sensors were sampling in the CONTINUOUS mode during calibration. The sensors were warmed up for approximately 2 hours (to stabilise internal temperature of the sensor) before the steady readings were logged. Temperature was recorded with a thermometer at the beginning and end of the calibration test and the pH of CRM was calculated using CO2Sys_v2.1 macro. The results of the calibration test are summarised in Figure 29 and Table 4.

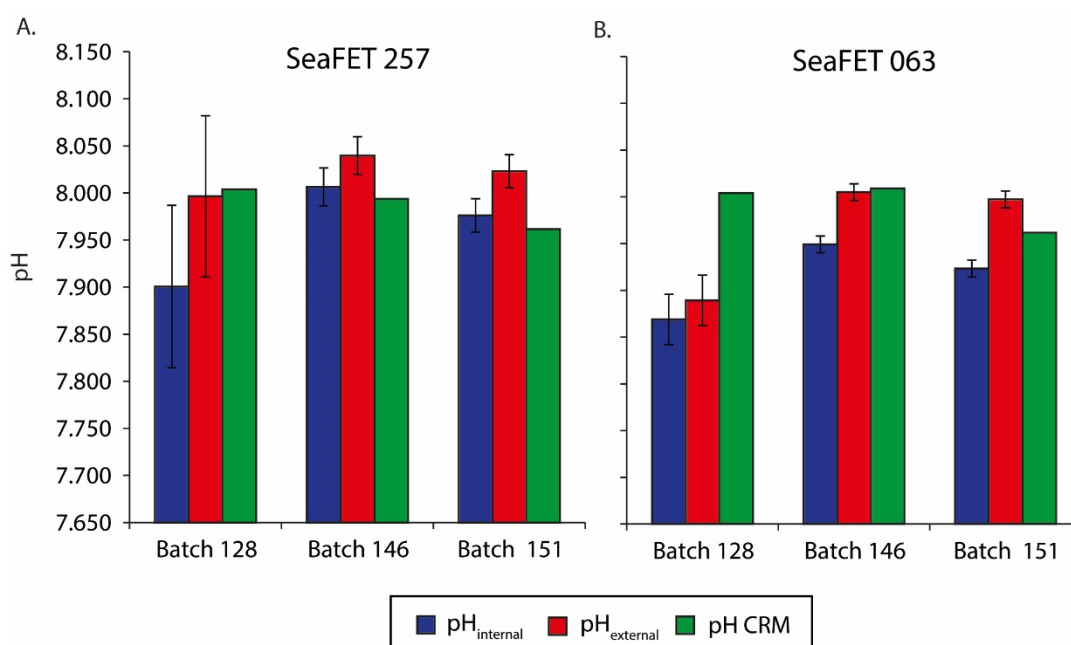


Figure 30: SeaFET 257 (A) and 063 (B) pre-deployment calibration

11.8.2 Deployment on the buoy and sensor frame

SeaFET S/N 063 was deployed on the buoy and SeaFET S/N 257 was deployed on the sensor frame at 30 m. During deployment, both sensors are powered by an OceanSonics battery pack. They can also be powered from the hub or from an internal small battery pack. On the frame, SeaFET was set up to sample in periodic mode with a sampling interval of 30 min and 1380 sec offset (23 min past the hour), producing 3 Frames per burst (output of 3 samples, each is an average of 10 readings) and creating a DAILY log ASCII file (Fig. 30). On the buoy, SeaFET was set up to sample in PERIODIC mode with a sampling interval of 30 min and 1620 sec offset (27 min past the hour), producing 3

Frames per burst (output of 3 samples, each is an average of 10 readings) and creating a DAILY log ASCII file. Note that the sampling regimes cannot be changed remotely.

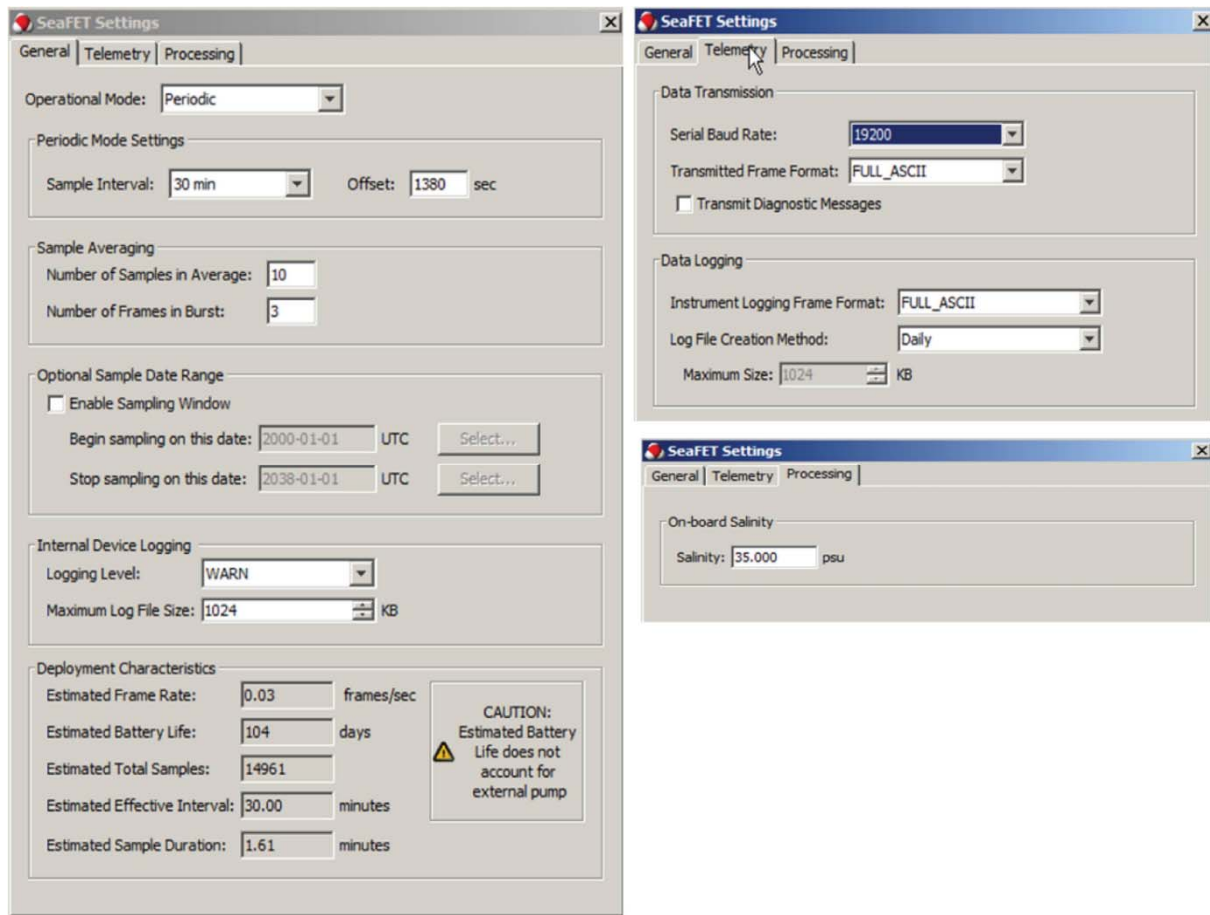


Figure 31: SeaFET 257 pH sensor configuration for the deployments on the frame

11.9 SeaFET recovery and calibration

The SeaFET sensors S/N 105 (frame) and 111 (buoy) deployed during DY050 in April 2016 were successfully recovered on 17.04.2017 (Fig. 31). The sensor slot of both instruments was covered with a relatively thin layer of biofilm (Fig. 31B).

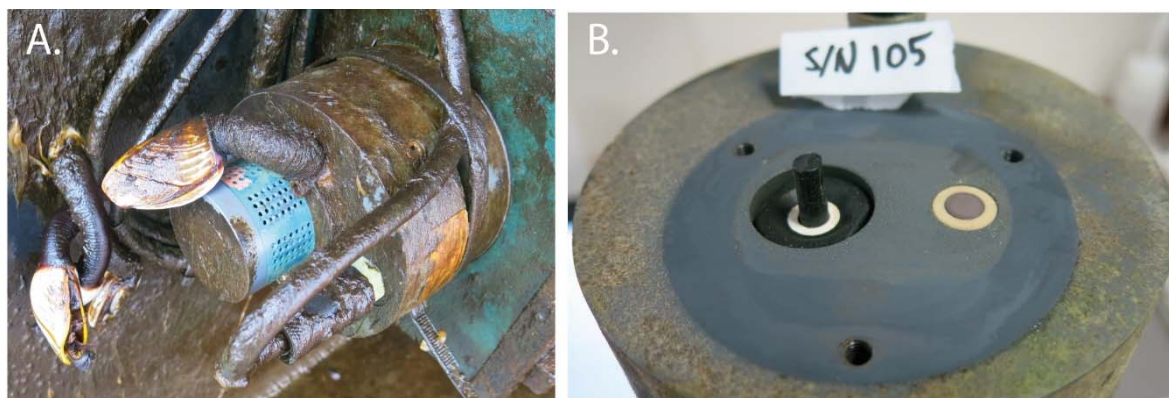


Figure 32: Recovered SeaFET pH sensors after one year of deployment: A. S/N 111 deployed on a buoy; B. Biofouling on sensor slots of SeaFET S/N 105 deployed on a sensor frame at 30m depth.

The performance of the SeaFETs 111 and 105 post-recovery was tested using CRMs Batch 156 and 141, similar to the pre-deployment calibration procedure described above. The results of the post-recovery calibration test are shown in Figure 32 and summarised in Table 4.

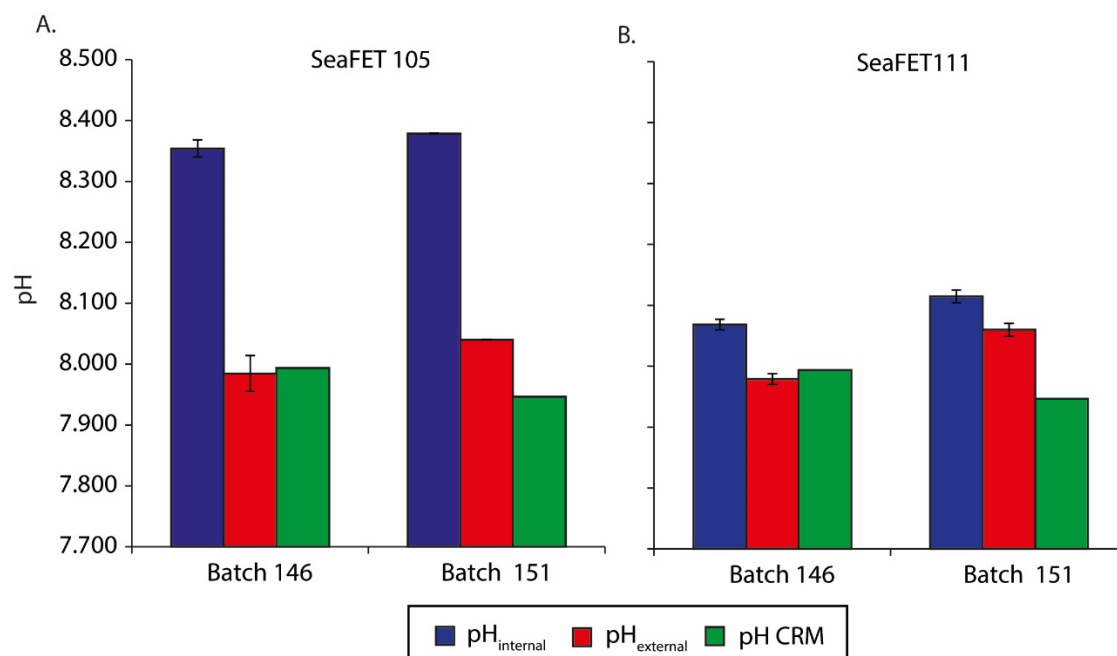


Figure 33: SeaFET 105 (A) and 111 (B) post-recovery calibration

The data collected over a year of deployment was successfully downloaded from the internal memory of both instruments. The SeaFETs 105 and 111 were recording data from 28.04.2016 to 17.04.2017 (Fig. 33).

SeaFET 111 collected data intermittently for the reason yet to be identified. A relatively sharp increase of $\text{pH}_{\text{internal}}$ recorded by SeaFET 105 (Fig. 33C) might be caused by drying out of the gel which acts as an internal calibrant. The temperature records agreed relatively well between the two sensors.

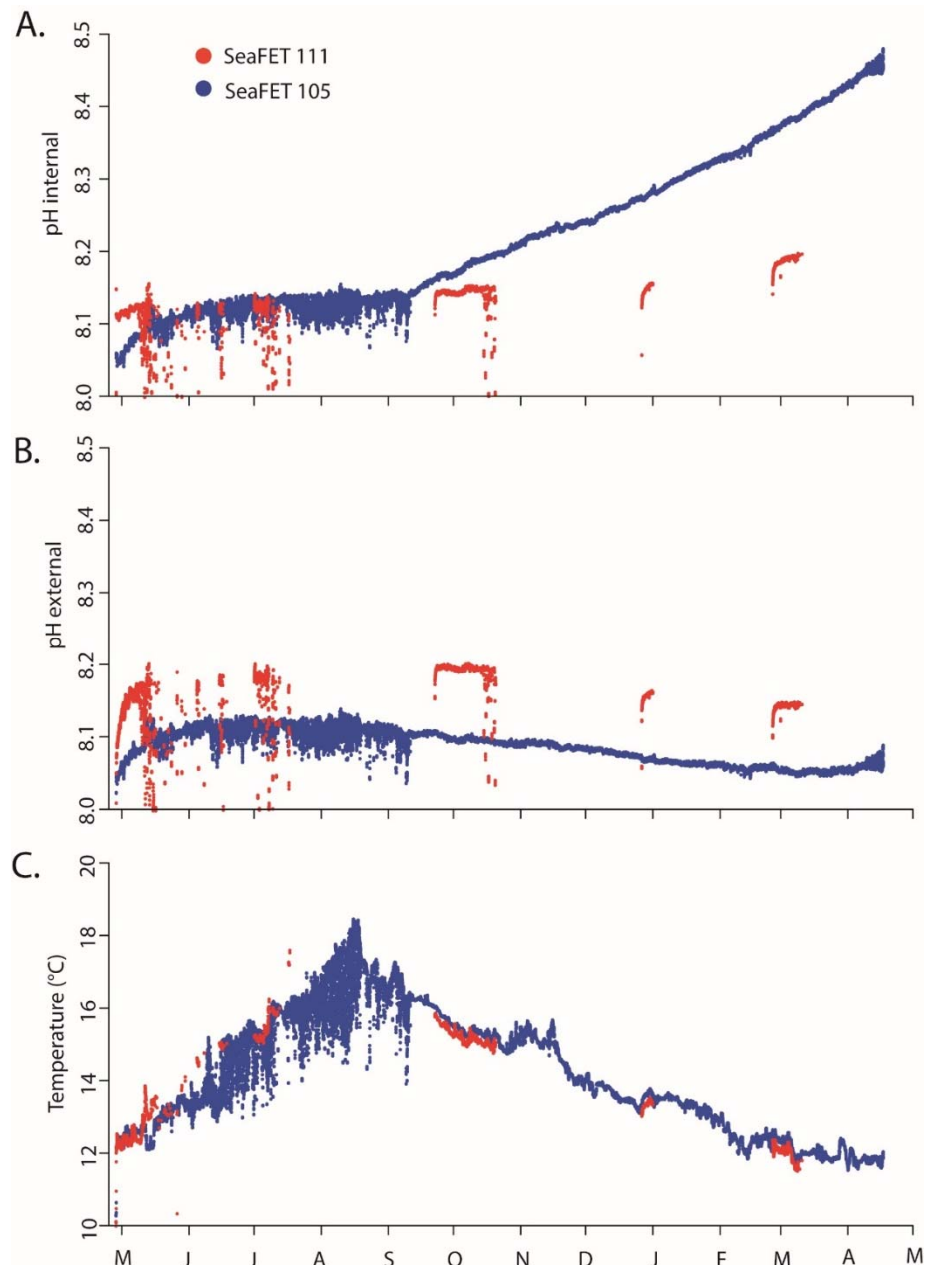


Figure 34: Data collected by SeaFET pH sensors S/N 111 (red; buoy) and S/N 105 (blue; sensor frame) from 28.04.2016 to 17.04.2017. No calibration has been applied.

Table 4: Pre-deployment (S/N 257 and 063) and post-recovery (S/N 105 and 111) calibration tests for SeaFET pH sensors

SeaFET S/N	CRM	pH _{internal}	pH _{external}	Temperature (cell, °C)	Temperature (°C)	pH CRM
<i>Lab calibration 01.02.2017</i>						
257	Batch 128	7.901±0.086	7.997±0.086	20.001±0.015	20	8.004
63	Batch 128	7.869±0.027	7.889±0.027	20.93±0.005	20	8.004
<i>On board calibration 15.04.2017</i>						
257	Batch 146	8.007±0.02	8.040±0.02	18.781±0.004	19	7.994
	Batch 151	7.976±0.018	8.023±0.018	18.563±0.001	18	7.962
63	Batch 146	7.949±0.009	8.005±0.009	18.963±0.002	18	8.009
	Batch 151	7.923±0.009	7.997±0.009	18.933±0.003	18	7.962
<i>Post-recovery calibration 20.04.2017</i>						
105	Batch 146	8.354±0.014	7.984±0.03	19.117±0.025	19	7.994
	Batch 151	8.379±0.001	8.04±0.001	19.19±0.043	19	7.946
111	Batch 146	8.068±0.009	7.979±0.009	19.307±0.001	19	7.994
	Batch 151	8.115±0.011	8.06±0.011	18.944±0.003	19	7.946

11.10 Star ODDIs Recovery and Deployment at PAP#1

11.10.1 Recovery and calibration

Star ODDIs deployed at PAP#1 below the buoy (5 depths) and on a sensor frame were recovered on 17.04.2017 (Fig. 34). The deployment and recovery data are summarised in Table 5. Star ODDI DST CTD 7729 (25 m) was lost, while Star ODDI DST CTD 7725 did not record any data due to a faulty battery. Figure 35 shows the data collected by Star ODDIs DST CTD 6788, 7724, 7727 and DST-tilt H0454.



Figure 35: Recovered Star ODDI DST CTD sensors (S/N 7724, 7725, 6788 and 7727) deployed below the buoy from 28.04.2014 to 17.04.2017. Sensor 7725 did not collect any data due to a battery fail.

Table 5: Summary of Star ODDIs deployed at PAP#1 below the buoy and on a sensor frame on 18.04.2017

Star ODDI	Type	Deployment depth (m)	Position	Interval type	Interval (min)	Deployment date (dd/mm/yyyy)	Deployment time (dd/mm/yyyy)	Battery (%)	Memory used (%)
8928	DST centi	5	Below buoy	Single	30	18.04.2017	12:00:00	96	0
8929	DST centi	10	Below buoy	Single	30	18.04.2017	12:00:00	96	0
8930	DST centi	15	Below buoy	Single	30	18.04.2017	12:00:00	96	0
8984	DST centi	20	Below buoy	Single	30	18.04.2017	12:00:00	97	1
8985	DST centi	25	Below buoy	Single	30	18.04.2017	12:00:00	97	1
H833	DST centi	30	Sensor Frame	Multiple	Tilt: 1s x 60 measurements; Temperature: 30 min x 48 measurements	18.04.2017	12:00:00	96	1

Figure 36: Uncorrected data collected by Star ODDIs at PAP#1 between 28.04.2016 and 17.04.2017



The performance of the recovered Star ODDIs (S/N 7724, 6788, 7727, H454) was tested on a SAPs cast to 10 m depth (Fig. 36). The sensors were set to sample in a fixed mode every 10 sec. Upon recovery, the Star ODDIs had 50-64% of their charge left and up to 2% of internal memory used. Depth, temperature, salinity and conductivity data collected by Star ODDIs are shown in Figure 37. The data from Star ODDI S/N 6788 appeared to be compromised and thus not included. DST-tilt H0454 sensor collected temperature and depth data only.

Figure 37: Star ODDIs attached to the frame of the SAP unit for a post-recovery calibration test

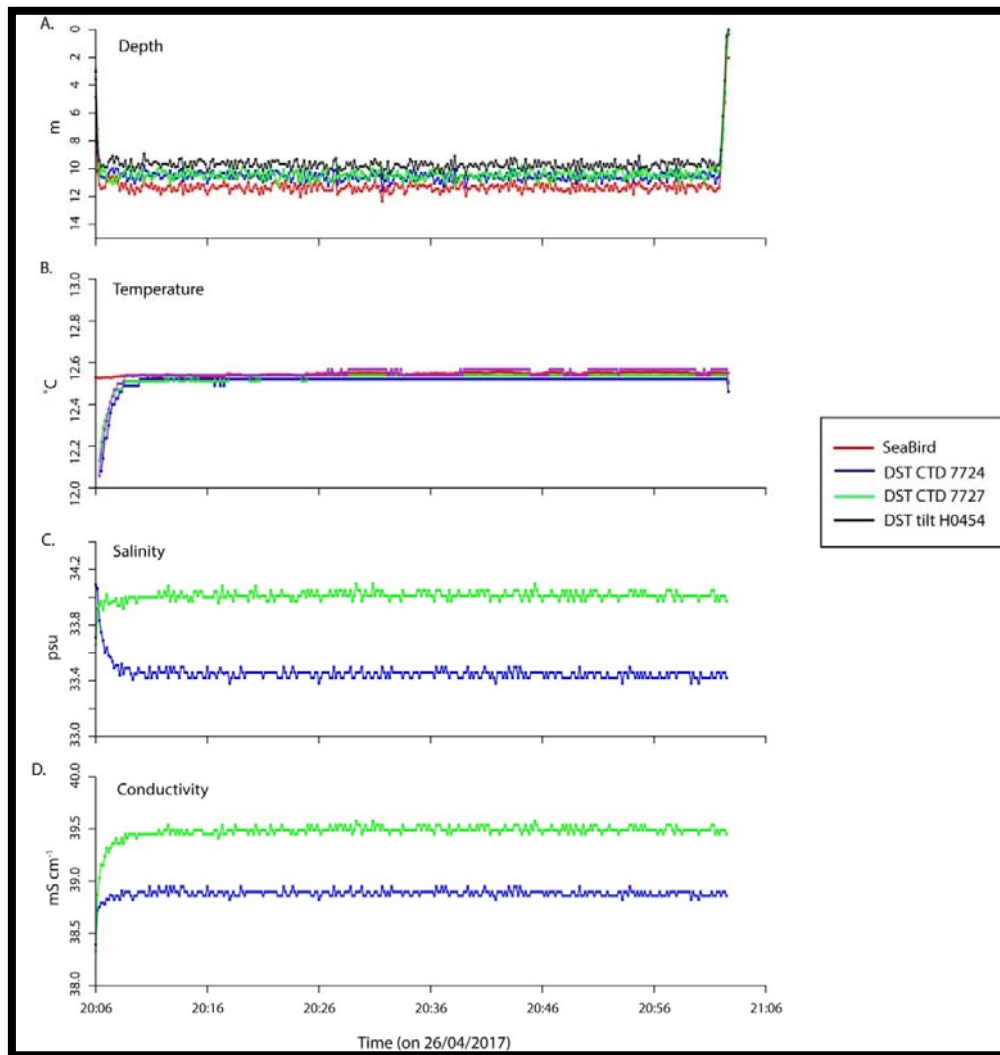
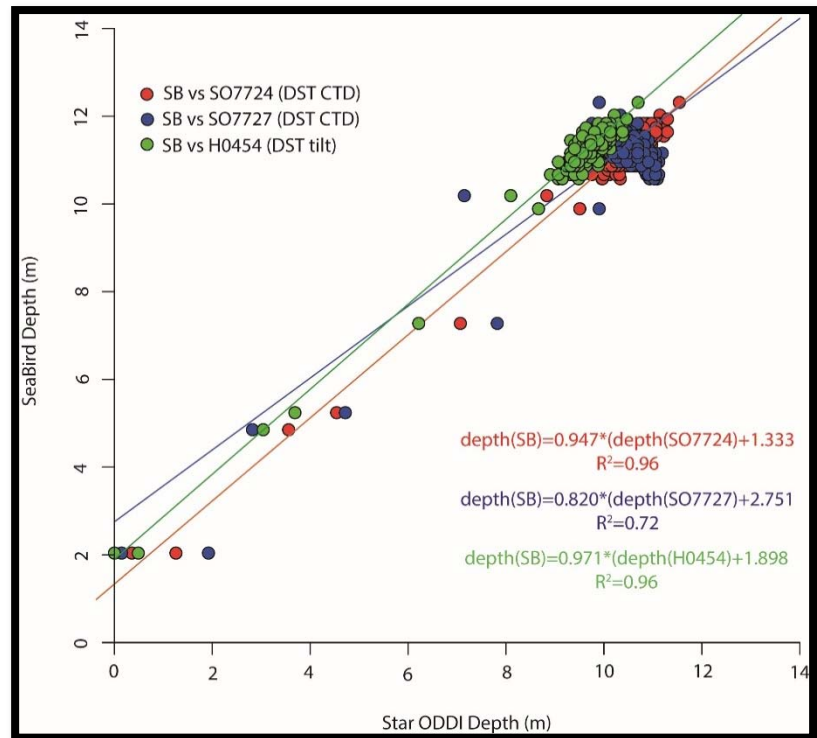


Figure 38: Post-recovery test of Star ODDIs alongside the deployment of an in situ pump equipped with SeaBird Temperature-Depth sensor to 10 m depth.

The relationship between depth data collected by SeaBird and Star ODDIs is shown in Figure 38. A very narrow temperature range recorded at 10 m depth by both sensors (Fig. 37C) precluded a derivation of a strong relationship between temperature data from SeaBird and Star ODDIs.

Figure 39: Calibration of Star ODDIs depth data versus Sea Bird Depth data



11.10.2 Pre-deployment calibration on a CTD frame

Star ODDIs DST centi type (S/N 8928, 8929, 8930, 8984, 8985) and DST tilt (S/N H833) were deployed on a CTD cast CTD001 to 100 m depth and calibrated against the SeaBird 9 + CTD. All sensors were programmed to sample in a single mode with sampling interval of 10 seconds. The calibration of Star ODDI depth and temperature data against CTD values are shown in Figures 39 and 40 and summarised in Table 6. It is likely that Star ODDIs S/N 8928, 8929, 8930 are rated to 50 m depth. We therefore provide an alternative correlation with CTD depth data covering only the upper 50m.

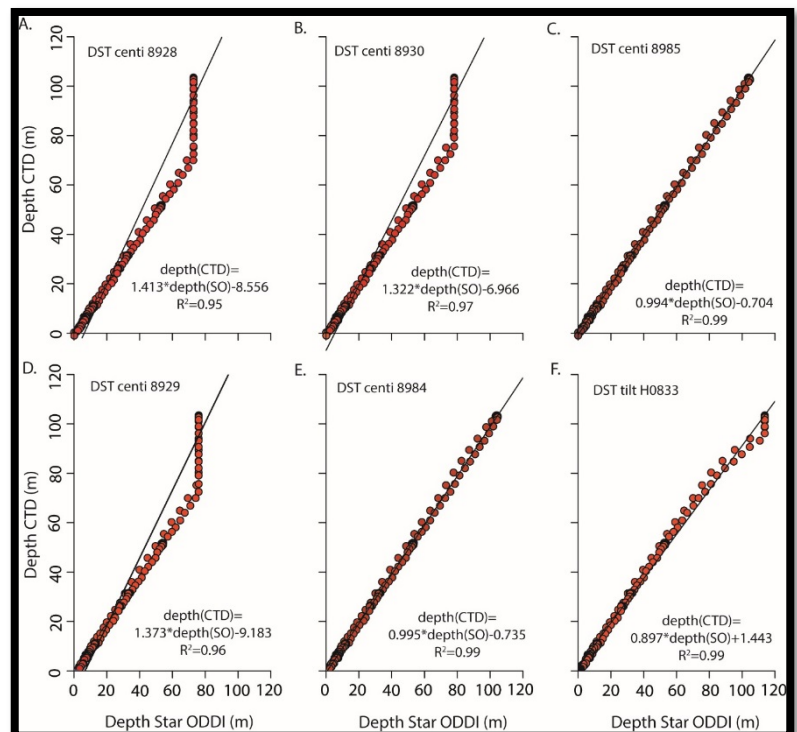


Figure 40: Calibration of Star ODDIs depth data against CTD depth values

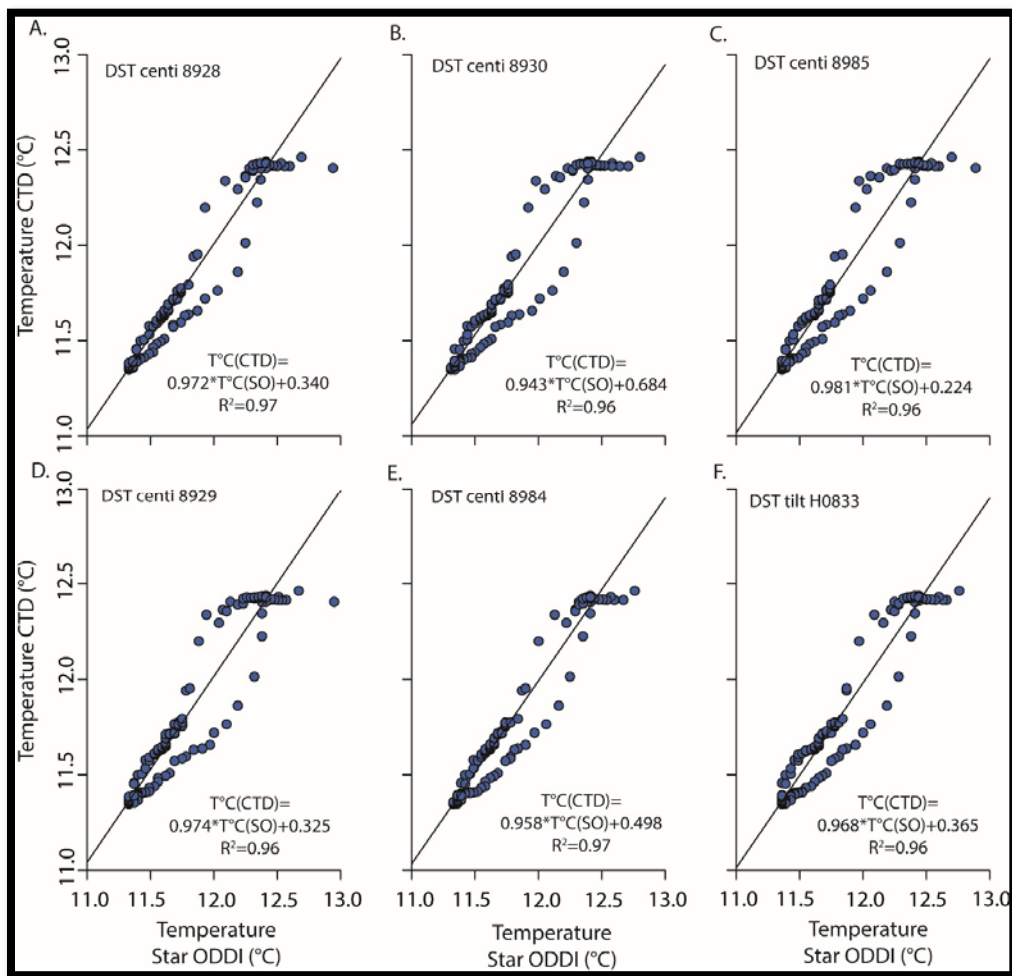


Figure 41: Calibration of Star ODDIs depth data against CTD depth values

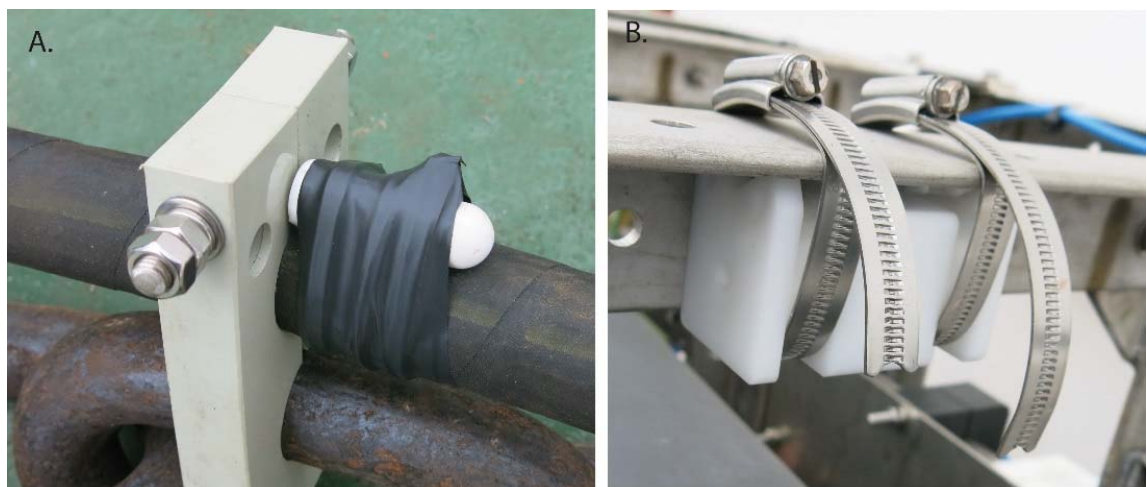


Figure 42: Star ODDI sensors deployed below the buoy (A; all type DST-centi) and on a sensor frame at 30 m depth (B; type DST-tilt).

Table 6: Summary of Star ODDI pre-deployment calibration against CTD

S/N	Depth	R ²	Temperature	R ²
DST centi 8928	depth(CTD)=1.413*depth(SO)- 8.556	0.95	T°C(CTD)=0.972*T°C(SO)+0.3 40	0.9 7
DST centi 8929	depth(CTD)=1.373*depth(SO)- 9.183	0.96	T°C(CTD)=0.974*T°C(SO)+0.3 25	0.9 6
DST centi 8930	depth(CTD)=1.322*depth(SO)- 6.966	0.97	T°C(CTD)=0.943*T°C(SO)+0.6 84	0.9 6
DST centi 8984	depth(CTD)=0.995*depth(SO)- 0.735	0.99	T°C(CTD)=0.958*T°C(SO)+0.4 98	0.9 7
DST centi 8985	depth(CTD)=0.994*depth(SO)- 0.704	0.99	T°C(CTD)=0.981*T°C(SO)+0.2 24	0.9 6
DST tilt H0833	depth(CTD)=0.897*depth(SO)+1.4 43	0.99	T°C(CTD)=0.968*T°C(SO)+0.3 65	0.9 6
<i>0-50 m depth range</i>				
DST centi 8928	depth(CTD)=0.991*depth(SO)- 0.768	0.99	T°C(CTD)=0.942*T°C(SO)+0.6 24	0.9 5
DST centi 8929	depth(CTD)=0.990*depth(SO)- 1.670	0.99	T°C(CTD)=0.961*T°C(SO)+0.9 16	0.9 2
DST centi 8930	depth(CTD)=0.991*depth(SO)- 0.667	0.99	T°C(CTD)=0.909*T°C(SO)+1.1 09	0.9 1

11.10.3 Deployment on a buoy and sensor frame

Star ODDIs were deployed at PAP#1 below the buoy (5 depths; DST centi type) and on a sensor frame (DST-tilt type) on 18.04.2017 (Fig. 41). The deployment summary is given in Table 7.

Table 7: Summary of Star ODDIs deployed at PAP#1 on 28.04.2016 and recovered during DY077

Star ODDI	Type	Depth (m)	Position	Interval type	Interval (min)	Deployment Date (dd/mm/yyyy)	Deployment time (hh:mm:ss)	Recovery date (hh:mm:ss)	Battery before (%)	Battery left (%)	Memory used (%)	Status
6788	DST-CTD	5	Below buoy	Fixed	30	28.04.2016	12:00:00	17.04.2017	62	50	19	OK
7724	DST-CTD	10	Below buoy	Fixed	30	28.04.2016	12:00:00	17.04.2017	67	55	17	OK
7725	DST-CTD	15	Below buoy	Fixed	30	28.04.2016	12:00:00	17.04.2017	NA	NA	NA	No data recorded/ Bad battery
7727	DST-CTD	20	Below buoy	Fixed	30	28.04.2016	12:00:00	17.04.2017	67	55	19	OK
7729	DST-CTD	25	Below Buoy	Fixed	30	28.04.2016	12:00:00	NA	NA	NA	NA	LOST
H454	DST-Tilt	30	Frame	Multiple	Tilt: 1s x 60 measurement Temperature: 30 min x 48 measurements	28.04.2016	12:00:00	17.04.2017	NA	NA	NA	OK

12 Sensor Calibration

12.1 CTD sampling

Sue Hartman, Corinne Pebody, Chelsey Baker

The CTDs were used primarily to test sensors and releases although samples were also taken specifically for the USA Thorium group (to 350m). Samples were also taken to look at typical profiles in the region, for sediment trap water, micro-plastic analysis and method development. The new OTEG phosphate analyser, (initially there was also a nitrate one but it leaked and was removed before CTD 004), were also put onto the frame and triggered to start measurements once sub-merged. As sensors took up room on the frame only 21 of the 24 Niskin bottles were used during DY077.

The first cast was shallow and was used for pre deployment validation of the shallow PAP#1 sensors. Unfortunately there was a problem with the CTD fluorometer and transmissometer (rectified by post processing) and with the oxygen measurements (rectified by a change of sensor on CTD004, but oxygen data could not be retrieved from the first 3 CTD casts).

In retrospect the pre deployment calibration should have been repeated on a later cast, once the CTD sensors were working properly. The wetlabs fluorometer and the Cyclops fluorometer were tested against each other and against the extracted chlorophyll samples. The star oddis, SeaGuard O₂ optode and PAP#1 microcats were also tested on the shallow CTD station 001 for comparison with the CTD and bottle oxygen measurements. There were three 7 minute stops (at 100, 100 and 25 minutes) specifically for the microcat ODO sensors.

CTD003 was the first deep station and was used to test the PAP#3 microcats and releases. Unfortunately there was no CTD oxygen available on this cast. Three 20 minute stops (at 4800, 4000 and 1000m) were used to capture a sample for the OTEG phosphate analyser. The post deployment validation check of shallow PAP#1 sensors was CTD cast 0011, with the testing of the deep microcat on CTD cast 0018. This is summarised in Table 1.

Table 1: A summary of sensors (additional to the CTD sensors and OTEG nutrient analysers) attached to the rosette

CTD Cast	Sensor type	Serial number
001	Shallow Pre deployment sensors: Seaguard Turner fluorometer Seaguard optode Wetlab fluorometer FLNTSUB microcat 37imp ODO Microcat 37imp ODO Microcat 37imp ODO Star oddis	On seaguard 1614 On seaguard 1614 3050 9030 10535 13397 8985, 8984, 8929, 8928, 8930, 833 tilt
003	Deep Pre deployment sensors: PAP#3 microcats & releases Microcat sbe Microcat sbe	 6904 9476
0011	Shallow Post deployment sensors: Wetlab fluorometer FLNTSUB Oxygen microcat odo (from buoy PAP#1) Microcat TS Microcat TS	269 10315 6915 9469
018	Deep Post deployment sensors: PAP#3 microcat 37-imp-66262	9476

In total we had 22 CTD stations (with no bottle samples from CTD002). The station positions are shown in Table 2 for the 7 stations that will be providing data to BODC.

Table 2 CTD station positions, seabed and cast depth

CTD cast (and station)	Latitude (N)	Longitude (W)	Seabed depth (m)	Cast depth (m)
CTD001 (1)	49 03.26	16 20.36	4800	103
CTD003 (7)	49 3.26	16 20.37	4800	4784
CTD004 (31)	48 59.63	16 19.48	4811	350
CTD005 (33)	48 57.17	16 25.92	4810	350
CTD007 (48)	48 58.12	16 28.07	4836	4822
CTD011 (58)	48 50.145	16 31.279	4809	100
CTD018 (85)	48 59.329	16 23.733	4812	4829

On each occasion that samples were taken the order of sampling was: Dissolved oxygen, Dissolved Inorganic Carbon (DIC), inorganic nutrients, salinity and associated parameters from the top 200m. The associated parameters from the surface samples were chlorophyll and PIC. These surface samples were filtered and frozen as appropriate. The PIC samples will be analysed ashore.

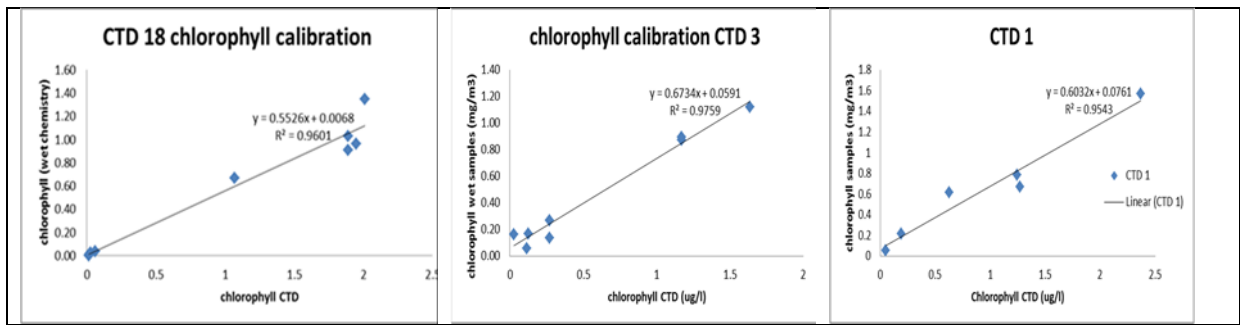
DIC samples were preserved with mercuric chloride and will be analysed on Vindta24 at NOC for Dissolved Inorganic Carbon (DIC) and Total Alkalinity (TA). Duplicates were taken from each station (usually from the deepest Niskin fired). Nutrient samples were collected in centrifuge tubes and frozen for analysis of inorganic nutrients (NO_2+NO_3 , phosphate and silicate) using the Quattro auto-analyser at NOC. Sufficient sample was taken for duplicate analysis.

Generally 3-4 salinity bottle samples were taken from each cast, for analysis on-board at the end of DY077. Chlorophyll samples were filtered and frozen for analysis towards the end of DY077. The oxygen bottle samples were fixed on deck, returned to the deck laboratory and analysis was started within 4 to 7 hours of collection.

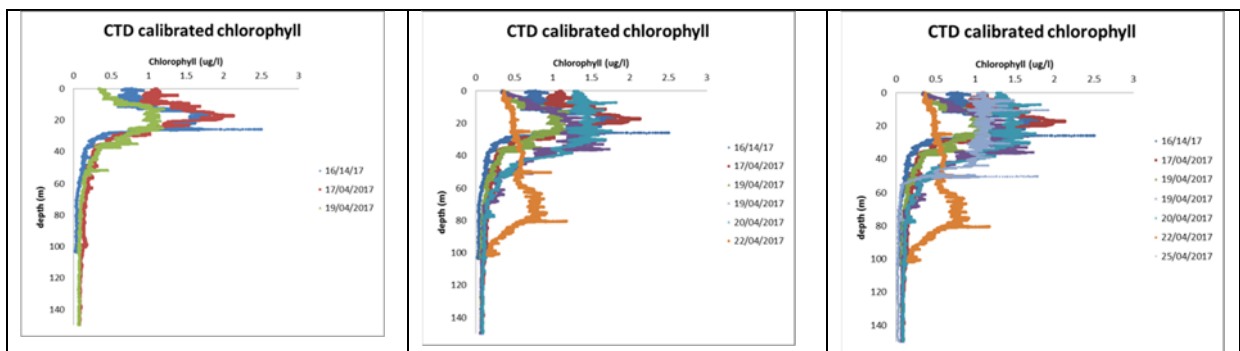
12.2 CTD chlorophyll calibration

Corinne Pebody

The best calibrations came from taking and running chlorophyll samples from CTDs 1, 4 and 18.



CTDs 2, and 11 chlorophyll from CTD and samples regressions showed poor R squares. After review this may have been because large containers were used which were allowed to stand then not shaken sufficiently before filtering. Consequently the calibration from CTD 4 was used because that gave the best R squared.



When we arrived at the PAP-SO the chlorophyll maximum was at 30m. During the next three days it decreased in amplitude and both shallowed and deepened (first of three graphs). Over the next day two CTDs showed the amplitude to be similar to the first few days, showing patchiness around the PAP-SO. There is evidence of surface mixing on 20/04/17 and by the 22/04/17 the CTD showed the chlorophyll max deepened to between 60 and 80 metres (second of three graphs). By 25/04/17 the chlorophyll was well mixed from zero to 50 metres (third of three graphs). The top 100 metres are showing increasing production, stratification, and mixing as the spring bloom is beginning at the PAP-SO.

POC was collected from 4 CTDs. The samples to be analysed will be reviewed on return to NOC.

	date	19/04/2017	20/04/2017	22/04/2017	25/04/2017
	stn no	31	48	58	85
	CTD	4	7	11	18
Depth(m)	5		X	X	X
	10	X	X	X	X
	25	X	X	X	
	30		X	X	X
	35	X			
	50	X	X	X	X
	70	X			
	75		X		X
	80	X		X	
	90	X			
	100	X	X	X	X
	150	X			
	200	X	X		X
	250	X			
	350	X			
	500		X		
	800		X		
	1000		X		
	2000		X		
	3000		X		
4000		X			
4600		X			
4750		X			

12.3 Oxygen analysis on-board

Sue Hartman

In total 85 samples were analysed for dissolved oxygen using a modified Winkler technique. An amperometric end point method was used, following the titration using an electrode to a set end point. Thiosulphate titrant was delivered using a Titrino 794.



Old 'FerryBox' dissolved O₂ amperometric end point equipment set up for O₂ analysis on DY077

The method was standardised using 5ml additions of 0.01N OSIL iodate (3 bottles were used during DY077). The normality of the thiosulphate was initially 0.14 but changed to 0.102 following replacement of thiosulphate after CTD cast 5. Duplicate samples were taken on each cast (usually from the deepest depth). The average duplicate difference was 0.8 $\mu\text{mol/l}$ (0.3%), which is higher than would be expected (0.1%). The use of newer bottles and equipment should be considered in future. The temperature was taken on deck to account for any changes in bottle volume.

So that the oxygen bottle data can be compared with the CTD sensors it is necessary to convert the dissolved oxygen units from $\mu\text{mol/l}$ to $\mu\text{mol/kg}$. This can be done by dividing the values with the *in situ* density.

The CTD files were reprocessed to provide oxygen in ml/l and for calculations of density (with thanks to James). However the density values obtained differed from those used on DY050, so some re-processing will be required.

A constant density of 1.025 is recommended by some groups (eg: ICES and Pangaea) for unit conversion. Additionally ρ was calculated (with thanks to Katsia) using a script in 'R' for CTD cast 007 and the values were close to those seen on DY050. In the reprocessing of CTD density11 was also calculated (with thanks to James) and gave similar results. The effects of these density corrections are shown in the figure below.

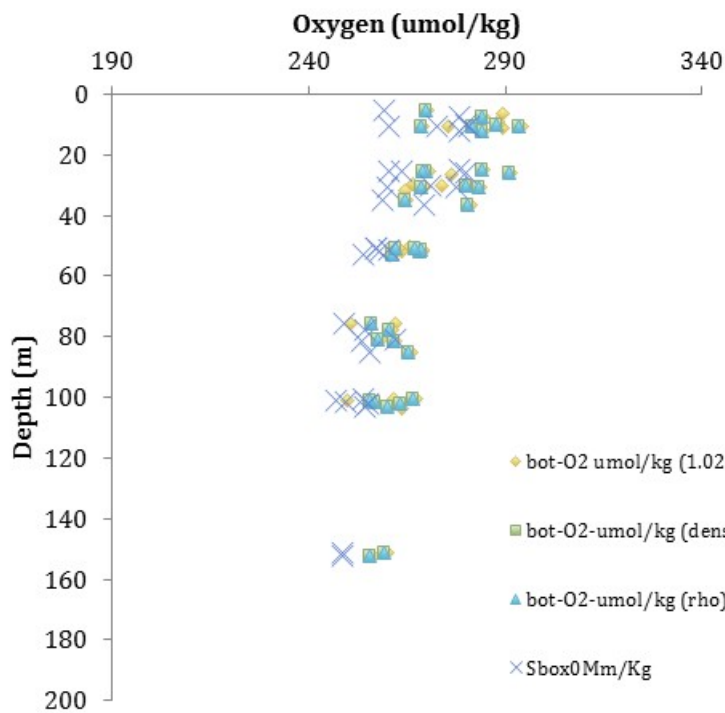
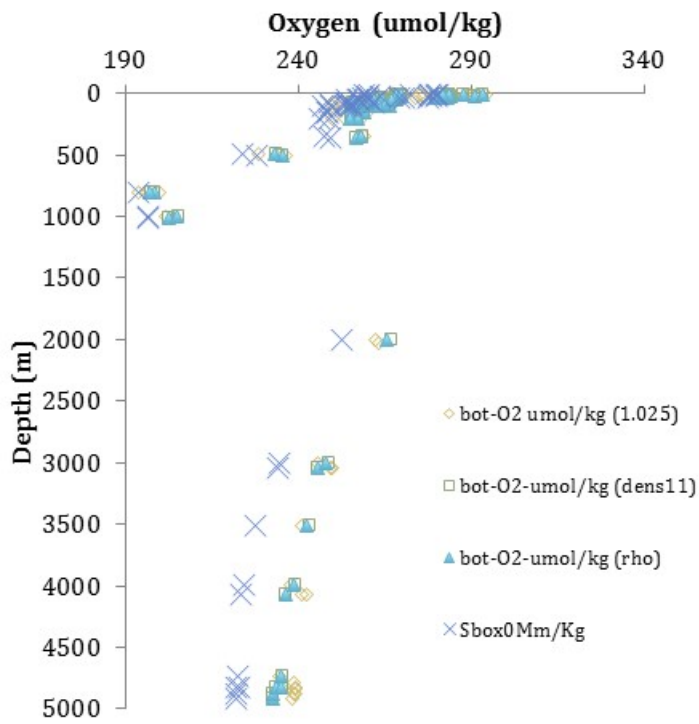


Figure 1 shows oxygen data from the CTD seabird sensor compared with bottle oxygen data (converted from $\mu\text{mol/l}$ to $\mu\text{mol/kg}$ using in situ density rho, density11 and by using the average 1.025 density); showing A) full depth B) top 200m

As seen in Figure 1 the use of rho (or in situ density) improved the unit conversion over the use of an average density but the effect is only seen at full depth. Bottle oxygen data is offset by 10umol/kg at full depth (and 8umol/kg at 200m) so will need some further processing (for density), which may improve agreement between the CTD and bottle data.

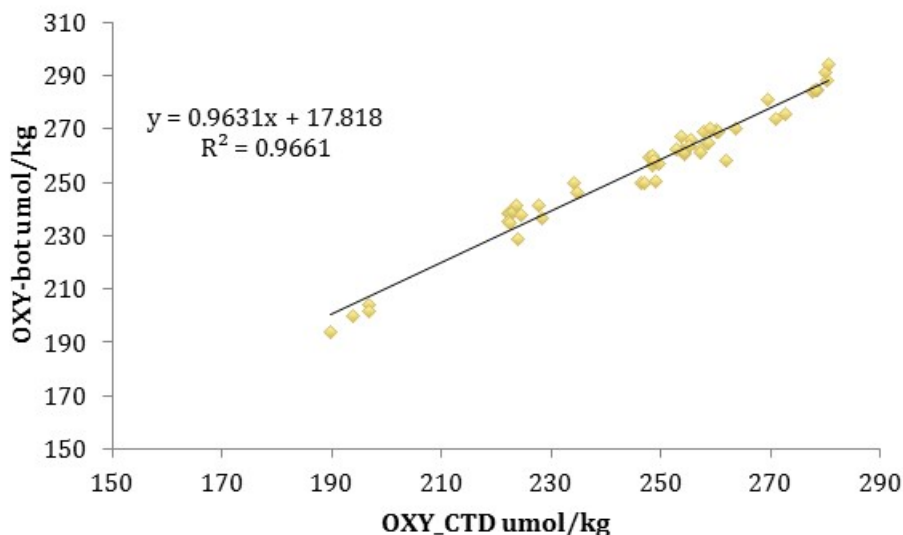
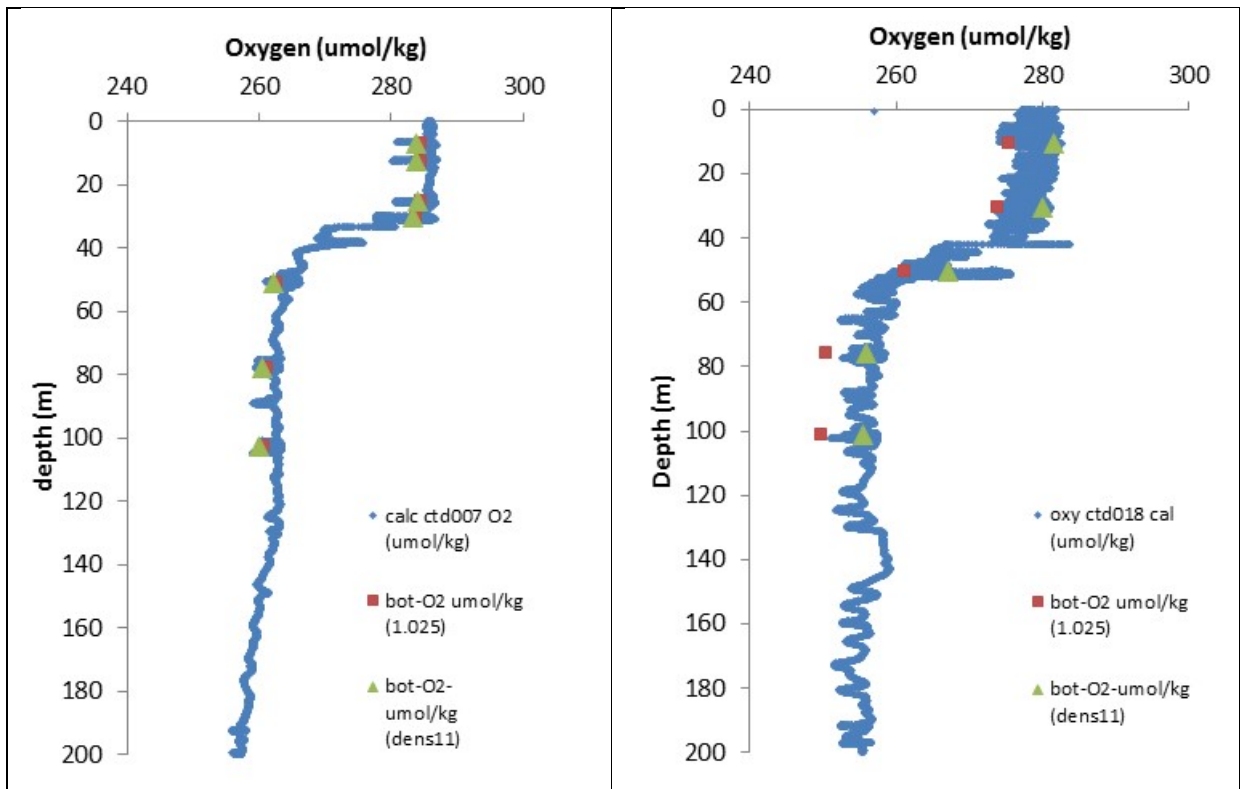
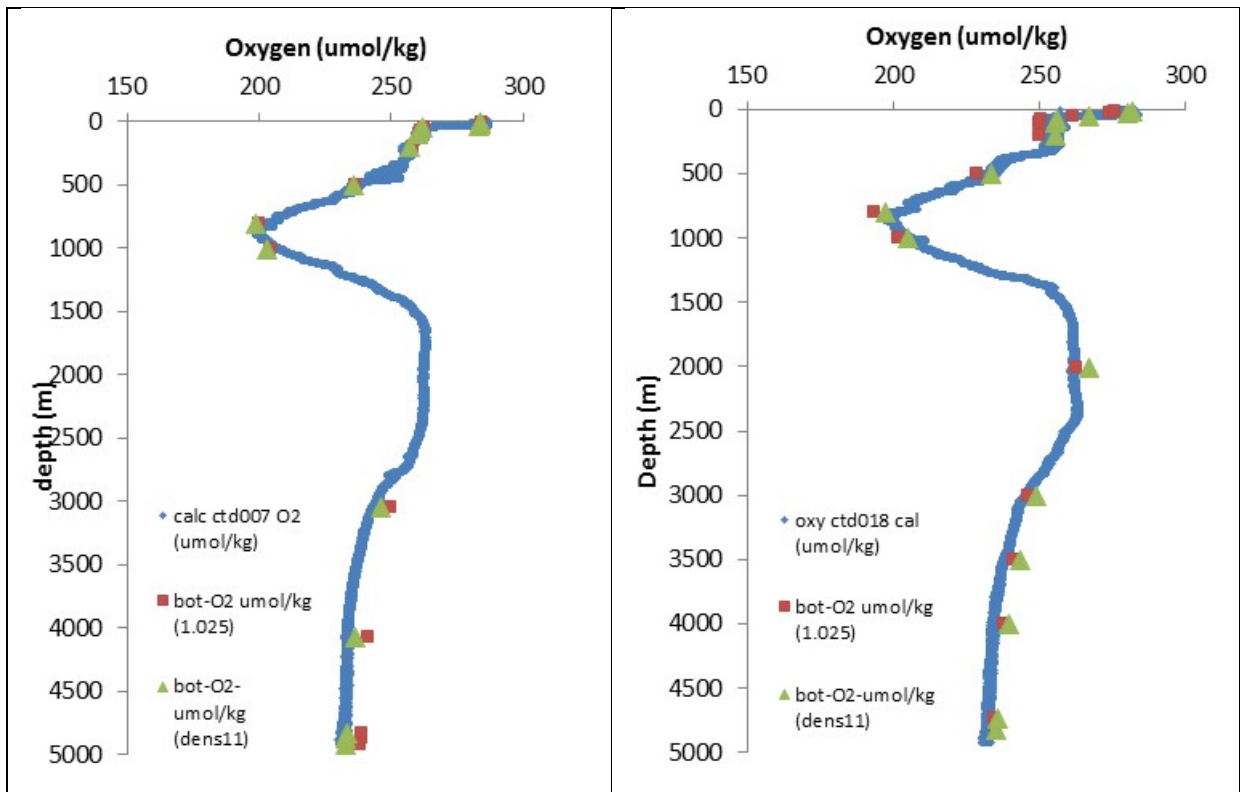


Figure 2 shows the overall relationship between the bottle oxygen (converted using average density 1.025) and CTD oxygen data

This equation can be applied to the CTD oxygen data (see examples in figure below, for CTD07 and CTD 18). The final merged bottle oxygen data are available in a file called: 'All-Final-Oxygen-DY077'.

The full depth profiles show a clear oxygen minima around 900-1000m (Med water influence) and oxygen increases again around 1500m before decreasing in the Lower deep water. The shallow profiles show the change in MLD between casts and increases in dissolved oxygen corresponding to the changing depth of the DCM.



Comparison of two calibrated oxygen profiles (from CTD07 and CTD18) showing 0-5000m and 0-200m

13 Underway Sampling and CO₂ Measurements

Sue Hartman

Bottle samples were taken from the non-toxic (NT) supply seawater at the sampling point next to the thermosalinograph (TSG) on the main deck, one deck down from the CTD sampling. Samples were taken 2-3 times a day for DIC, salinity and nutrients. Salinity analysis was done on-board, at the end of DY077.

The DIC samples preserved for analysis on Vindta 24 at NOC. These samples will be analysed for DIC and TA and calculations made of pCO₂ for comparison with the NOC and the PML underway pCO₂ systems. At the start of DY077 the PML Dartcom (showerhead CO₂) system was installed (with 3 associated calibrant gases). We paid for the system to be set up and this was done by Iain Brown (from PML). The full dataset will be assessed and made available via PML after DY077. Ad hoc readings were taken from the output screen whenever the TSG was sampled for DIC and TA (may thanks to Lisa for assistance with this).

The NOC underway CO₂ recording system (designed by Campbell Ocean data and used previously on the AMT 2016 cruise) was also set up at the start of DY077. This unit was connected to the non-toxic (NT) seawater supply right next to the TSG on the main deck. The NT supply tripped on two occasions during DY077 overnight on the 15th (01:58 to 07:57) and 21st (03:44 to 08:47) April.

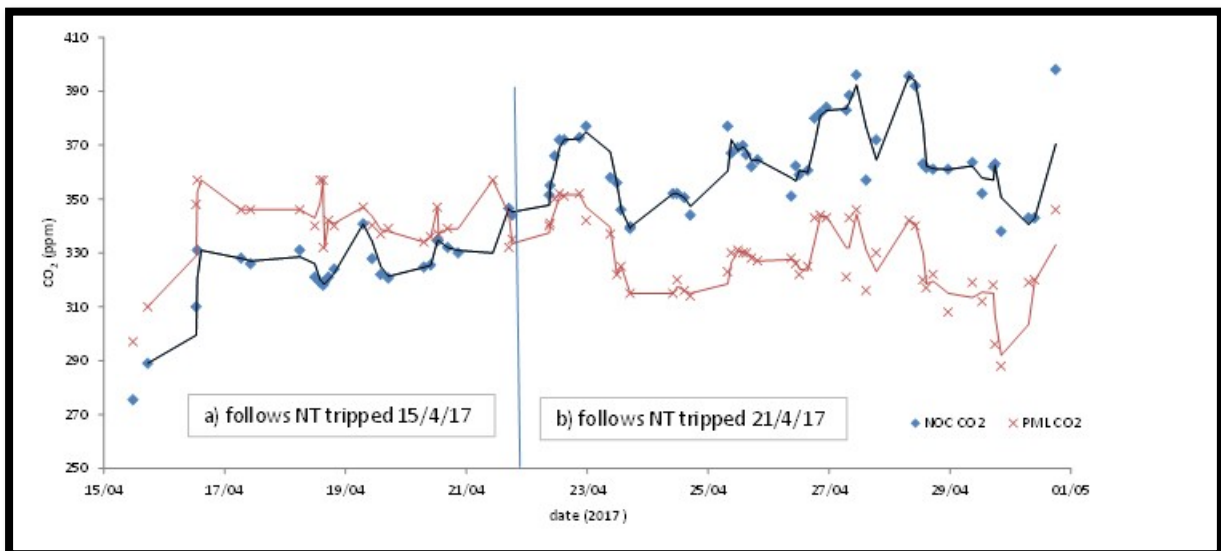


The NOC underway CO₂ system as set up near the TSG system on the main deck

The system comprised of an 18-litre plastic water tank containing an open head Pro-Oceanus CO₂ ProCV sensor (SN 33-156-75 with internal 56 degC temperature) and a Pro-Oceanus GTD-Pro gas tension sensor (SN 33-162-14). The ProCV sensor was set to an 8 hour cycle of zero measurements

(where the CO₂ is stripped using the internal ascarite tube). This cycle was set for midnight, 8am and 4pm. The zero is used to correct for any sensor drift and as measurements take a few minutes to recover following the zero sampling was avoided at this time.

In addition, the tank housed two Aanderra 4330 oxygen optodes (SN 1284 and 1296) and an Aanderra 4319 conductivity sensor (SN 855). A seabird pump was used to stir the water in the tank and a flow meter was used to monitor the flow (generally 5-7 litre/min). These were all connected to an interface box providing 12V power. The RS-232 serial communication signals were passed to a laptop and recorded into daily files. Values were noted manually and recorded to a log sheet 2-4 times a day, generally coinciding with sampling. A coincident record from the PML underway CO₂ system and from the TSG was also taken. A comparison of the NOC and PML CO₂ underway output is shown in the Figure below.

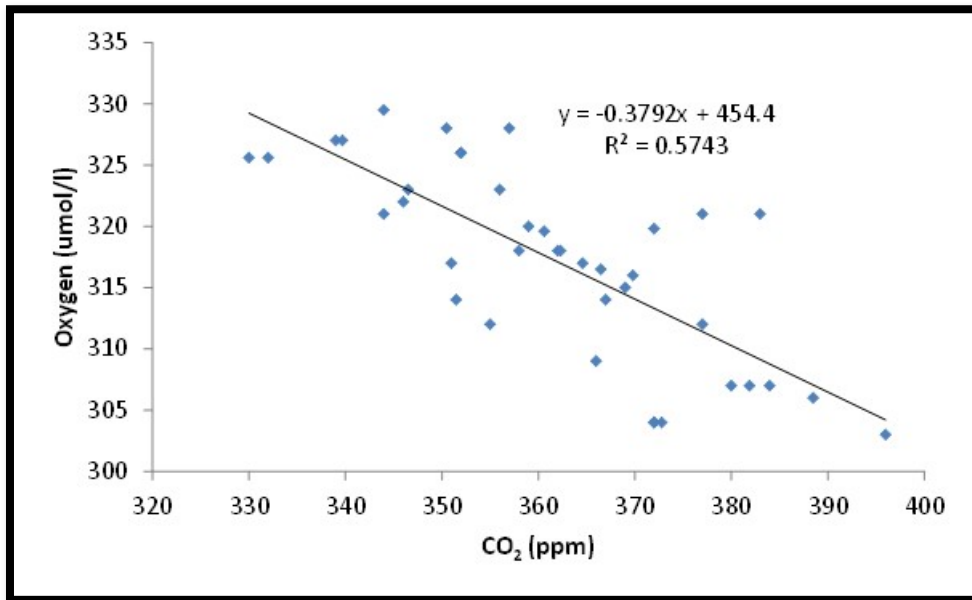


Comparison of CO₂ (ppm) from the NOC and PML underway CO₂ equipment a) before the NT supply stopped and b) after the NT was restarted

The Figure above shows that the two underway CO₂ systems tracked each other fairly well initially, with higher values recorded on the PML system before the NT supply shut down overnight on the 21/4/17. There was an offset of approximately -18 (+/-10)ppm for the NOC system. After the NT system restarted the NOC values were higher than from the PML system, there is a drift in the membrane CO₂ system. The tank and sensors were cleaned, followed by a restart of the NOC system. However the offset increased; on average the NOC values were higher by 35 (+/-14) ppm.

The underway CO₂ systems were run until 18:15 GMT on 30th April, just prior to the NT being switched off at 21:00. The CO₂ results will need to be corrected for using atmospheric pressure and temperature. The temperature at seawater inlet, in the TSG, NOC and PML systems will all

potentially differ as they use different temperature sensors and because they are not located in the same place. There will also be a comparison with CO₂ calculations (using CO₂SYs) once the DIC/TA samples have been analysed. The underway oxygen data showed an inverse relationship to the CO₂ in the NOC system (see Figure below).



Comparison of NOC CO₂ and O₂ underway sensor data

14 Sediment Trap Mooring PAP#3 - Science

Corinne Pebody

The 2017/18 PAP#3 sediment trap moorings were deployed on 20th April 2017 and the 2016/7 traps recovered on 24th April 2017. Traps A, B, C and D were recovered successfully. However it was apparent that trap D did not rotate at all.

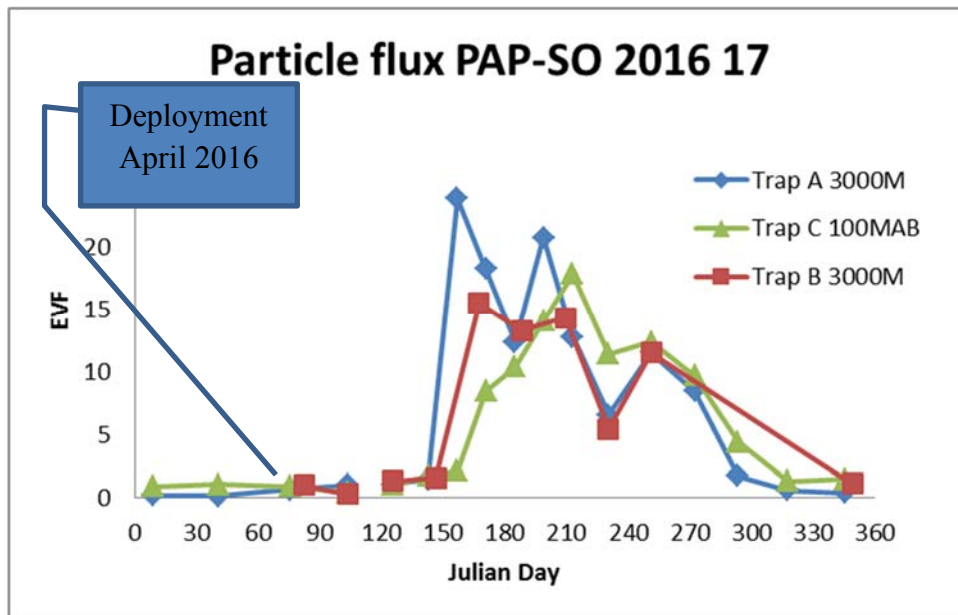
On recovery, the bottles were removed and lids screwed on before removing to the general purpose lab.

The bottles were photographed (see Figures below) and the pH checked. Then 1ml of formalin was added before the bottles, an extra layer of parafilm was added then the lids replaced and samples stored in the chill room.

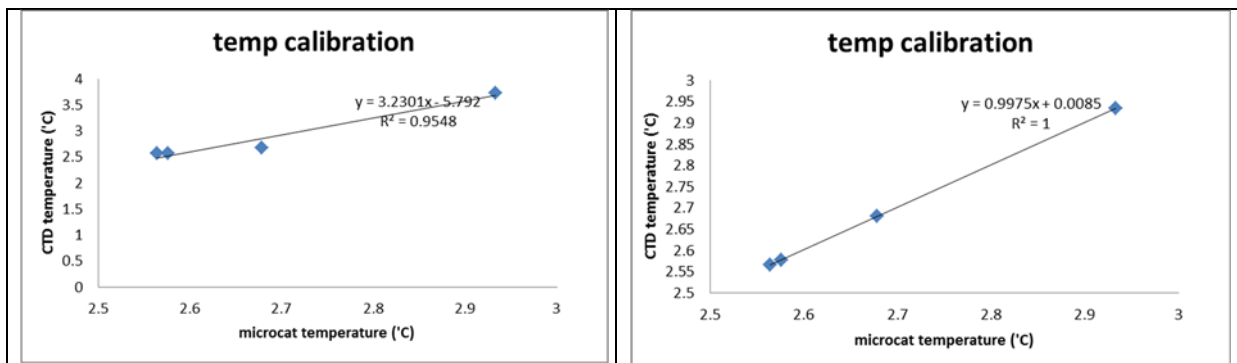


Figure 43 Bottles from 3000m 2016 – 2017 with bottle 3 being measured and showing the spring bloom has started about to start in bottle 16.

The bottles were measured for estimated volume flux; a quick bit reasonable measure of the particle flux over the deployment year. The graph below illustrates the summer bloom of 2016, the drop off over winter and that the 2017 bloom yet to begin.

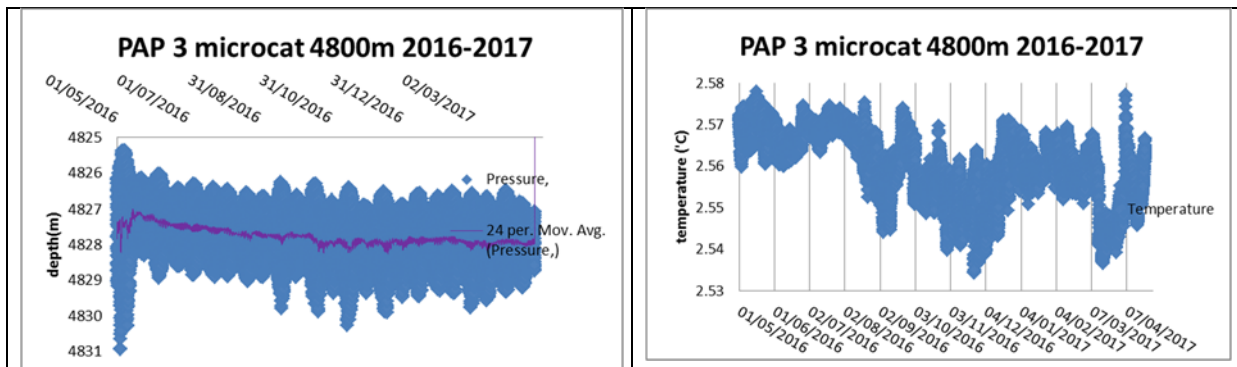


The microcat was calibrated and downloaded and the Norteks were downloaded too.

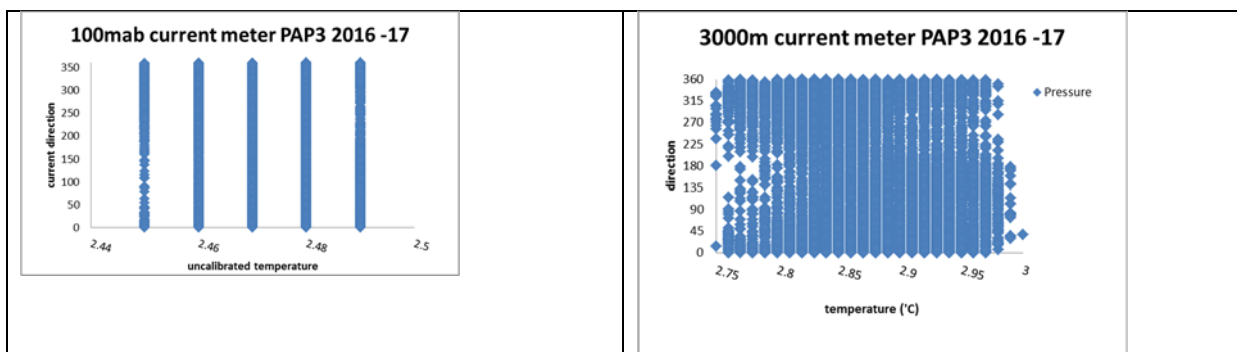
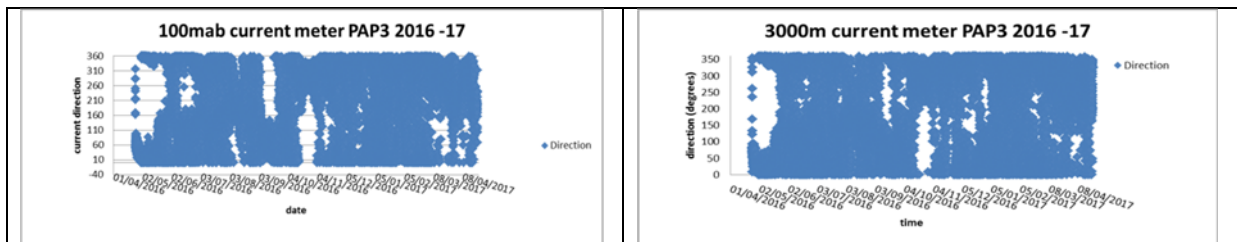


The microcat was deployed on CTD to 5000m and the temperature calibrated against the CTD.

The initial calibration was quite good with an R squared of 0.95, but by using only the deep part of the CTD, in the water temperature where the microcat was actually deployed, the R squared equals 1.



Using the data from the deployment we can see a fluctuation in the pressure, even at 4900m and a change in temperatures too with low temperatures in September, November and March. This is really exciting as we have observed change before but have now been able to calibrate the instrument properly, so can have confidence in the numbers. The current meters show that the current speeds are generally less than the 0.15m/second speeds at which the traps are expected to collect well. The direction also changes throughout the year and the pattern is similar, but slightly different on a fine scale, at 3000m and 100mab.



Plotting temperature and direction together does not give any definite pattern, perhaps the coolest warmer does not flow to the east at 100mab or the south at 3000m.

15 Composition and Function of Dissolved Organic Matter

Manuela Hartmann & Claire Evans

Aim and objectives

We aimed to determine the composition and functionality of marine dissolved organic matter (DOM) by the following objectives:

- To collect DOM samples throughout the water column to serve as a resource for later characterisation in the laboratory
- To trial two new organic matter extraction protocols and compare these to the current protocol with a view to improving marine DOM harvests
- To determine whether different source of marine DOM have variable functionality as indicated by their effect on bacterial growth efficiency

Materials and methods

Samples for marine DOM were collected over full profiles of the water column at a depth resolution of 1000m and also at 500, 200, 100, 50 and 5m. After collection the seawater samples were filtered through 47 mm glass fibre filters (Whatman precombusted at 450 °C) and acidified to pH 2 using HCL. Samples were then extracted using either the established protocol of 1g PPL sorbent (Agilent Bond Elut PPL), or by 1 g Oasis HLB (Waters Corporation) or by a combination of 500 mg Oasis MAX (Anion exchange) in sequence with 500 mg Oasis MCX (Cation exchange: both Waters Corporation). In the case of the former after extraction samples were blown to dryness using N₂ gas and washed with acidified HCL before elution with 4 ml methanol and storage at minus 20 °C in precombusted glass vials. Samples extracted onto Oasis cartridges were stored frozen for washing and elution at NOC. For each extraction a DOC sample was taken and also a particulate sample collected and stored frozen for potential later analysis. Extraction efficiencies will be calculated using DOC concentrations in the extracts and chemical characterisation will be via a variety of targeted and untargeted mass spectrometry platforms.

DOM for functionality characterisation was generated in laboratory cultures from the host organisms *Synechococcus* and *Emiliana huxleyi*. DOM was generated by either microzooplankton grazing with the predator *Oxyhrius marina*, light starvation or exudation. Matter was extracted (using PPL), blown to dryness using N₂ gas and stored frozen. DOM samples were reconstituted using 0.2 µm filtered seawater at an appropriate volume to generate a final concentration of 12.03 mM. This was combined with whole seawater to generate appropriate final DOM concentrations according to experimental requirements.

We aimed to develop a suitable protocol to determine bacterial growth efficiency (BGE) in DOM amended treatments. To determine bacterial production we used the standard method of Simon and Azam (1989) and also trialled an isotopic dilution time series bioassay (Wright and Hobbie, 1966, Zubkov et al. 2004) to provide a more refined measurement of leucine uptake rates. For the former L-[4,5-³H]-leucine (specific activity 101 Ci mmol⁻¹) was preloaded into 2 mL polypropylene crystal clear microcentrifuge tubes (Starlab, Milton Keynes) to make a final concentration of 10 nM when combined with the 1.6 mL seawater samples. Paraformaldehyde was added to one replicate at a final concentration of 1% to serve as a 'killed' control. All treatments were then incubated in the dark at *in situ* temperature for 4 h. Samples were then fixed by the addition of formaldehyde and filtered onto 0.22 µm pore size, cellulose nitrate filters (Millipore HA). The filters were washed twice by the addition of 5% chilled trichloroacetic acid for 5 min and then transferred into scintillation vials and stored at minus 80°C until analysis. Prior to analysis 1 ml of ethyl acetate was added to the vials to dissolve the filters. After 10 min, 8 ml of scintillation cocktail was added and the samples were analyzed after 6 h on a Tri-Carb 2910TR liquid scintillation counter.

For the isotopic dilution time series bioassay L-[4,5-³H]-leucine (specific activity 101 Ci mmol⁻¹) was preloaded into 2 mL polypropylene crystal clear microcentrifuge tubes (Starlab, Milton Keynes) to make a final concentration series ranging from 0.2 to 1 nM when combined with the 1.6 mL seawater samples. Immediately after collection, seawater was combined with the labelled substrate (marking the start of the experiment) and a sample from each concentration was fixed at 10, 20, 30 and 40 min by addition of 1% final concentration paraformaldehyde. Particulate matter in the samples was harvested by filtration onto 0.2 µm pore-size polycarbonate filters, which were then washed twice with 3 mL of deionised water. To determine the radioactivity of the retained particulate matter the filters were analysed by liquid scintillation counting (Tri-Carb, 3100TR, Perkin-Elmer, Beaconsfield, UK). Leucine uptake rate was calculated as previously described by Zubkov and colleagues (2007).

Respiration was measured by determining changes in oxygen concentrations over time in either sealed 4 ml glass microrespiration chambers (Unisense) and a Clark type oxygen sensor (Unisense) or in 4 ml Chromacol vials equipped with sensor spots and an Optode (Presense). Prior to use the sensor and the optode were calibrated by a two point calibration of O₂ saturated Milli Q water, generated by continuous bubbling with air, and an oxygen free solution, produced by mixing 1 g of sodium sulphite with a litre of Milli Q water. Chambers and vials were incubated in the dark at *in situ* temperature and all sample handling was done under red light. Measurements were performed with the Unisense sensor by placing it into the chamber and allowing 10 minutes for the signal to stabilize. For the Presense system the optode was held against the sensor spot and a measurement was taken after the signal had stabilized.

We conducted experiments to determine the effective DOM concentration required to produce a measurable change in leucine uptake rates using the concentrations of 6, 30 and 60 μM , which represent an enhancement of background DOM of 10, 50 and 100%. Using the appropriate concentration three experiments were conducted to compare our different DOM samples, two from the chlorophyll max and one from 1000m representative of the pelagic and mesopelagic zones respectively. The latter community would have been conditioned to a lower supply of labile organic matter, thus facilitating a more pronounced response to our DOM amendments.

Results and Discussion

Experiments revealed that the bacterial production method of Simon and Azam (1989) lacked the sensitivity to measure differences in those treatments amended with our DOM samples. Therefore, we elected to measure leucine uptake using the isotopic dilution time series bioassay. A final DOM concentration, superimposed over the ambient DOM concentrations, of 30 μM was found to produce a detectable change in leucine uptake rates allowing differences between the DOM samples to be ascertained, while not saturating uptake capacity. Leucine uptake rates were decreased by the addition of some of the DOM samples indicating they may have increased respiration rates. Measurements of oxygen consumption in the DOM amended samples collected from the chlorophyll maximum were elevated and distinct for the different treatments supporting this assumption, but these differences were not statistically robust. Both oxygen detection methods trialled were found to drift, which may have been due to fluctuating temperature in the 'Constant Temperature' laboratory in which the experiments were performed. In the experiment performed on the mesopelagic community leucine uptake rates were barely detectable making it difficult to determine differences in responses to leucine uptake over the short incubation time.

In conclusion these experiments indicate DOM from different sources does influence bacterial growth efficiency. Best experiment design is to use the isotopic dilution time series bioassay to determine leucine uptake as a proxy for production from communities in more productive zones. In order to measure respiration the experimental design must be refined. Improve temperature control will aid in the elimination of drift in the sensor thus improving accuracy and extending the incubation times will enhance the likelihood of capturing distinct responses to DOM addition.

References

- Simon M, Azam F. 1989. Protein content and protein synthesis rates of planktonic marine bacteria. *Marine Ecology Progress Series* 51:201–213.
- Wright, R.T. and J.E. Hobbie. (1966) Use of Glucose and Acetate by Bacteria and Algae in Aquatic Ecosystems. *Ecology* 47: 447-464.

Zubkov, M. V., G. A. Tarran and B. M. Fuchs. (2004) Depth Related Amino Acid Uptake by Prochlorococcus Cyanobacteria in the Southern Atlantic Tropical Gyre. *FEMS Microbiology Ecology* 50: 153-161.

16 Zooplankton Net Sampling

Corinne Pebody and Chelsey Baker

The WP2, 200 μ m net was deployed to 200m in a series of paired vertical hauls. Prior to each haul, the net was checked for twists and that the tap was closed, then the net was lowered over the side using the Rexroth winch over the starboard side. Maximum depth was 180 metres where the deployment was paused for a minute to allow the net to hang straight before the being brought up at approx. 10 metres per minute.

On recovery the net was hosed down from the outside with seawater and the cod end emptied into a white bucket. Hosing was repeated and time allowed for zooplankton to settle into the bottom of the cod end. Samples were then either, transferred to 2 litre bottles and preserved by adding borax buffered formalin to an approximate concentration of 5%. Alternatively the sample was sieved through a series of meshes, 2mm, 1mm, and 200 μ m and transferred to cryo vials and stored in the -80°C freezer.

Any pteropods were removed for photographing and recording.



Figure 44 Deployed Net

Future work:

At NOC, formalin preserved samples will be split with a Folsom splitter. A sub sample will be picked to remove zooplankton greater than 2mm. Remaining meso zooplankton will be analysed using flow cam technology to ascertain size and abundance distribution.

Figure 45 pteropod and copepods mostly



DY077-017 NET #1	midnight sample	preserved in formalin 2 litre bottles				Water depth
net shot		17/04/17	23:09	48 50.51142 N	16 31.18026 W	4809
at surface		17/04/17	23:38	48 50.27454 N	16 31.14660 W	
DY077-018 NET #2	midnight sample	Sieved into >2mm; ,<2mm; >1mm; frozen at - 80°C <1mm>200µm; <200µm>63 µm				Water depth
net shot		18/04/17	00:05	49 50.27424 N	16 31.145594 W	4809
at surface		18/04/17	00:41	49 50.27418 N	16 31.145618 W	ucm
DY077-039 NET #3	midnight sample	preserved in formalin 2 litre bottles				
net shot		20/04/17	03:12	49 59.01186 N	16 29.71734W	4809
at surface		20/04/17	03:48	49 59.01240 N	16 29.71758W	ucm
DY077-062 NET #4	midnight sample	preserved in formalin 2 litre bottles				Water depth
net shot		23/04/17	22:37	49 50.24100 N	16 31.4730 W	4810
at surface		23/04/17	23:04			Ucm
DY077-063 NET #5	midnight sample	Sieved into >2mm; ,<2mm; >1mm; frozen at - 80°C <1mm>200µm; <200µm>63 µm				
net shot		23/04/17	23:07	48 50.24100 N	16 31.47258 W	4809
at surface		23/04/17	23:31	49 50.24118 N	16 31.47228 W	Ucm
DY077-107 NET #6	noon sample	Sieved into >2mm; ,<2mm; >1mm; frozen at - 80°C <1mm>200µm; <200µm>63 µm				Water depth
net shot		28/04/17	14:19	49 0.84282 N	16 24.62016 W	
at surface		28/04/17	15:02			ucm
DY077-108 NET #7	noon sample	preserved in formalin 2 litre bottles				
net shot		28/04/17	15:07	49 0.86616 N	16 24.65424 W	
at surface		28/04/17	15:36			ucm

17 Microplastics

17.1 Microplastics in the water column

Katsia Pabortsava

I. Microplastics and POC sampling with large volume *in situ* pumps (SAPs).

Microplastics and biogenic particles in the water column were collected with large-volume stand-alone *in situ* pumps (SAPs; Fig. 1A).

The SAPs were deployed at 4 discrete depths collecting particles onto acetone-washed 55 μm stainless steel mesh (pre-filter) and 10% HCl-washed 1 μm NITEX[®] nylon mesh (main filter). Filter loading, sample preparation, and processing were always carried out under the laminar flow hood in a clean lab on board of the ship. The SAPs were set to pump for 60 min filtering between 600-1600 L of seawater when successful (Table 1).

In total, 2 successful SAPs deployments were carried out, yielding 5 samples for 55 μm size fraction (including 2 blanks) and 5 samples for 1 μm size fraction (including 2 blanks) (Table 1). Pumps S/N 03-01 and 03-02 failed at both deployments due to faulty batteries. SAP S/N 02-003 deployed at 10 m depth at station #042 filtered only 300 L likely due to the exhaustion of the charge. The deployment of SAP S/N 02-004 at 10 m depth (station #099) was delayed by 4 min and pumping was initiated whilst still on board. The samples collected with this pump would therefore include particles from surface to 10 m depth.

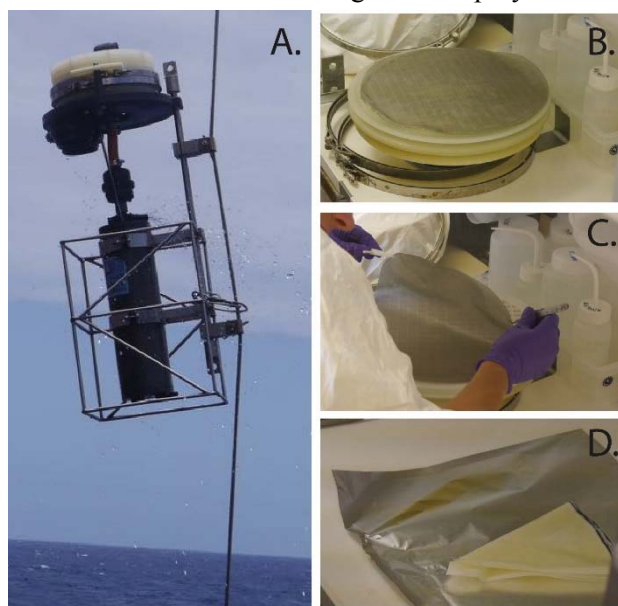


Figure 46: A. Large volume in situ Stand Alone Pump (SAP) used to collect bulk marine particles including microplastics; B-D. Processing particle samples under the laminar flow hood in a clean lab on board of the ship

Upon recovery, the meshes were carefully removed from filter holders, folded and packed into a zip-lock bag (55 μm mesh) and aluminium foil (1 μm mesh) and stored at -20°C until analysis (Fig. 14B-D). For contamination control, 55 μm and 1 μm meshes were prepared as for sampling but not used on a SAP unit. The meshes from the failed pumps could also be used as procedural blanks.

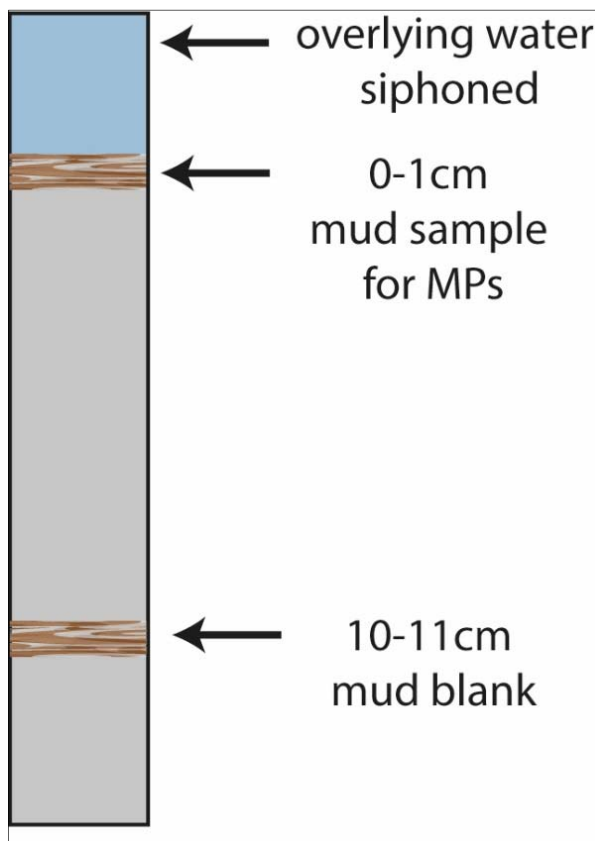
Table 8: Summary of SAPs deployments

Date	Station #	Latitude °N	Longitude °W	SAP S/N	Depth (m)	Volume filtered (L)	Remarks
20.04.2017	042	59.222	28.299	02-003	10	301	
20.04.2017	042	59.222	28.299	03-02	150	2	Failed
20.04.2017	042	59.222	28.299	03-01	500	1690	
26.04.2017	099	49.531	42.288	02-004	10	1049	started pumping on board 4min before deployment
26.04.2017	099	49.531	42.288	02-003	150	872	
26.04.2017	099	49.531	42.288	03-01	500	3	Failed
26.04.2017	099	49.531	42.288	03-02	1000	1605	

17.2 Microplastics in the sediment

Katsia Pabortsava

Sediment core samples were collected by Brian Bett's benthic team to investigate the abundance of microplastics in the deep marine sediments at PAP. Upon recovery, the cores were removed from the megacorer one by one. The core designated for microplastics was immediately covered with foil to prevent any airborne microplastics contamination. The surface water was siphoned through a 250 µm sieve and the sediment remaining on the sieve was collected in a pre-weighed, ashed, acid-clean, glass sampling jar (250 ml). The top 1 cm was sliced off using a metal cutter and added to the sampling jar. Plastics are only likely to be found on the surface sediments since plastic is a modern product. However, bioturbation could make MPs penetrate deeper into the sediment. Hence, for control sample, the next 10 cm of mud sample was discarded and the following 1 cm of mud was collected into a separate jar. The sampling procedure is depicted in Figure 2. The layer of foil was placed between the jar and lid. The wet sample was then weighted wet and dried at 50°C in the oven. The weight of the dry sediment samples and their microplastics content will be determined in the laboratory at NOCS.



Summary of the sediment cores collected for microplastic analysis is given in Table 2.

Table 9: Summary of sediment samples collected with megacorer for microplastic analysis

Jar ID	Date	Time	Station #	Latitude N	Longitude W	Depth (m)	Sample/blank (S/B)	Slice depth (cm)
<i>Figure 47: Diagram of microplastic sampling of a sediment (not to scale).</i>								
DY077 -01	17.04.2017	17:53:00	16	50.246	31.199	4845	S	0-1
DY077 -02	17.04.2017	17:53:00	16	50.246	31.199	4845	B	10-11
DY077 -03	19.04.2017	00:06:00	21	50.038	31.542	4844	S	0-1
DY077 -04	19.04.2017	00:06:00	21	50.038	31.542	4844	B	10-11
DY077 -05	22/04/2017	09:36:00	56	50.309	31.449	4844	S	0-1
DY077 -06	22/04/2017	09:36:00	56	50.309	31.449	4844	B	10-11
DY077 -07	24.04.2017	01:26:00	64	50.251	31.472	4844	S	0-1
DY077 -08	24.04.2017	01:26:00	64	50.251	31.472	4844	B	10-11
DY077 -09	26.04.2017	01:53:00	87	50.340	31.078	4843	S	0-1
DY077 -10	26.04.2017	01:53:00	87	50.340	31.078	4843	S	0-1
DY077 -11	26.04.2017	01:53:00	87	50.340	31.078	4843	B	10-11
DY077 -12	26.04.2017	01:53:00	87	50.340	31.078	4843	B	10-11

17.3 Microplastics and bacteria

Impact of microplastic pollution on the mortality of bacterial communities within the water column

Jessica Song, Katsiaryna Pabortsava, Claire Evans

1. Sampling from the water column

Samples were collected from the CTD from the deep chlorophyll maximum (approx. 35m) with the objective of sampling phytoplankton. A total of 60-80L of water was collected per experiment using 20L HDPE carboys. Water was allowed to flow through a small piece of rubber tubing directly into the base of each carboy to facilitate a soft, even flow to avoid bubbling or agitation that may damage the microorganisms within the sample. Sampling materials were rinsed thoroughly with sample seawater prior to each collection.

Date	Station #	Bottle #	Time	Latitude °N	Longitude W°	Depth (m)
16.04.2017	DY077-001	14-16	20:22	49°03.263'	16°20.378'	25
19.04.2017	DY077-033	14-17	12:18	48°57.143'	16°25.877'	35
20.04.2017	DY077-049	17-19	05:19	49°07.054'	16°37.023'	31
24.04.2017	DY077-078	17-19	17:43	48°59.790'	16°22.083'	20
26.04.2017	DY077-089	15-17	11:55	48°52.072	16°35.172	35

2. Experimental set-up

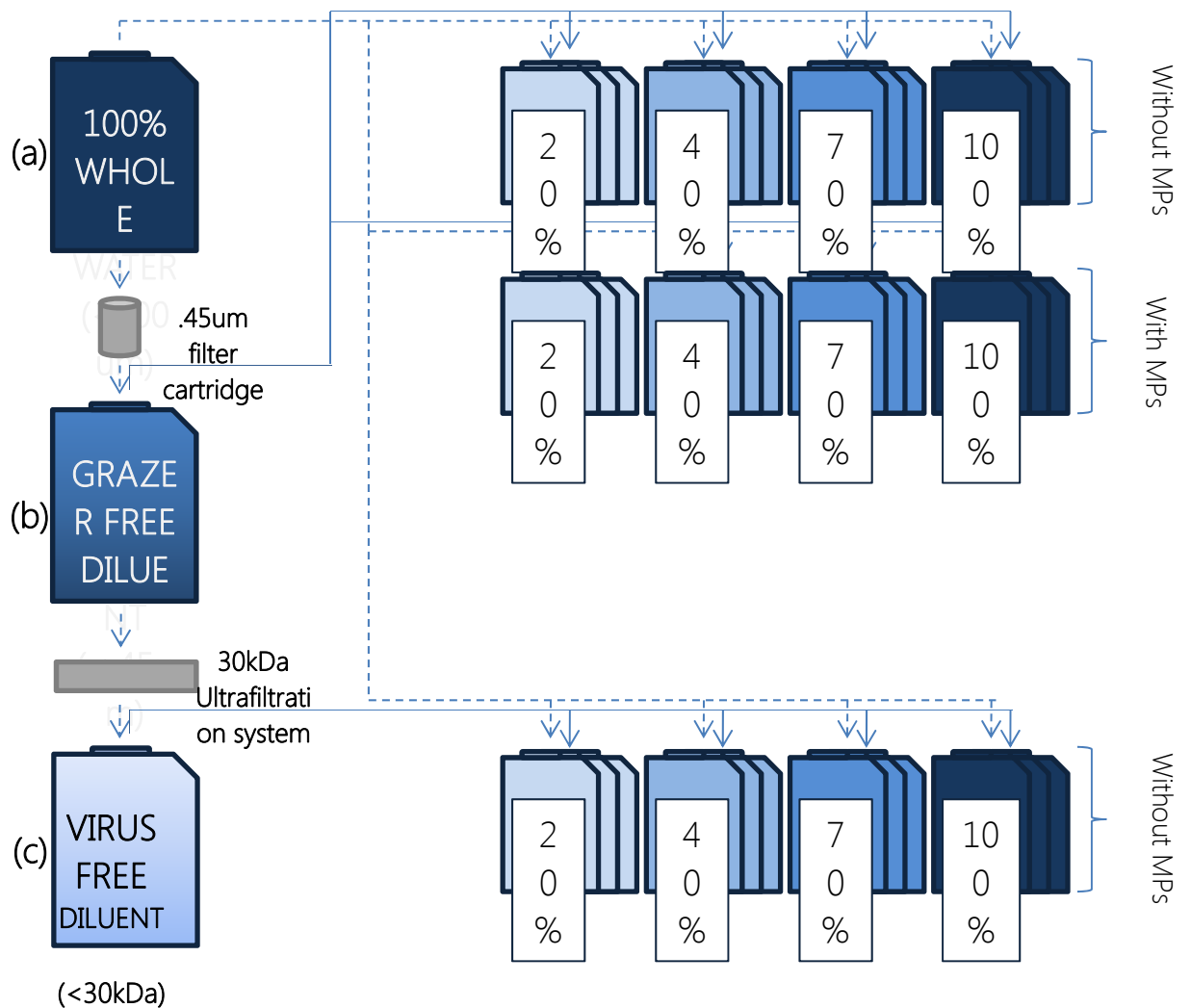


Fig. 48 Schematic of the set up used per dilution experiment (a) Mesoplankton-free whole water is combined with (b) $<.45\mu\text{m}$ filtrate and (c) $<30\text{kDa}$ filtrate to create a series of dilutions with progressively reduced grazing mortality only and both grazing and viral mortality, respectively. Two sets of dilutions are prepared with the $<.45\mu\text{m}$ filtrate; one set supplemented with $1\mu\text{m}$ polystyrene beads and one set without.

The experiment was set up according to the protocol by Evans et al. (2003). Approximately 50L of sampled sea water was filtered through a clean 200 μ m mesh (to remove mesoplankton) followed by a .45 μ m cartridge filter into a clean 20L polycarbonate (PC) carboy to prepare the grazer-free diluent. The diluent was then gently transferred into 1L PC bottles at the appropriate volumes and topped up with mesoplankton-free water to create two identical dilution series of 20%, 40%, 70%, and 100% whole water, each in triplicates. To one of the two series, 1 μ m polystyrene beads resuspended in filtered sea water were added at a concentration of approximately 2.3mg/L (**Fig.1**).

A parallel dilution series was set up using virus-free water which was prepared by running grazer-free diluent through a 30kDa filter via tangential flow filtration. All materials used, including rubber tubing, carboys, and PC bottles, were rinsed between every experiment with 10% HCl, MilliQ water, and filtered sea water (200 μ m). For the purpose of determining viral and grazer concentrations at each dilution level, small volumes of both diluents were fixed in 0.5% glutaraldehyde, flash frozen with liquid nitrogen, and stored at -80°C. A subsample of whole water was also fixed in 20% paraformaldehyde (PFA) and frozen for subsequent fluorescence in situ hybridization (FISH) analysis. Each experiment was conducted in a constant temperature lab (12°C) with low lighting.

PC bottles were then incubated for 24 hours in a clear acrylic tank which was connected to a steady supply of seawater and lined with light screens to simulate *in situ* conditions.

Sub-samples were collected for each dilution level at T0 (pre-incubation) and T24 (post-incubation) for composition and abundance analyses.

3. *Community composition and abundance*

Cell counts were carried out using a Becton Dickinson FACSCalibur flow cytometer. With the addition of fixatives, tripotassium citrate and 20% PFA, and an internal standard of 1 μ m beads, phytoplankton composition and abundance was analyzed at high flow rate (161 μ l/min) and were discriminated on the basis of side scatter and chlorophyll fluorescence. Non-phototrophic bacteria were analyzed similarly but with the addition of SYBR Green I at a low flow rate (11 μ l/min) and the discriminator set to green fluorescence.

Measurements were made using the software CellQuestPro and dot-plots of side scatter versus chlorophyll or green fluorescence were used to identify different bacterial groups.

4. *Growth and mortality*

High growth rates were observed throughout most of the experiments. However, new production was generally balanced by consumption by grazing and no viral lysis could be detected (refer **Table 1**). Consequently, the <30kDa fraction of the experiment was removed as the filtration process was too slow and consequently interfered with the incubation times of the other portion of the experiments.

Challenges were faced, however, in attempts to produce statistically significant data with the MP incubations due to several factors. Initially, incubations were to be inoculated with dry, 1-4 μ m clear polyethylene spheres suspended in small volumes of MilliQ water. However, the beads did not remain in solution and separated too heavily in order to obtain a standard concentration per incubation bottle. Alternatively, 1 μ m polystyrene beads pre-suspended in thimerosal, an established antimicrobial and antifungal agent, were used. In order to clean the beads of the solution, they were filtered on two separate attempts—once and three times, respectively—through a 0.2 μ m Swinnex unit and back flushed with 0.45 μ m filtered seawater to recover as much of the beads as possible. However, both attempts were not successful in completely removing the solution and suppressed the growth of the microbial populations.

Table 10 Sample data of apparent growth rates of the major bacterial groups from Experiment 3 (Syn = *Synechococcus sp.*, Euk = Eukaryotic group, LNA = low nucleic acid, HNA = high nucleic acid) in the presence and absence of microplastics (MPs).

Fraction	Dilution Level	Apparent growth rate ($\mu \text{ d}^{-1}$)			
		Syn	Euk	LNA	HNA
Whole water	1	0.39449	0.09248	0.22352	0.48358
	1	0.07408	0.03291	0.39096	0.76874
	1	-0.0007	-0.075	0.22988	0.54473
<0.45 μm (without MPs)	0.7	0.16211	0.0678	-0.057	0.47473
	0.7	0.07102	0.02987	-0.1012	0.45673
	0.7	0.08381	-0.1107	-0.0176	0.38213
	0.4	1.09232	1.01252	0.0648	1.01573
	0.4	0.48966	0.50965	0.30266	0.92643
	0.4	0.05472	0.05372	0.32397	0.57999
	0.2	0.51791	0.26589	0.1111	0.70827
	0.2	0.7646	0.58424	0.02386	0.434
	0.2	0.81469	0.73555	0.03832	0.73952
<0.45 μm (with MPs)	1	-0.0091	-3.7126	-0.1618	-0.2357
	1	-0.0772	-3.0548	-0.0974	-0.3742
	1	-0.1185	-3.1804	-0.2526	-0.3442
	0.7	-0.0323	-3.0798	-0.1609	-0.2738
	0.7	-0.1573	-2.95	0.01335	-0.1827
	0.7	-0.0491	-3.068	-0.1386	-0.2054
	0.4	-0.1515	-2.669	-0.1323	-0.2318
	0.4	-0.0256	-2.781	0.059	-0.0344
	0.4	-0.0814	-1.7786	-0.609	-0.5543
	0.2	0.1329	-1.6162	-0.3581	0.06333
	0.2	-0.1485	-1.2215	-0.293	0.10994
	0.2	0.08755	-0.9104	-0.1187	0.02362

18 Molecular Ecology

Rob Young

Samples for genetic work were collected from the megacore, CTD, snow catchers, and trawl for genetic processing. A total of seven megacores were sampled on this cruise for genetic studies (Table 1). All megacore samples were sectioned by 1cm intervals up to 5cm and frozen at -80C. This cruise, a benchtop autoclave was used to sterilize spatulas and slicing plates. The 1cm ring was bleach sterilized, as onboard experimentation revealed that this accouterment is, indeed, not autoclave compatible (Supp. Fig. 1). Additional material from the 0-1cm and 1-2cm sections were preserved in RNALater and frozen at -80C. Minisart cartridge filters (0.2um) were borrowed for filtering near bottom water with a peristaltic pump system that was sterilized between uses. Twelve samples were filtered from CTD casts (1.5L for all samples except those noted in Table 2 as 3L from station 085), preserved in RNALater, and frozen at -80C. The sampling design was near bottom (approx. 10m), 50m altitude, 100m altitude, and 4000m depth. Due to a 35m altimeter offset, the samples from DY077-007 were not sampled at these approximate target depths. The actual depths including the offset are given in Table 1. Particle samples from the snow catchers were preserved by M. Iverson in RNALater and frozen at -80C for comparison of genetic results with his group's FISH data. Table 1 summarizes all stations for megacore, snow catcher, trawl, and CTD samples taken during the cruise.

Table 1: Stations sampled for Molecular Ecology studies.

Station	Gear	Date	Time	Latitude	Longitude	Depth (m)
DY077-007	CTD	17/04/201 7	00:31	49 3.26	16 20.37	4749, 4709, 4659, 3962
DY077-016	MgC08+2	17/04/201 7	19:01	48 50.246	16 31.199	4845
DY077-020	MgC08+2	18/04/201 7	20:00	48 50.431	16 31.095	4845
DY077-021	MgC08+2	19/04/201 7	00:06	48 50.038	16 31.542	4844
DY077-044	MSC	20/04/201 7	20:30	48 59.209	16 28.203	350
DY077-045	MSC	20/04/201 7	20:52	48 59.21	16 28.202	200
DY077-048	CTD	20/04/201 7	22:10	48 58.129	16 28.075	4822, 4782, 4736, 3998
DY077-053	MSC	21/04/201 7	10:30	49 11.287	16 42.029	40
DY077-056	MgC08+2	22/04/201 7	09:36	48 50.309	16 31.449	4844
DY077-057	MgC08+2	22/04/201 7	13:47	48 50.225	16 31.686	4844
DY077-059	OTSB14a	23/04/201 7	01:00	48 55.1	16 41.1	4843
DY077-065	MgC08+2	24/04/201 7	05:23	48 50.363	16 31.288	4844
DY077-085	CTD	25/04/201 7	14:19	48 59.329	16 23.733	4822 (3L), 4782 (3L), 4736 (3L), 3998
DY077-086	MgC08+2	25/04/201 7	22:34	48 50.308	16 31.224	4843
DY077-102	OTSB14a	27/04/201 7	15:28	48 50.727	16 40.515	4840

Whole organism or tissue samples were taken mainly from the trawl. A single tissue sample from an unknown organism was taken from a megacore (DY077-065-cry-1) as it (curiously) shot out of a burrow while we raised the core tube. Table 2 summarizes tissue and whole organism samples taken during the cruise. Thirteen samples of holothurians (comprising seven different genera) were sampled for microbiome work. These samples include both gut contents and host tissue for species confirmation (Figures 1-3). Tissue samples were taken from various additional organisms coordinated with the photos for the photographic manual (noe- IDs). Other organisms sampled include *Bathysaurus* sp. (Figure 4), a cephalopod (not pictured), and polychaetes (not pictured; they collectively weigh 11.6g, in case this interferes with metabolic theory). Three parasitic snails were found (two different species), believed to be Eulimids (Figures 5-7).



Figure 1: *Molpadiodem vilosus* microbiome samples (DY077-059-cry-3 through DY077-059-cry-7)



Figure 2: *Deima validum* microbiome samples (DY077-059-cry-2 and DY077-059-cry-8)



Figure 3: *Paroriza prouhoi* (DY007-102-cry-12 and DY007-102-cry-13)



Figure 4: Tissue taken from tail of *Bathysaurus* sp. (DY007-102-cry-2)



Figure 5: *Pseudostichopus aemulatus* host (DY077-102-cry-11) from which parasitic snail was taken (DY077-102-cry-1)



Figure 6: Eulimid parasitic snail (DY077-102-cry-1) from *Pseudostichopus aemulatus*



Figure 7: Sample from which host (*Oneirophanta mutabilis*), microbiome, and parasitic snail were sampled (DY007-102-cry-3 through DY007-102-cry-6)

ID	Gear	noe-ID	Organism	Comments
				EtOH, RNA Later, frozen -80C (all 1.5ml eppendorf); large individual unknown species
DY077-059-cry-1	OTSB14	n.a.	cephalopod	
DY077-059-cry-2	OTSB14	noe-08	<i>Deima validum</i> <i>Molpadiodemas</i>	foregut and hindgut frozen -80C (2 x falcon tubes)
DY077-059-cry-3	OTSB14	n.a.	<i>vilosus</i> <i>Molpadiodemas</i>	portion gut intact, body wall and gut frozen -80C (falcon tube) gut not intact; used sterile spatula to transfer gut contents to falcon tube, body wall and gut frozen -80C
DY077-059-cry-4	OTSB14	n.a.	<i>vilosus</i> <i>Molpadiodemas</i>	
DY077-059-cry-5	OTSB14	n.a.	<i>vilosus</i> <i>Molpadiodemas</i>	gut intact; body wall and gut frozen -80C gut intact; good transfer, no likely contamination; body wall and gut frozen -
DY077-059-cry-6	OTSB14	n.a.	<i>vilosus</i> <i>Molpadiodemas</i>	80C
DY077-059-cry-7	OTSB14	n.a.	<i>vilosus</i>	gut intact; good transfer; body wall and gut frozen -80C
DY077-059-cry-8	OTSB14	noe-14	<i>Deima validum</i>	gut and host sample
			mixed	
DY077-059-cry-9	OTSB14	n.a.	holothurians*	EtOH
DY077-065-cry-1	MgC	n.a. noe-67	unknown tissue from burrow; this megacore had a burrow throughout the core	
DY077-102-cry-1	OTSB14	(host)	parasitic snail*	Eulimid? falcon tube EtOH
DY077-102-cry-2	OTSB14	noe-72 noe-70	<i>Bathysaurus</i> sp.	tail tissue taken; falcon tube EtOH
DY077-102-cry-3	OTSB14	(host)	parasitic snail*	Eulimid? Whole snail with host tissue attached; falcon tube EtOH

DY077-102-cry-4	OTSB14	noe-70	<i>Oneirophanta mutabilis</i> <i>Oneirophanta mutabilis</i>	foregut contents; -80C (whirlpack)
DY077-102-cry-5	OTSB14	noe-70	<i>mutabilis</i> <i>Oneirophanta mutabilis</i>	body wall tissue; falcon tube EtOH
DY077-102-cry-6	OTSB14	noe-70	<i>mutabilis</i>	hindgut; falcon tube EtOH
DY077-102-cry-7	OTSB14	noe-73 noe-74	<i>Benthotydes lingua</i>	tissue; falcon tube EtOH
DY077-102-cry-8	OTSB14	(host)	parasitic snail* <i>Oneirophanta mutabilis</i>	eulimid? falcon tube EtOH
DY077-102-cry-9	OTSB14	noe-74	<i>mutabilis</i>	tissue; falcon tube EtOH
DY077-102-cry-10	OTSB14	noe-82	shrimp	leg; falcon tube EtOH
DY077-102-cry-11	OTSB14	noe-67	<i>Pseudostichopus aemulatus</i>	tissue; falcon tube EtOH
DY077-102-cry-12	OTSB14	noe-81	<i>Paroriza prouhoi</i>	gut contents; frozen -80C (whirlpack)
DY077-102-cry-13	OTSB14	noe-81	<i>Paroriza prouhoi</i>	gut tissue (host); frozen -80C (whirlpack)
DY077-102-cry-14	OTSB14	noe-90	holothuroidea <i>Pseudostichopus aemulatus</i>	Paroriza?; gut contents and tissue; potentially not aseptic; frozen -80C (in same whirlpack)
DY077-102-cry-15	OTSB14	noe-88	<i>aemulatus</i>	gut contents; potentially not aseptic; frozen -80C (whirlpack)
DY077-102-cry-16	OTSB14	noe-93	<i>Molpadia blakei</i>	gut contents; potentially not aseptic; frozen -80C (whirlpack)

DY077-102-cry- 18	OTSB14	n.a.	polychaetes	laetmonice? n=7; frozen in bulk; 11.6g total; frozen -80C (whirlpack)
----------------------	--------	------	-------------	---

*Table 2: Tissue and whole organism samples preserved in 95% EtOH or frozen at -80C. Bold denotes samples taken for microbiome analysis. *Samples taken for collaboration with Greg Rouse (SCRIPPS Institute of Oceanography) on deep holothurian host phylogeny and parasite phylogeny in conjunction with the microbiome studies. Noe-ID is the corresponding ID on tag with specimen from Noele's photos; n.a. denotes samples for which no corresponding ID exists.*

19 PELAGRA Cam, HoloCam, In-situ Camera, and Marine Snow Catcher

Morten Iversen, Christian Konrad, Kev Saw, Richard Lampitt

19.1 PELAGRA Cam

We deployed the PELAGRA Cam in the upper water column to determine the abundance and size-distribution of particles larger than $\sim 100 \mu\text{m}$. We deployed the PELAGRA Cam both as a profiling system to capture an image of the particles in the upper 300 m of the water column at five seconds intervals and as neutrally buoyant systems on the PELAGRA sediment traps. The PELAGRA Cam was timed to take ten images with two seconds intervals every 30 minutes while on the PELAGRA sediment traps. While it is difficult to determine if a particle is settling or suspended from the images obtained with the profiling system, the PELAGRA sediment trap deployments offers the opportunity to determine settling velocity of the particles in situ, as well as estimating the proportion of settling versus suspended particles. Further, due to the high resolution of illumination of the PELAGRA cams, it is possible to determine particle types and colours and thereby quantify abundance and size-distribution of different particle types (e.g. marine snow versus zooplankton faecal pellets). Finally, we can determine size-specific settling velocities of individual particles from the deployments on the neutrally buoyant PELAGRA sediment traps.

The PELAGRA Cam consisted of a Canon EOS 6D digital SLR camera equipped with a 50 mm macro lens and a Canon Speedlite 600EX RT flashgun. The camera and the flashgun were placed perpendicular to each other provide illumination from the right side of the captured images (see Fig. 1). We used a Hahnel Giga T Pro II remote timer to capture an image every five seconds. The camera was put in manual mode and the settings were adjusted to have an ISO of 2500, a shutter speed of 1/160 seconds, an aperture of f/32, and the lens focus was put to 1.5 feet. The flash was also in manual mode and put for straight flash direction and a flash output of 1/8.

We were able to capture individual particles through the water column in a water volume of 2.15 L for each captured image. The pixel size of the images changed depending on whether the particles were in the front or back of the field of depth. We determined a pixel size of $33 \mu\text{m}$ per pixel in the front of the depth of field (as seen from the camera) and a pixel size of $61 \mu\text{m}$ per pixel at the back of the depth of field. This suggested an average pixel size of $47 \mu\text{m}$ per pixel. The field of view for each image was 157 mm width, 101 mm height, and 135 mm depth. The width and height of the images were determined by the cropping of each image to compensate for uneven flash illumination and might change when we do the final image processing.

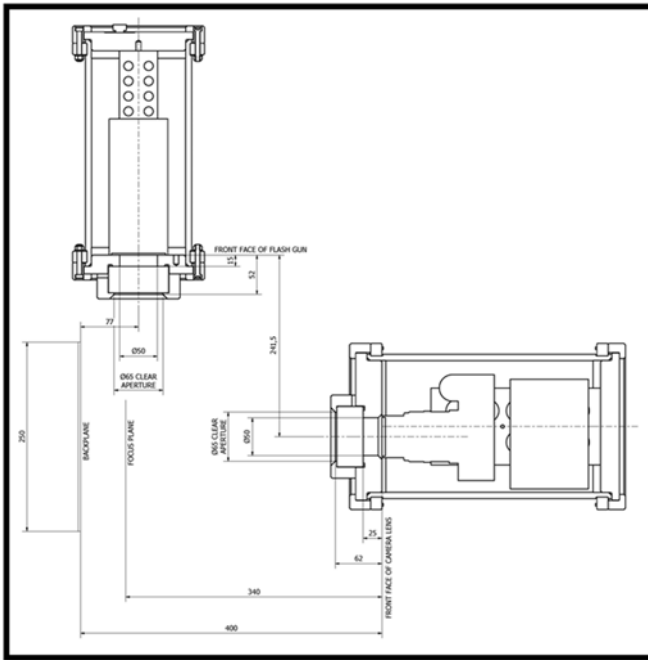


Fig. 1. Overview figure of the PELAGRA Cam configuration. The pressure housing in the lower right part of the image contained the camera and the upper left pressure housing contained the flashgun.

19.2 The Red Camera Frame (RCF)

The PELAGRA Cam deployments were done as vertical profiles on the Red Camera Frame (RCF) in combination with the LISST HOLO (Holocam). The Holocam captured images every five seconds, which was the same frequency as the PELAGRA Cam. We made 4 vertical profiles with the RCF from the surface to 300 m depth (see Table 1), whereby the profiles 1 to 3 were only deployed with the Holocam and the last profile was done with Holocam, the PELAGRA Cam and a Star-ODDi CTD with a measure interval of 1 sec.



Fig. 2. The Red Camera Frame (RCF) with the PELAGRA Cam and the LISST HOLO (Holocam).

19.3 The In-Situ camera

The particle camera (ISC) is an infrared camera with backlight infrared illumination that can be used to investigate particle size and abundances in the water column (Fig. 3). It is equipped with a CTD with oxygen, turbidity, and fluorescence sensors that allow us to link the vertical distribution and abundance of particles to the water column properties (Fig. 4). We made 13 deployments with the ISC.

The camera unit consists of a four megapixel industrial camera with a fixed focal length lens and a single board computer and further hardware to be able to perform automated image acquisition during the deployments. The lightsource is a custom made infrared illumination which is triggered by the camera unit. A DSPL battery is providing power to the system. All these parts are mounted together with a Seabird SBE19 CTD on a frame for deployments with various ships winch systems. The arrangement of the system has a pixel size $20\mu\text{m}$ and a FoV of $36 \times 24 \text{ mm}$ with a depth of 24 mm , resulting in a volume of 20.7 ml per image.

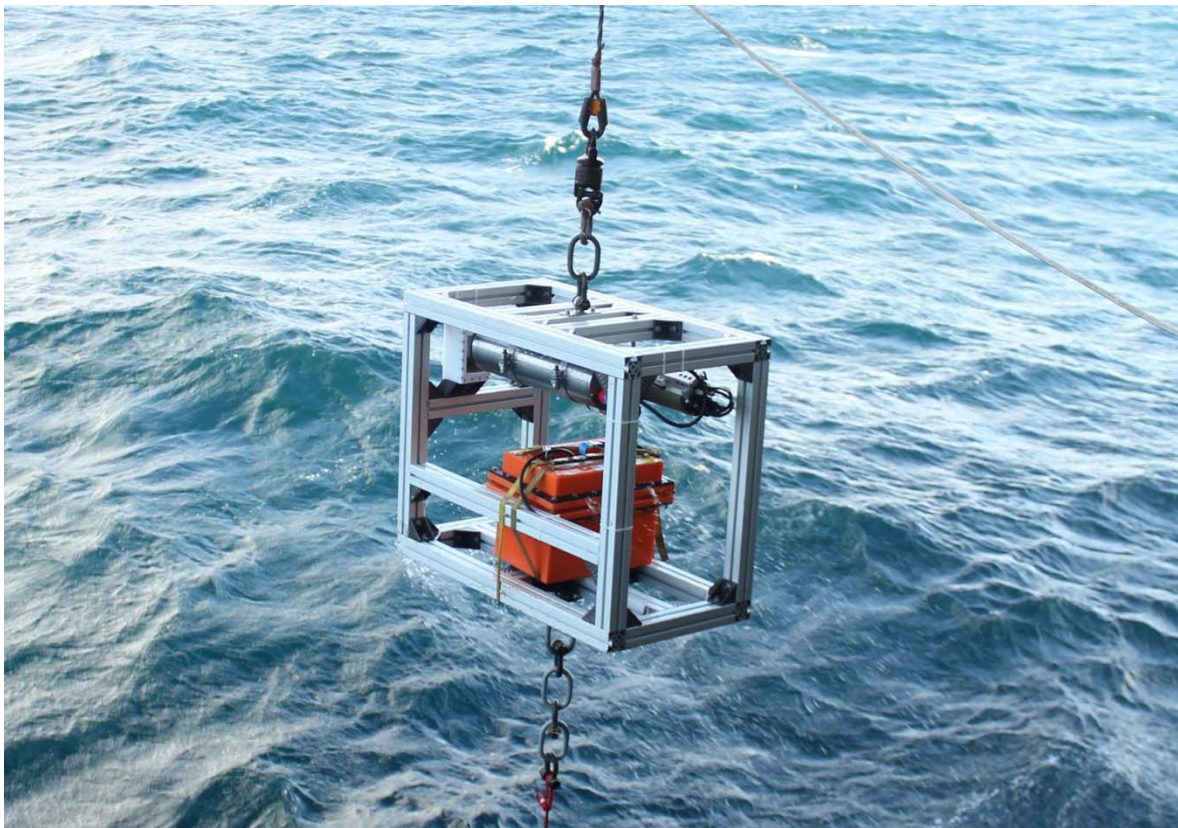


Fig. 3. The In-Situ Camera (ISC) during deployment. The camera housing mounted at the front of the upper part of the frame with the CTD behind it and the light source to the left. The orange battery housing placed in the lower part of the frame.

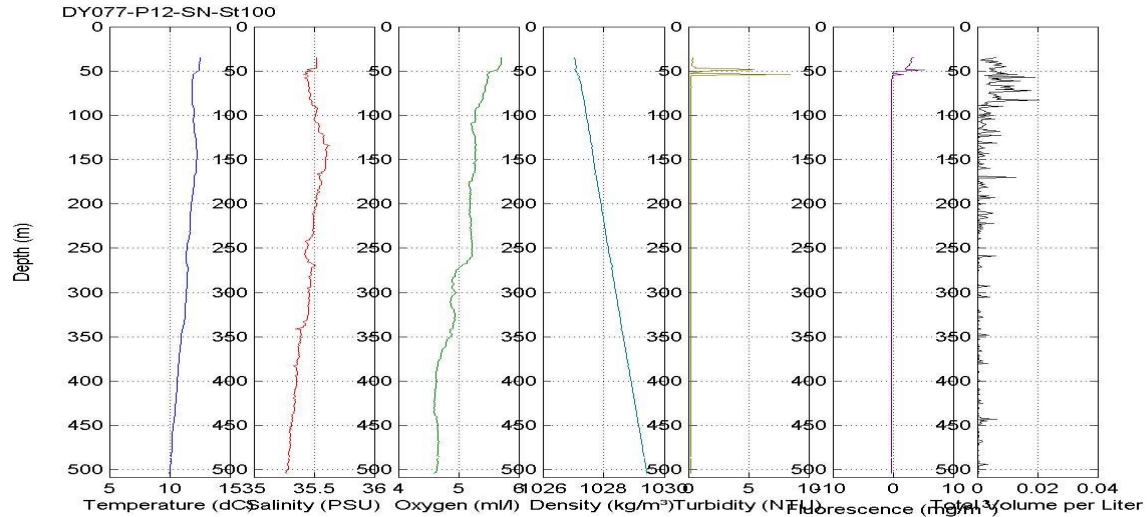


Fig.4: Total aggregate volume and CTD raw data of profile #12 (St100) as an example of the results obtained with the ISC.

19.4 Marine Snow Catcher

During the Discovery cruise, DY050, one subgroup of the scientific party studied export processes in the water column. This work included comparisons of different trapping devices to quantify vertical export of matter (see Drifting trap section) and vertical camera profiles to determine the abundance and size-distribution of particles and aggregates at different depths (see In-Situ Camera section). To have a closer look at the composition of individual, in situ-formed aggregates we deployed marine snow catchers to collect settling aggregates.

The marine snow catchers consist of a 100 l cylindrical water sampler and a particle collection tray from where the particles can be sampled after they have been allowed to settle for a few hours (Fig. 5). We collected settling aggregates in parallel to the drifting trap deployments and at the depth of the traps and from 10 m below the depth of fluorescence maximum (Table 1). Additionally, we used the marine snow catchers to collect water from 350 m to make the brine solution for the first drifting trap deployment.



Fig. 5: Recovery of a marine snow catcher during the DY077 cruise. Another marine snow catcher is seen lying on deck. After placing the marine snow catcher upright for a period of time, the aggregates will settle out and can be collected from the lower, detachable part of the marine snow catcher.

Individual aggregates from each collection depth were observed under an inverted bright-field microscope at magnifications between 100x and 400x. We made stacked images to obtain a good three dimensional perspective of each aggregate. Some of the aggregates were stained with a dye the binds to polysaccharides within the aggregates. The microscopic investigations of the particles collected with the MSC showed aggregates dominated by degraded faecal pellet fragments throughout the whole water column during the first drifting trap deployment. During the second drifting trap deployment, the aggregates in the upper water column were very porous and fragile aggregations of pennate and chain-forming diatoms. These porous aggregates had very low sinking velocities and remained suspended for long periods of only slight disturbances of the water in the lower part of the marine snow catcher (*Fig. 6*).


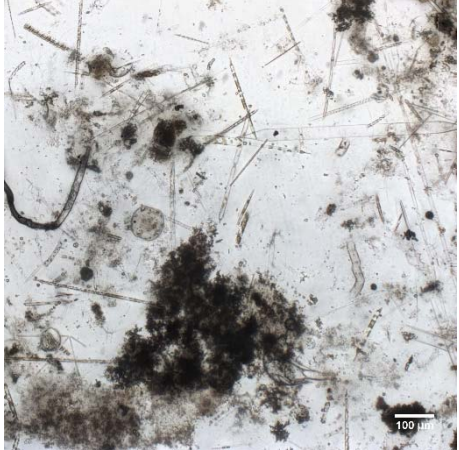
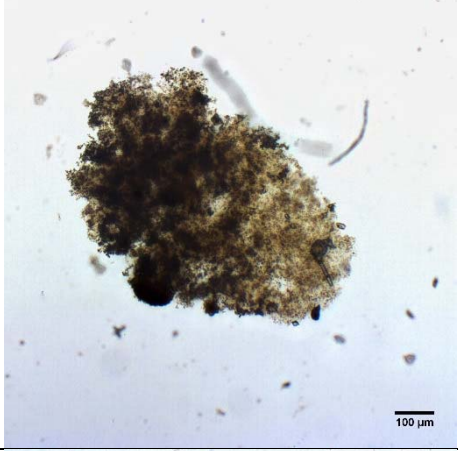
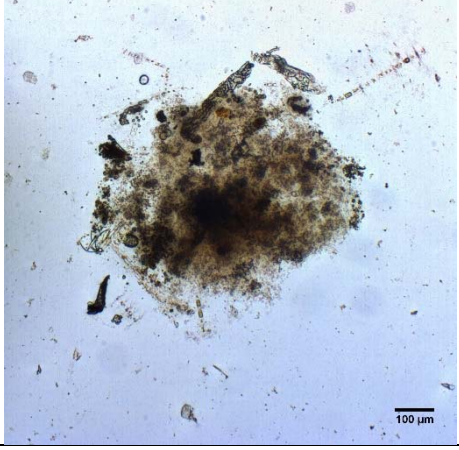
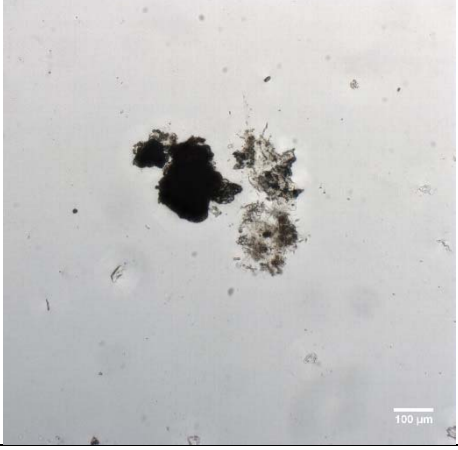
Depth (m)	1 st drifting trap deployment	2 nd drifting trap deployment
10 m below fluorescence maximum		
200 m		<i>No sample taken since no trap deployments were done at this depth.</i>
350 m		

Fig. 6. Examples of aggregates collected with the marine snow catcher at different depths through the water column. During the second deployment we did not observe any defined aggregates 10 m below the fluorescence maximum, but only very porous and fragile coagulations of pennate and chain-forming aggregates.

Table 1. Overview of deployments of the Red Camera Frame (RCF), In-Situ Camera (ISC), and the Marine Snow Catchers (MSC). Station number (Stat. No) is the ship's station number. The profile numbers are provided for each of the three instruments. The depth is the maximum depth that the cameras were deployed to and the depth where the marine snow catchers were closed. See the full station list at the end of the reports for positions of the different deployments.

Stat. No	MSC	RCF	ISC	Date	Time	Profile No	Depth (m)
St002	Y			16/04/17	20:40	MSC1	350
St003	Y			16/04/17	21:34	MSC2	350
St004	Y			16/04/17	22:03	MSC3	350
St006	Y			16/04/17	22:41	MSC4	350
St032			Y	19/04/17	10:39	ISC1	400
St034			Y	19/04/17	13:34	ISC2	400
St036			Y	19/04/17	16:21	ISC3	400
St037		Y		19/04/17	16:50	RCF1	300
St041			Y	20/04/17	15:40	ISC4	400
St043		Y		20/04/17	19:30	RCF2	300
St044	Y			20/04/17	20:20	MSC5	350
St045	Y			20/04/17	20:52	MSC6	200
St046	Y			20/04/17	21:12	MSC7	40
St047	Y			20/04/17	21:23	MSC8	40
St050			Y	21/04/17	06:40	ISC5	500
St052			Y	21/04/17	10:00	ISC6	600
St053	Y			21/04/17	10:34	MSC9	40
St054	Y			21/04/17	10:47	MSC10	40
St076			Y	24/04/17	14:30	ISC7	500
St080			Y	24/04/17	22:06	ISC8	400
St081			Y	24/04/17	23:46	ISC9	400
St090			Y	26/04/17	13:02	ISC10	500
St092	Y			26/04/07	14:55	MSC11	350
St093	Y			26/04/07	15:22	MSC12	350
St094	Y			26/04/07	15:53	MSC13	40
St095			Y	26/04/17	16:01	ISC11	500
St096	Y			26/04/17	16:07	MSC14	40
St098		Y		26/04/17	18:10	RCF3	300
St100			Y	26/04/17	21:51	ISC12	500
St103			Y	28/04/17	06:42	ISC13	500
St104		Y		28/04/17	07:43	RCF4	300

19.5 PELAGRA Cam and gel traps on the PELAGRAS

We deployed the PELAGRA Cam on the PELAGRAS two times (Fig. 7) on P4 and P7. The first deployment (P4 deployment 1) was under-ballasted and never made it to depth (see Cruise Report on the PELAGRAS). Both deployments on P7 and the second deployment on P4 provided well illuminated images with particles in focus, which will be used to determine particle size distributions as well as size specific settling velocities.



Fig. 7. PELAGRA with the PELAGRA Cam mounted (the two green pressure housings). The left side pressure housing is for the camera and the right side pressure housing is for the flashgun.

The PELAGRA cameras captured an image sequence of 10 images every hour during the deployments. We will use these sequences to determine the size-distribution, abundance, and size-specific sinking velocities of the sinking aggregates during the deployment periods for the PELAGRAS.

20 BioOptical Platform

Christian Konrad, Richard Lampitt, Morten Iversen

We developed a new method to follow dynamics of individual sinking aggregates during long-term deployments (here for one year) by combining in situ optics with gel traps. The BioOptical Platform (BOP) uses an optical system to determine size-distribution, abundance and size-specific sinking velocities of settling particles every day throughout a whole year. Additionally, it collects the settling particles in a viscous gel over different time intervals throughout the year. The BOP system is based on a modified sediment trap (Fa. KUM GmbH) where we have replaced the collection funnel with a polycarbonate cylinder to avoid that the settling particles are sliding down the sides of the funnel,

which would change the physical structure. The polycarbonate cylinder has an inner diameter of 35 mm and functions as a settling column and allows us to measure the settling velocities and sizes of the particles without interference from ocean currents (Fig. 1). This is done with a camera system that is placed at the lower part of the settling column. The camera system consists of an industrial camera (Fa. Basler), a fixed focal length lens (Fa. Edmund Optics) and the system electronics consisting of single board computer including a SSD hard disc and custom made power and time management circuitry. The images are illuminated by a custom made visible light source providing backlight. The whole camera system is powered by a Li-Ion battery (24V, 1670Wh, Fa. SubCTech GmbH) (2). The camera system makes 5 min of recordings every day. Once the particles have settled through the settling column they are collected in cups filled with a viscous gel that preserves their size and physical structure. The gel cups are placed on two rotation tables capable of carrying 40 gel cups (Figure 20).

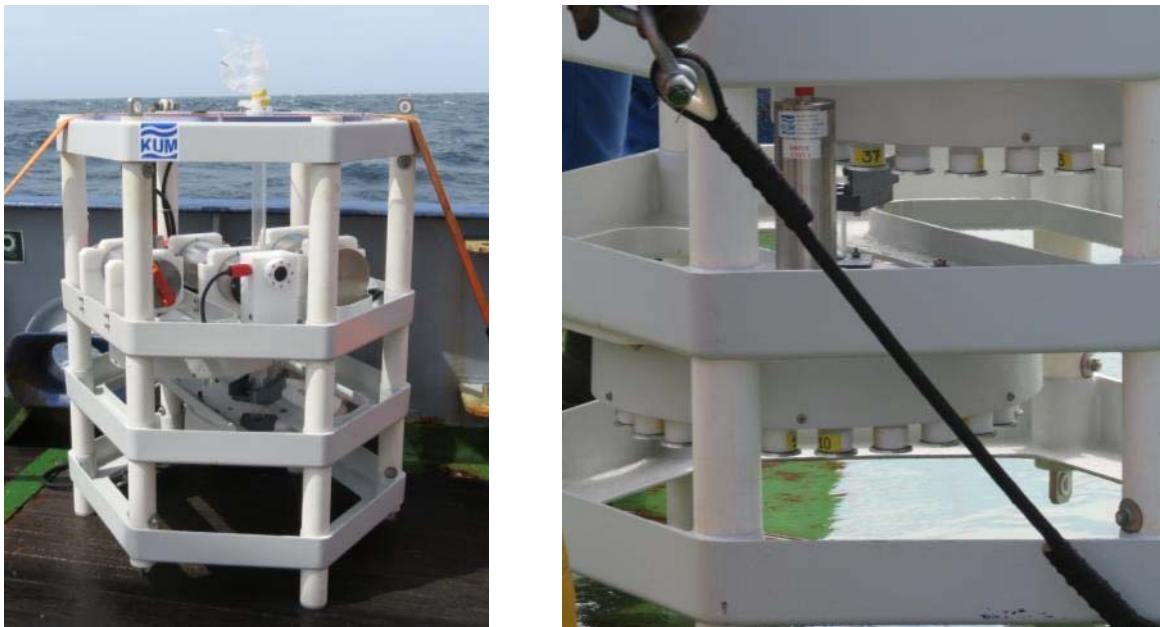


Figure 20: The BOP system with the polycarbonate settling column (left image) and the two rotation tables (right image).



Figure 2: Camera System on BOP with the camera housing (for camera, lens and system electronics), the VIS light source and the Li-Ion battery

System configuration, measurements and deployment and recovery

The geometrical configuration of the camera system enables daily recordings of shadow images of the particles within the settling column throughout a whole year. It was programmed to take one image per second for five minutes every day throughout one year.

The system was deployed as part of the PAP#3 mooring at 2930m during DY050. The recovery of BOP system on the PAP#3 mooring during this cruise was successful the system was in good shape and still in operation.

Due to a bug in the software of the power management system, the system lost its memory power and with that the timestamp after some app. 2 month after deployment. This resulted in the fact that the measurement stopped after 78 sequences of images. Nevertheless, a first check of the acquired image sequences showed several particles sinking in the settling cylinder.

The collection cups had all rotated and collected particles according to the assigned opening periods.

Table 20: Programming of the BOP system. Periodical measurements of the camera system for 5 minutes every day and changing of 40 gel cups in the sediment trap every 3 / 15.5 days alternately.

Date [YYYY-MM-DD]	Time [HH:MM:SS]	Remarks
2016-04-21	12:00:00	Camera: auto start, 1 image per second for 5 minutes, auto shutdown, THIS PROCEDURE WILL BE REPEATED EVERY DAY WITHOUT END DATE
2016-04-26	00:01:00	Trap: Next bottom bottle – 1
2016-05-12	00:01:00	Trap: Next bottom bottle – 2
2016-05-15	00:01:00	Trap: Next bottom bottle – 3
2016-05-18	00:01:00	Trap: Next bottom bottle – 4
2016-05-26	00:01:00	Trap: Next bottom bottle – 5
2016-05-29	00:01:00	Trap: Next bottom bottle – 6
2016-06-01	00:01:00	Trap: Next bottom bottle – 7
2016-06-12	00:01:00	Trap: Next bottom bottle – 8
2016-06-15	00:01:00	Trap: Next bottom bottle – 9
2016-06-23	00:01:00	Trap: Next bottom bottle – 10
2016-06-26	00:01:00	Trap: Next bottom bottle – 11
2016-06-29	00:01:00	Trap: Next bottom bottle – 12
2016-07-10	00:01:00	Trap: Next bottom bottle – 13
2016-07-13	00:01:00	Trap: Next bottom bottle – 14
2016-07-21	00:01:00	Trap: Next bottom bottle – 15
2016-07-24	00:01:00	Trap: Next bottom bottle – 16
2016-07-27	00:01:00	Trap: Next bottom bottle – 17
2016-08-07	00:01:00	Trap: Next bottom bottle – 18
2016-08-10	00:01:00	Trap: Next bottom bottle – 19
2016-08-28	00:01:00	Trap: Next bottom bottle – 20
2016-08-31	00:01:00	Trap: Next bottom bottle – NaN
2016-08-31	00:02:00	Trap: Next top bottle – 21
2016-09-18	00:02:00	Trap: Next top bottle – 22
2016-09-21	00:02:00	Trap: Next top bottle – 23
2016-10-09	00:02:00	Trap: Next top bottle – 24
2016-10-12	00:02:00	Trap: Next top bottle – 25
2016-10-30	00:02:00	Trap: Next top bottle – 26

2016-11-02	00:02:00	Trap: Next top bottle – 27
2016-11-27	00:02:00	Trap: Next top bottle – 28
2016-11-30	00:02:00	Trap: Next top bottle – 29
2016-12-25	00:02:00	Trap: Next top bottle – 30
2016-12-28	00:02:00	Trap: Next top bottle – 31
2017-01-22	00:02:00	Trap: Next top bottle – 32
2017-01-25	00:02:00	Trap: Next top bottle – 33
2017-02-26	00:02:00	Trap: Next top bottle – 34
2017-03-01	00:02:00	Trap: Next top bottle – 35
2017-04-02	00:02:00	Trap: Next top bottle – 36
2017-04-05	00:02:00	Trap: Next top bottle – 37
2017-04-23	00:02:00	Trap: Next top bottle – 38
2017-04-26	00:02:00	Trap: Next top bottle – 39
2017-05-17	00:01:00	Trap: Last bottle out; System open

We had timed the collection cups to be open for long periods during low flux and short periods during high flux. Therefore all gel cups contained enough sinking particles and aggregates to determine their size-distribution and abundance at different seasons, but still in low enough abundance to avoid overlapping aggregates (Fig. 3). Since the gel preserves the individual aggregates in their original shape and structure, we can determine the composition and porosity from each of the collection periods.

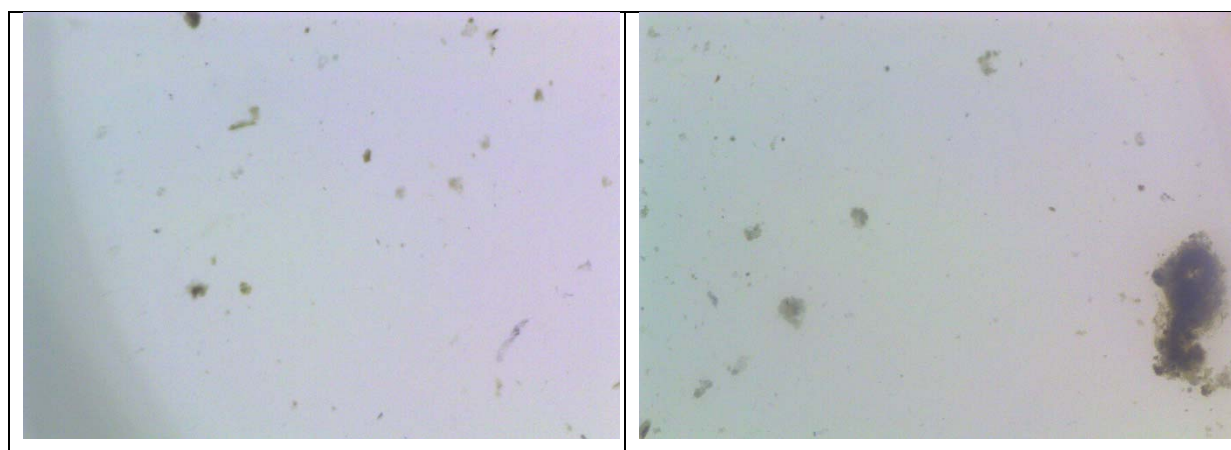


Fig. 3. The left image is from a gel cups the collected between 15th of May 2016 and 18th of May 2016. The right image shows particles collected in the period between the 5th of April 2017 and 23rd of April 2017.

21 PELAGRA

Kev Saw

The main purpose for including PELAGRA neutrally buoyant sediment traps on DY077 was to carry out comparisons with similar instruments, NBSTs, brought along by a team from Woods Hole Oceanographic Institute.

Four PELAGRA traps were on board: P4, P7, P8 and P9. P4 and P7 each carry two conventional sediment funnels, two non-funnelled collectors for gel sampling and a camera/flash system for capturing time-lapse images of sinking particles. P8 and P9 each carry four conventional sediment funnels.

Apart from having new batteries fitted in their APEX floats and general routine maintenance, P4, P7 and P8 were essentially unchanged from the previous PAP cruise, DY050. Changes to mass resulting from the new batteries were included in the ballast spreadsheets by calculation adjustment; these traps were not re-ballasted at NOC.

During last year's cruise, DY050, P8 failed to surface after its final deployment and was left behind, presumed lost. However, some four or five weeks after returning to Southampton, messages were received from P8 indicating it had re-surfaced. The trap was tracked drifting at the surface for a further six weeks or so before being recovered by the Royal Navy's HMS Scott. On inspection of the stored depth data it was clear that the trap had failed to drop its end-of-mission abort weight and lacked sufficient buoyancy to reach the surface. It therefore drifted at around 300 m depth for 10 days when it repeated its programmed mission (this is an inherent feature of the APEX float in the event that surface pressure is not detected and 'recovery mode' is not invoked). Eventually the abort weight was dropped (possibly due to natural corrosion of the burn wire) and the trap surfaced and began communicating. Subsequent tests revealed that the encoder on the carousel rotation motor had malfunctioned. This meant that the motor rotated continually on each power-up command until the programmed time-out was reached. The effect of this was that far more energy was drained from the batteries than would normally be the case and, because the same batteries power the burn wire, insufficient energy remained to burn the wire at the normal rate, if at all. The motor was replaced with a new unit for DY077 and tested OK.

P9 is a newly built trap and the opportunity was taken to try out some modifications. Previously the collection funnels have been manufactured from GRP but these had always proved to be quite fragile and would often crack when subject to impacts, e.g. against the ship's side on difficult recoveries. A method was therefore developed to manufacture the funnels from polypropylene sheet to take advantage of the impact toughness of this material. However, because polypropylene does not offer the same structural strength as GRP, the construction method was altered to clamp the funnels

between the upper and mid plates which meant re-configuring the lifting frame and introducing load carrying pillars such that the funnels carry no load on lifting. Additionally, a radar reflector was added high inside the lifting frame. The maximum diameter of the reflector was limited to the diameter of the upper float clamp so as not to shade the funnels and prevent sinking particles from entering. The reflector was painted in a high-visibility colour which meant the usual high-visibility flag could be omitted. Being fairly small and low to the water it was not certain that it would be effective. In the event the reflector proved to be ineffective and was not detected by the ship's radar except in calm, flat seas but in those near-perfect conditions the PELAGRA traps that didn't have reflectors were also detected in any case. The detection range was about 2 nm. In conclusion, a radar reflector offers no benefit and will not be included in future.

P9 and P7 were fitted with prototypes of a new iteration of the LED flashing light beacon. The new version uses the existing battery housing and pressure switch arrangement but with a new LED assembly comprising 6 COG LED strips mounted as a vertical hexagonal array. A new 'chaser' circuit was added to light each strip in turn such that only one strip was lit at any one time. This was to reduce power consumption and based on the fact that the observer (the ship) could only ever see one side of the light at any one time. To further reduce power consumption a 'daylight sensor' was added to switch the light off during daylight hours. The new lights worked very well and during night time recoveries were judged to be more visible than their existing counterparts. It is expected that the new light will be further refined and moved on to a 'production' version and ultimately become standard fitment for the PELAGRA traps.

21.1 Ballast trial deployment

It was intended that all four traps would be deployed for a short (18 hour) ballast trial on Monday 17 April. However, deck tests of the Iridium telemetry indicated a problem with the receiving server at NOC; without this server functioning it would be impossible to locate the traps for recovery and it was decided the trial deployment could not go ahead.

Several actions were taken in an attempt to rectify this situation however, this was hampered by the fact that this was Easter weekend and NOC was officially closed until 19 April. I initially contacted a colleague, Allison Schaap (OTEG), who kindly agreed to go to NOC and physically reboot the server and modem. This she did, but to no avail.

With thoughts that the problem may lie with the telephone line I managed to contact BT who tested the line and confirmed a fault. They later confirmed that a fault external to NOC had been repaired but a fault remained internal to NOC. To investigate this they would need access to NOC but this proved impossible as no out-of-hours cover was in place neither from NOC Estates nor from University of Southampton Telephony.

Late on Easter Monday night I contacted another colleague, Greg Slavik (OTEG), who kindly went to NOC and physically moved the server and modem to a new location in the building and connected to what was thought to be a different direct BT telephone line. Telemetry was re-tested but with no change. It was later discovered that this was in fact an extension from the same line that the server was previously connected to. The next day (still a NOC closure day), Greg went back to NOC and reconnected the server in its original location. Still the system was not functioning.

It was clear that with no reliable telemetry, no PELAGRA deployments would be possible. I therefore contacted Teledyne Webb Research (the APEX float manufacturer) in the US who kindly agreed to set our float IDs up on their server. This proved successful and this arrangement was used for the remainder of the cruise with all PELAGRA messages being emailed to myself and the PSO.

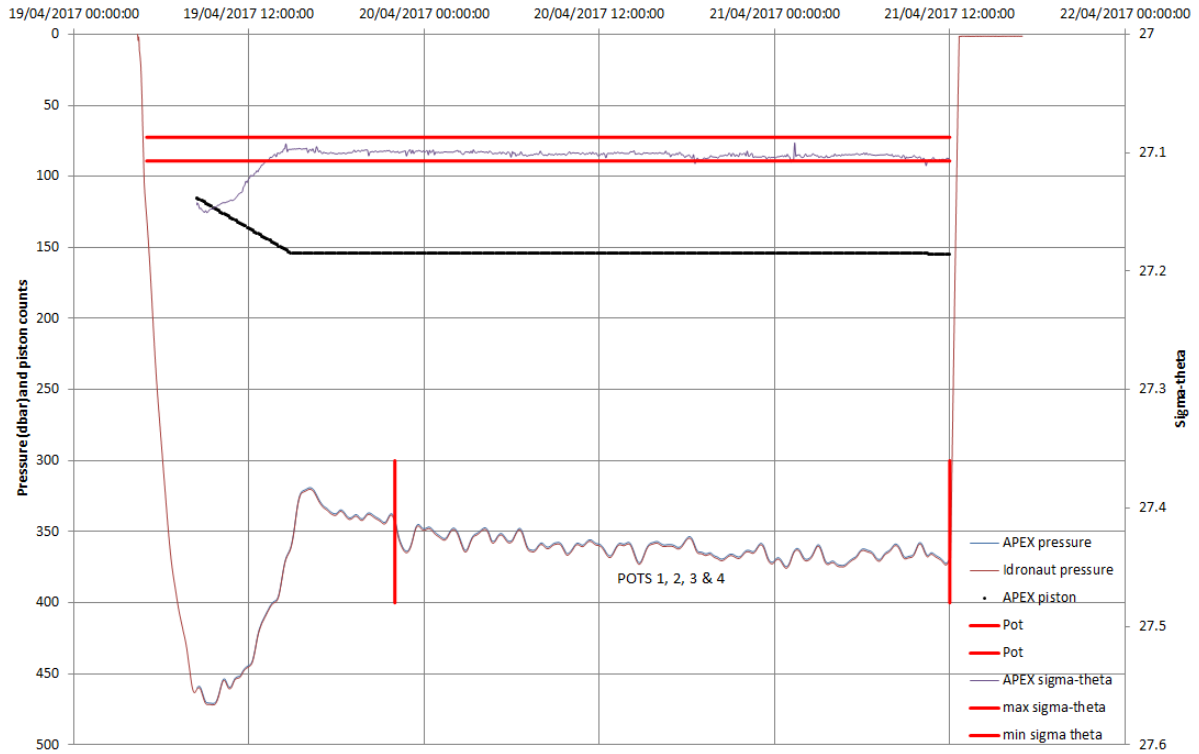
21.2 Deployment 1

All four traps were deployed with one camera trap and one standard trap deployed at each of two depths: 200m and 350m. All four camera trap sample cups (P4 and P7) were to be open for the full 38 hour collection period whereas the standard traps (P8 and P9) were to be open for two 19 hour consecutive periods arranged in opposite pairs (i.e. cups 1 and 3 open together followed by 2 and 4 open together). WHOI's NBSTs were to be deployed similarly for comparison although these sample tubes were open for the full deployment (deployed open).

P7 (camera trap)

Station:	DY077-022
Target depth:	350 m
Target temp:	11.151°C
In situ density:	1028.682 kg m ⁻³
Added ballast:	3303 g
Deployment time:	19.04.17 04:15
Deployment posn:	49° 58.86' N 16° 21.78' W

**P7 Deployment 1 - 19.04.17 - 350m
Station DY077-022**



As is evident from the above plot, P7 was over-ballasted and descended to 470 m before recovering to the intended 350 m. It did however successfully stabilise before the sample pots opened. The APEX buoyancy engine needed to increase displacement by 39 counts to achieve this suggesting that the trap was over-ballasted by c. 40 g.

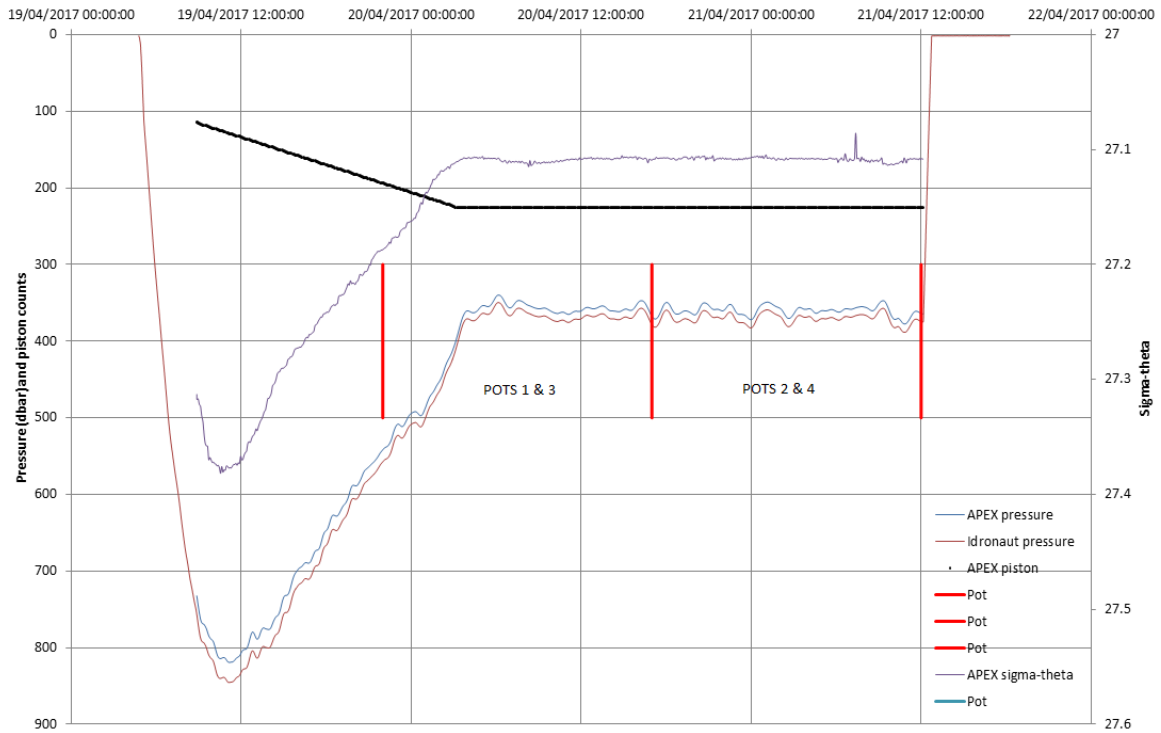
The depressor weight was released at 100 m as expected.

On recovery, all four sample pots had collected particles, the carousel was positioned as expected and the burn wire released at the expected time.

P9 (standard trap)

Station:	DY077-023
Target depth:	350 m
Target temp:	11.151°C
In situ density:	1028.682 kg m ⁻³
Added ballast:	3462 g
Deployment time:	19.04.17 04:30
Deployment posn:	49° 58.98' N
	16° 21.60' W

**P9 Deployment 1 - 19.04.17 - 350m
Station DY077-023**



P9 was over-ballasted and descended to 840 m before recovering to the intended 350 m, but not before the first sample pots opened. The APEX buoyancy engine needed to increase displacement by 111 counts (to its maximum extension of 226 counts) to achieve this suggesting that the trap was over-ballasted by c. 100 g.

The depressor weight was released at 100 m as expected.

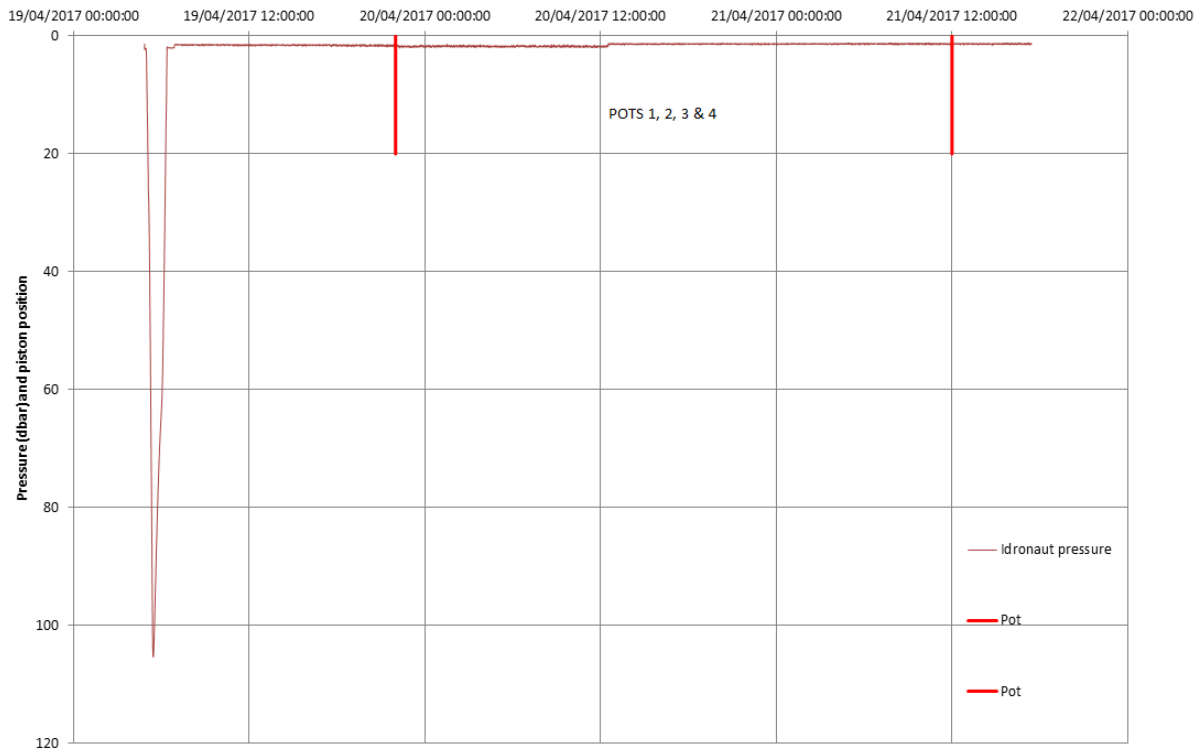
On recovery, all four sample pots had collected particles, the carousel was positioned as expected and the burn wire released at the expected time.

A clear offset between the APEX and Idronaut pressure sensors is evident from this plot. This will need to be investigated on return to NOC.

P4 (camera trap)

Station:	DY077-024
Target depth:	200 m
Target temp:	11.313°C
In situ density:	1027.995 kg m ⁻³
Added ballast:	3169 g
Deployment time:	19.04.17 04:45
Deployment posn:	49° 58.98' N
	16° 21.60' W

**P4 Deployment 1 - 19.04.17 - 200m
Station DY077-024**



P4 was under-ballasted and returned to the surface after the depressor weight had released at 100 m and quicker than the APEX could adjust to compensate. The APEX aborted and entered recovery mode. Nothing quantitative can be learned from this deployment regarding the ballasting error.

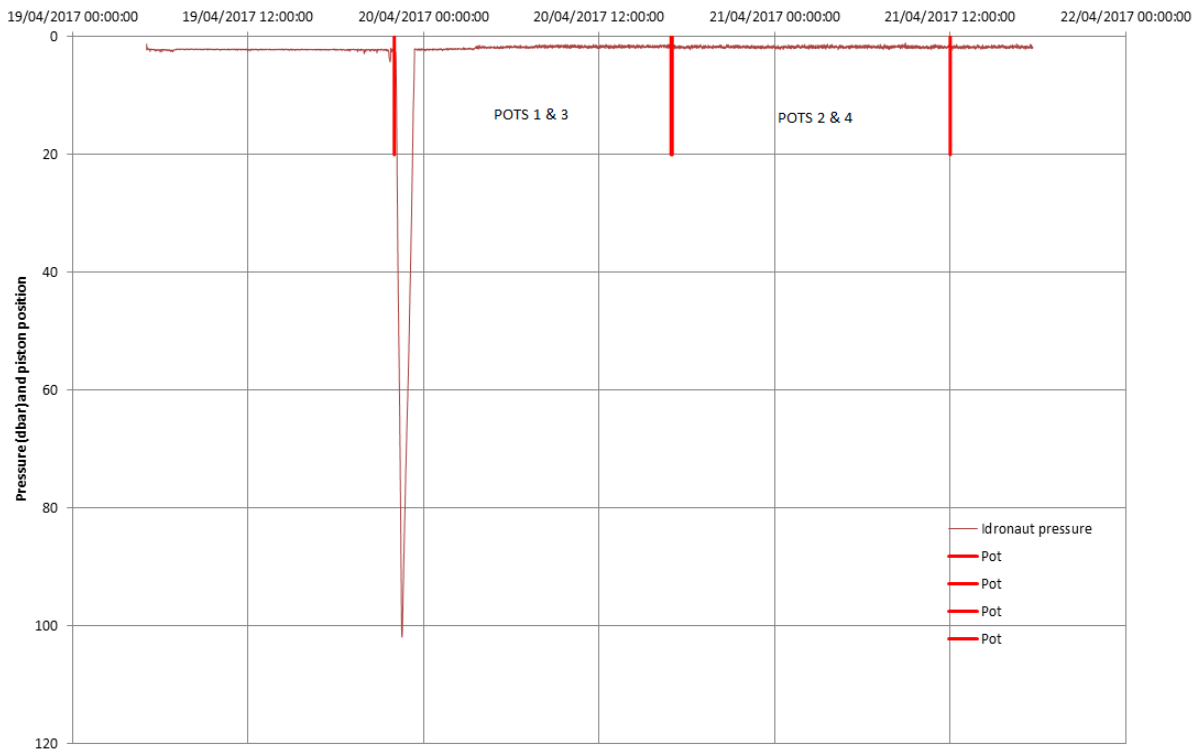
The depressor weight was released at 100 m as expected.

On recovery, the carousel was positioned as expected and the burn wire released at the expected time.

P8 (standard trap)

Station: DY077-025
 Target depth: 200 m
 Target temp: 11.313°C
 In situ density: 1027.995 kg m⁻³
 Added ballast: 3679 g
 Deployment time: 19.04.17 05:00
 Deployment posn: 49° 59.04' N
 16° 21.48' W

**P8 Deployment 1 - 19.04.17 - 200m
Station DY077-025**



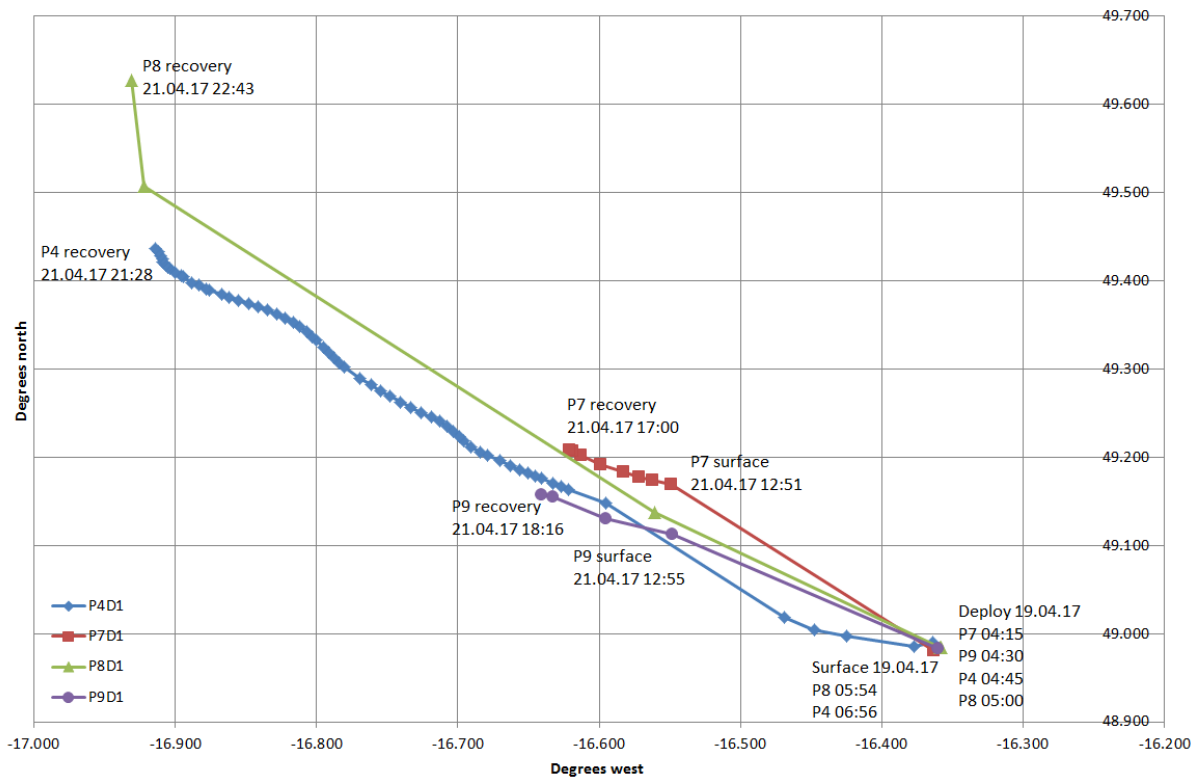
P8 appeared to be under-ballasted but did not sink at all until the first two sample pots opened. It then sank and returned to the surface after the depressor weight had released at 100 m. The APEX aborted and entered recovery mode. Nothing quantitative can be learned from this deployment regarding the ballasting error.

The depressor weight was released at 100m as expected.

On recovery, the carousel was positioned as expected and the burn wire released at the expected time.

It was noted that the sample cups were not completely full of brine when they were fitted to the trap prior to deployment. This left an appreciable air volume in the cups. This was not initially regarded as a problem as the sample cup seals are made from open-cell foam and water should have been free to pass through them to top up the cups. However, from the above plot it is clear that the trapped air must have been retained and released when the first pair of cups opened releasing enough buoyancy for the trap to sink. It is not clear why water was unable to pass the foam rings but it may have been that pores in the foam were clogged from previous deployments. **Old foam rings are to be replaced and sample cups must be filled to the brim before fitting to traps.**

Deployment 1 drift plot:

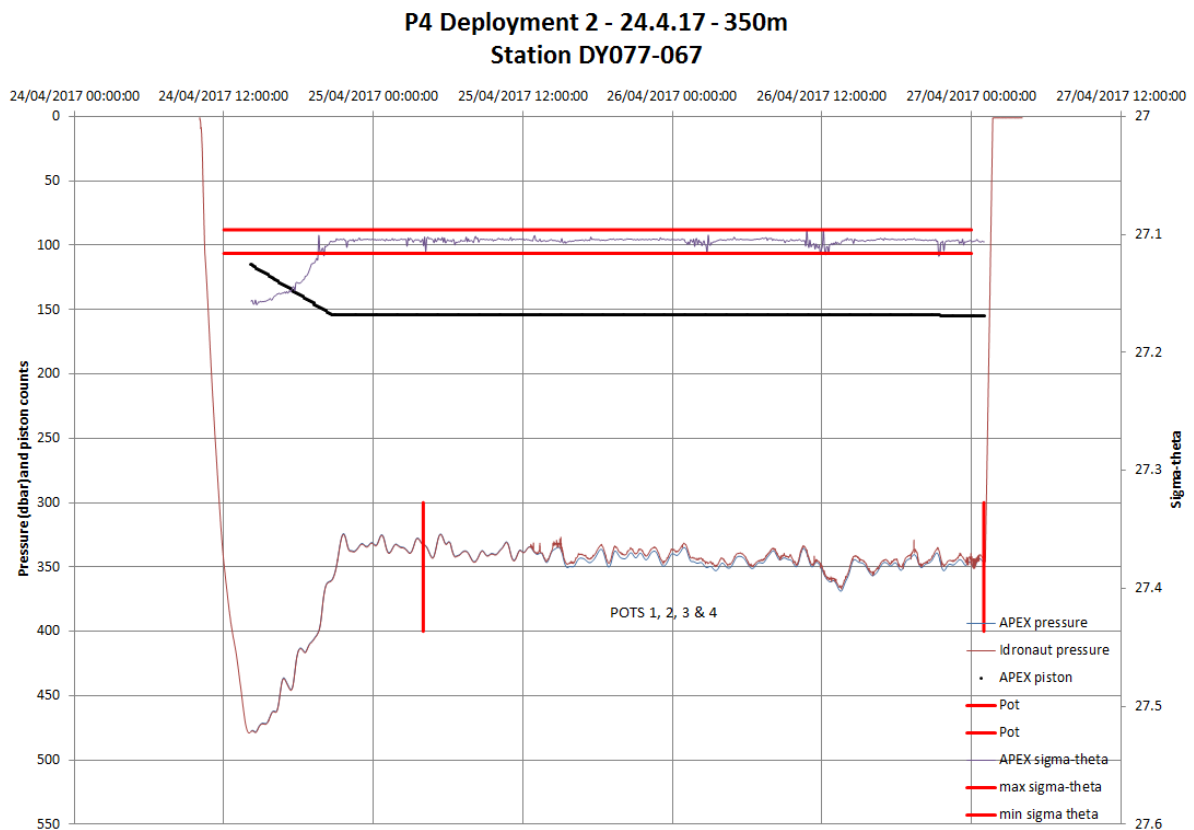


21.3 Deployment 2

For deployment 2, it was decided to deploy all four traps to 350 m. Due to the findings from deployment 1, a +30 g ballast adjustment was made to P4 and P8, a -20 g adjustment to P7 and a -60 g adjustment to P9. Also, due to poor telemetry from P7, P8 and P9 during deployment 1 that was put down to the APEX Iridium antennae being washed over, an amount of fixed ballast was removed from all traps and transferred to the end-of-mission abort weight to increase buoyancy at the surface.

P4 (camera trap)

Station: DY077-067
Target depth: 350 m
Target temp: 11.151C
In situ density: 1028.682 kg m⁻³
Ballast transferred: 115 g
Ballast adjustment: +30 g
Added ballast: 3208 +115 + 30 = 3353 g
Deployment time: 24.04.17 10:00
Deployment posn: 48° 57.54' N
16° 19.44' W



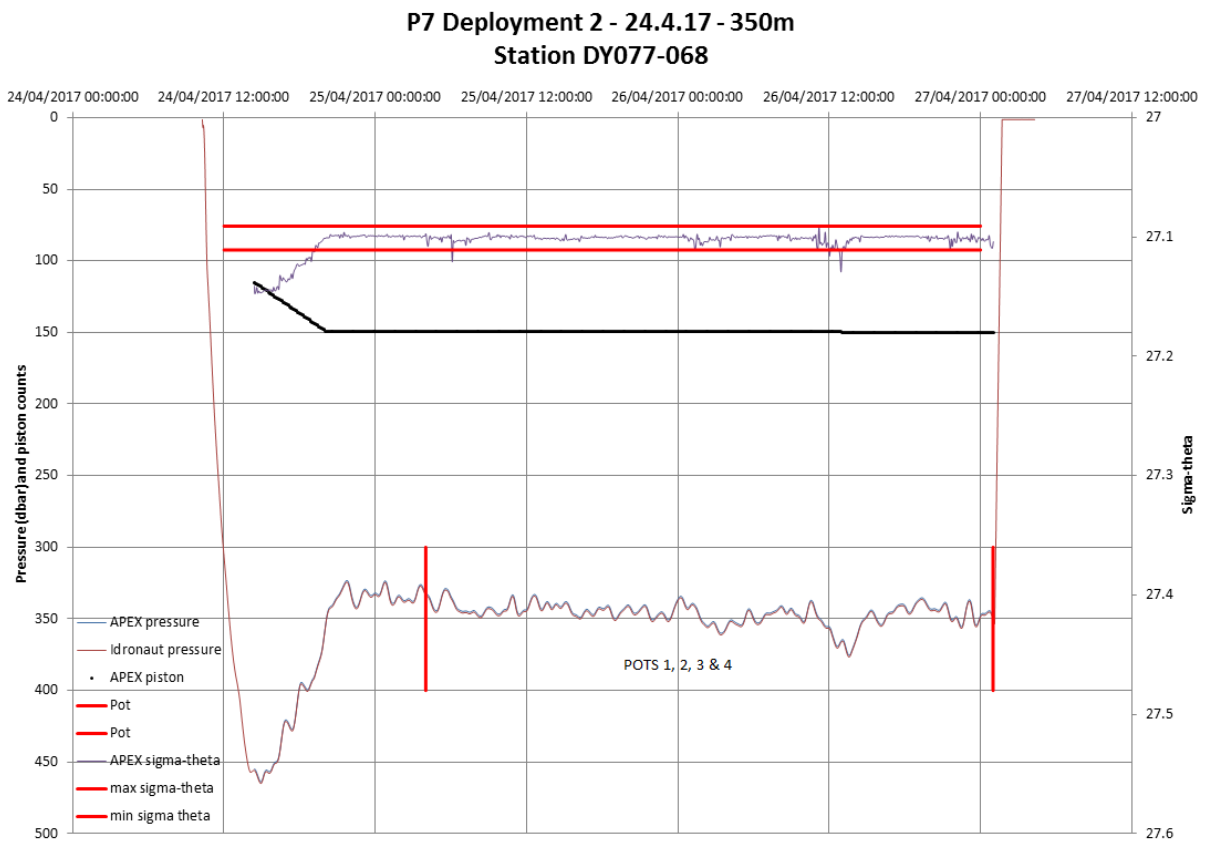
Here, P4 is a little over-ballasted and descends to 480 m indicating that the +30 g adjustment was too much. Stability was achieved with 39 counts adjustment of the APEX buoyancy engine. This suggests that P4 wasn't under-ballasted for deployment 1 but may have suffered from excess air in the cups as P8 did. The trap was fully stable well before the first sample collection period.

The depressor weight was released at 100 m as expected.

On recovery, all four sample pots had collected particles, the carousel was positioned as expected and the burn wire released at the expected time.

P7 (camera trap)

Station: DY077-068
Target depth: 350 m
Target temp: 11.151°C
In situ density: 1028.682 kg m⁻³
Ballast transferred: 170 g
Ballast adjustment: -20 g
Added ballast: 3303 + 170 – 20 = 3453 g
Deployment time: 24.04.17 10:15
Deployment posn: 48° 57.60' N
16° 19.38' W



P7 is still a little over-ballasted and descended to 460 m despite removing 20 g. Stability was achieved with 34 counts adjustment of the APEX buoyancy engine indicating a 50 g reduction may have been more applicable. The trap was fully stable well before the first sample collection period.

The depressor weight was released at 100 m as expected.

On recovery, all four sample pots had collected particles, the carousel was positioned as expected and the burn wire released at the expected time.

P8 (standard trap)

Station: DY077-069
Target depth: 350 m
Target temp: 11.151°C
In situ density: 1028.682 kg m⁻³
Ballast transferred: 705 g
Ballast adjustment: +30 g
Added ballast: 3679 + 705 + 30 = 4414 g
Deployment time: 24.04.17 10:30
Deployment posn: 48° 57.48' N
16° 19.68' W

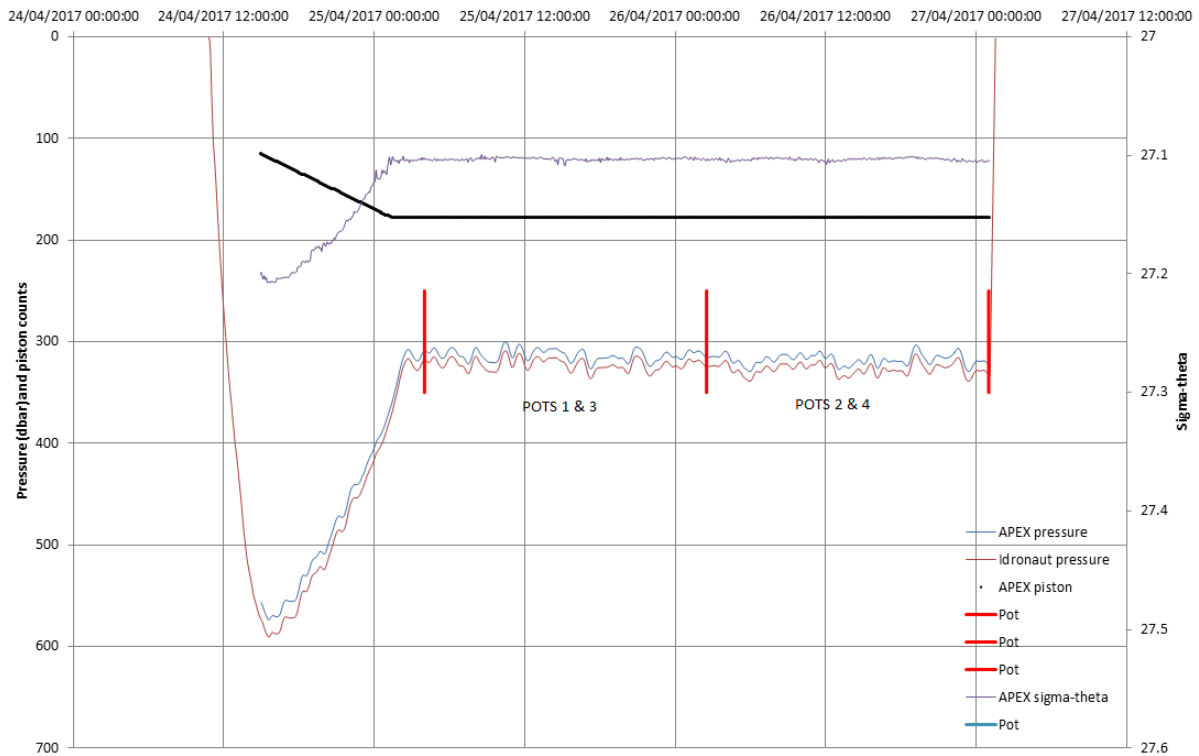
P8 failed to communicate at all since its predicted surface time. A search was carried out in the vicinity of the expected position assuming it had surfaced at the programmed time. The reasons for the trap failing to communicate are unknown but could include:

- Trap descended too deep and the emergency abort weight failed to release at 1000 m. (*All releases have been refurbished and fully tested at NOC.*)
- Trap is on the surface but the APEX telemetry has failed. (*P8 did successfully telemeter its position whilst on deck during mission prelude and it worked for deployment 1 albeit intermittently – this was put down to over-washing of the Iridium antenna.*)
- Trap is on the surface and APEX telemetry is working but messages are not being received on the Iridium server at TWR or NOC. (*There is certainly an issue with the server at NOC as previously described but the TWR server has appeared to be totally reliable with P8 making successful transmissions up until this point.*)
- The timer and/or burnwire have failed in some way so the end-of-mission weight hasn't released. This may cause the trap to be neutrally buoyant at some depth below the surface and so telemetry is impossible. (*This is a possibility and is in fact what happened last year on DY050. If this is the case, the burnwire may eventually corrode through and the trap may yet surface and communicate – this may take several weeks or months.*)
- Something may have flooded; APEX float, Idronaut logger, buoyancy hoop. (*This is always a possibility.*)

P9 (standard trap)

Station: DY077-070
Target depth: 350 m
Target temp: 11.151°C
In situ density: 1028.682 kg m⁻³
Ballast transferred: 1004 g
Ballast adjustment: -60 g
Added ballast: 3462 + 1004 - 60 = 4406 g
Deployment time: 24.04.17 10:45
Deployment posn: 48° 57.48' N
16° 19.86' W

**P9 Deployment 2 - 24.04.17 - 350m
Station DY077-070**

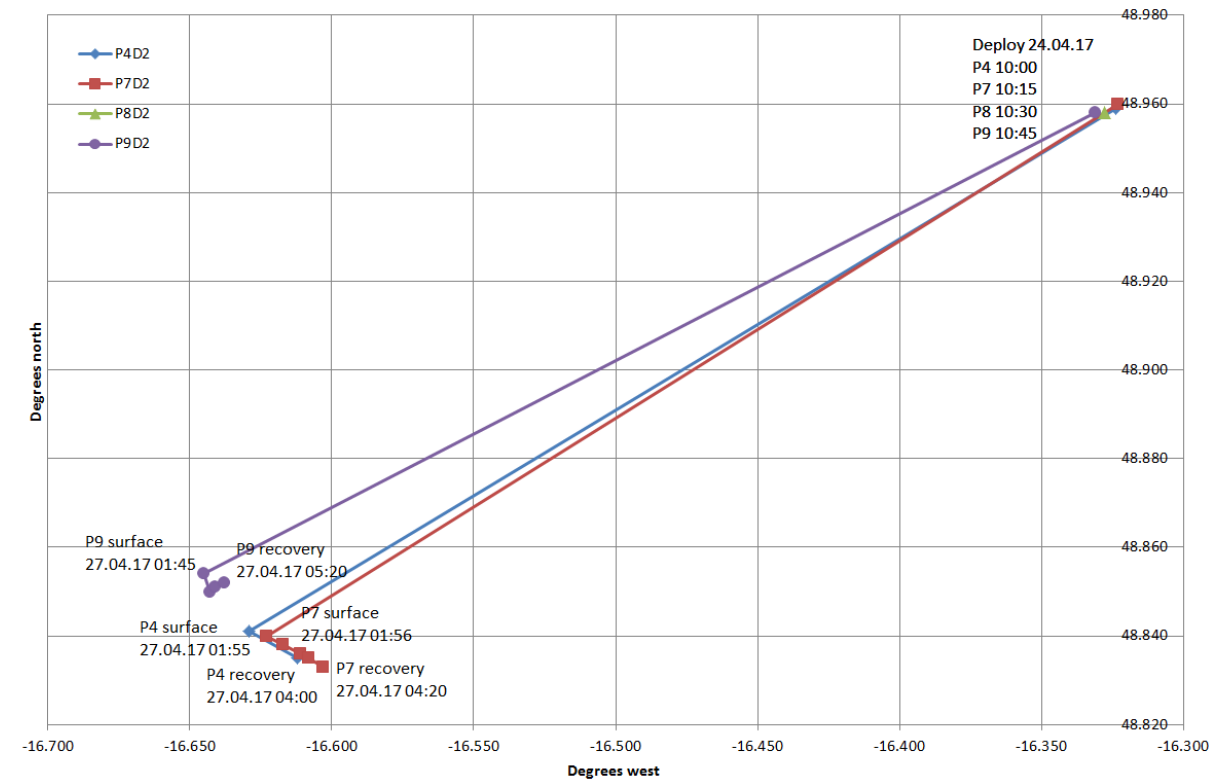


P9 is still a little over-ballasted and descended to 590 m despite removing 60 g. Stability was achieved with 63 counts adjustment of the APEX buoyancy engine indicating a 100 g or more reduction may have been more applicable. The trap was fully stable just before the first sample collection period.

The depressor weight was released at 100 m as expected.

On recovery, all four sample pots had collected particles, the carousel was positioned as expected and the burn wire released at the expected time.

Deployment 2 drift plot:



22 Upper Ocean Sediment Trap and Carbon Flux Measurement Method Intercomparison

Buesseler, Estapa, Pike, Kenyon

The main objective of the measurements described below was to intercompare a suite of modern methods for detecting sinking carbon flux out of the surface ocean. Collection methods included two designs of neutrally-buoyant sediment traps (PELAGRA of NOC design, and NBSTs of WHOI design), a surface-tethered drifting trap array (STT) carrying two trap tube designs and testing the effects of trap lid closure, water column ^{234}Th deficits, and flux measurements derived from water column camera profiles and microscopic imagery of gel collectors deployed in the sediment traps.

The intercomparison matrix below, taken from the US NSF Chemical Oceanography proposal that funded the WHOI and Skidmore participants, has been updated to include the number of successful method intercomparison points generated during the DY077 cruise. To the originally proposed list we have also added tests of different trap tube designs (on the STT array; $N = 4$); a test of the effects of trap lid closure ($N = 1$); and an intercomparison of gel trap media (cryogel and polyacrylamide gel; N

= 3). Carbon flux and image analyses will be further intercompared among the participating labs during the months to come.

	PEL-FLUX	STT-FLUX	NBST-GEL	PEL-GEL	STT-GEL	NBST-OST	PEL-CAM	234Th
NBST-FLUX	N = 1	N = 2	N = 2			N = 2		N = 2
PEL-FLUX		N = 4*		N = 3			N = 3	N = 4
STT-FLUX								N = 3*
NBST-GEL				N = 2	N = 2	N = 2		
PEL-GEL					N = 3*		N = 3	
STT-GEL								
NBST-OST								
PEL-CAM								

■ Inter-platform comparison
■ 3D 234Th-trap comparison
■ Sinking particle detection comparison

Replicate platforms and high-resolution 234Th/OST will be used to assess and control for small-scale variability

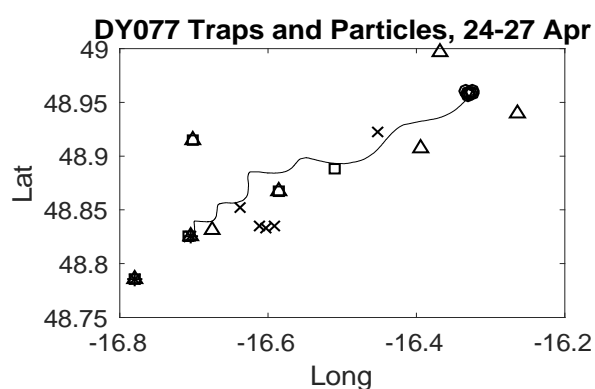
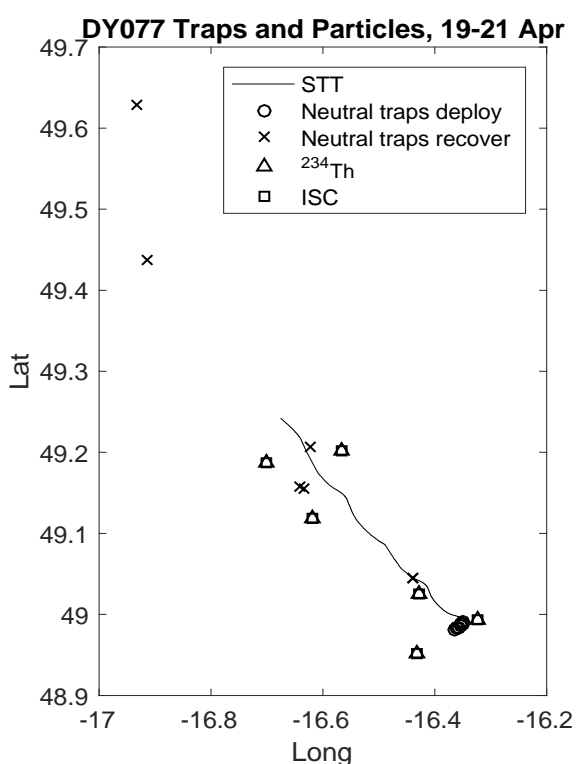
NBST = neutrally-buoyant sediment trap PEL = PELAGRA trap
 GEL = polyacrylamide gel collector imaging CAM = camera
 OST = optical sediment trap STT = surface tethered trap
 FLUX = bulk geochemical flux

* Includes comparisons to Depl. 1 STT at 350 m where trap lids did not close

Below we describe the equipment and deployment details for the WHOI designed NBSTs, sample processing details carried out by the WHOI-Skidmore team for the NBST and PELAGRA traps, Thorium-234, and large volume pumps used to support the Thorium -234 measurements. Two figures on the next page show the deployment, recovery, and drift locations (where known) of the different sediment traps, camera profiles, and Thorium-234 profiles.

22.1 WHOI Neutrally Buoyant Sediment Traps (NBSTs)

NBSTs consist of four cylindrical sediment trap tubes (collection area = 0.0113 m²) and a 0.25 m pathlength transmissometer (C-Rover 2000, WETLabs, Philomath, OR) arranged around a central, SOLO profiling float. The traps are programmed to sink to a predetermined depth, drift while collecting sedimenting particles, close the trap lids, and then rise to the surface at a programmed time for recovery. Recovery aids consist of GPS/Iridium and a flashing strobe light. The transmissometer operates as an “optical sediment trap” and measures attenuation flux as a function of time, which is a proxy for sinking particulate carbon flux. For the deployments conducted on DY077, trap tubes were set up as follows: Three tubes were prepared with a layer of 500 mL of 70 ppt brine poisoned with



Figures above show the locations of platforms during deployment 1 (19-21 Apr) and deployment 2 (24-27 Apr). See elsewhere in the cruise report for a description of the ISC and PELAGRA traps.

0.1% formaldehyde and borate buffered to pH 8.5. This brine layer was overlain with 1 μ m-filtered seawater from 350m. In the fourth trap tube, a jar containing approximately 50mL of polyacrylamide gel replaced the brine layer and allowed preservation of collected particles for microscopic imaging after recovery. During deployment 1, two NBSTs were programmed to sample at a depth of 200m (one bailed out early, one returned as programmed) and two at a depth of 350m (one bailed out early and one did not resurface). During deployment 2, three NBSTs were programmed for a depth of 350 (one bailed out early, one sampled as intended, and the third did not resurface).

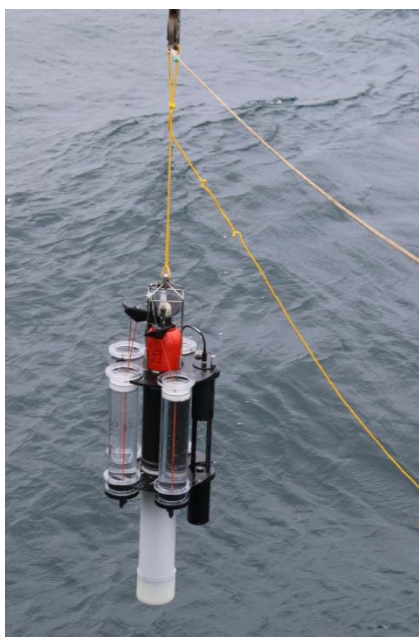
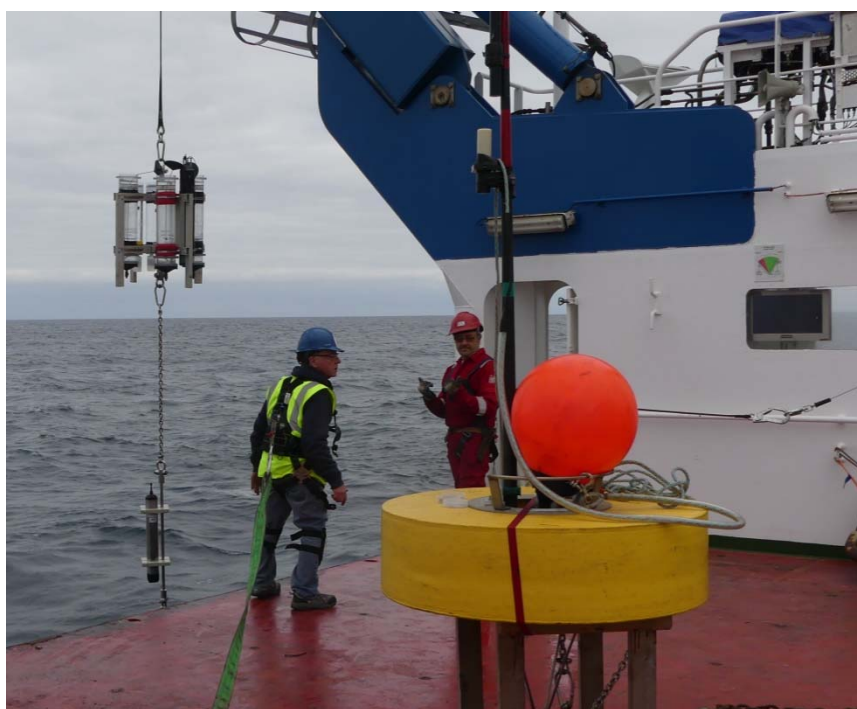


Photo of NBST being deployed (left) and SST trap and float (right



22.2 WHOI Surface Tethered Trap (STT) arrays

Alongside the NBSTs was deployed a drifting mooring carrying cylindrical sediment trap tubes set up identically to those on the NBSTs as well as tubes of a different design provided by collaborator C. Lamborg (and henceforth termed “Lamborg tubes”). During deployment 1 two arrays were deployed, one at 200 m and one at 350 m. Both arrays contained two “NBST” style brine-filled tubes, one NBST style gel tube, and two Lamborg tubes which collected samples into 125 mL bottles filled with the same poisoned brine used in the other tubes. A programmable burnwire controller was set up to close the NBST-style tube lids at the same time as on the NBST traps. The burnwire controller at 200 m operated as planned but the controller at 350 m did not. Upon post-deployment testing it was found that the 350 m burnwire controller’s program ran correctly, but the burnwire itself malfunctioned by sending out a constant, low voltage (0.3-0.4 V) rather than 9-12V only during the burnwire activation. The burnwire came up partially corroded but not fully disintegrated. During the second deployment, a single trap array at 350 m was deployed using the fully-functioning burnwire controller. Two NBST-style tubes were set up to close at the same time as the NBSTs, two more were set up to remain open, and a third pair of Lamborg style tubes (without lids) were included.

During both deployments a Nortek ([model number]) current meter was deployed looking downwards approximately 2 m below the bottom of the 350 m trap array. Preliminary observations indicate that during deployment 1, the horizontal and vertical velocities were always less than 10 cm/s, with a median horizontal velocity of 6 cm/s. During deployment 2 the velocities increased during the

deployment to reach a maximum of 23 cm/s (horizontal) and 20 cm/s (vertical), with a median horizontal velocity of 13 cm/s.

22.2.1 **Trap sample processing**

Upon retrieval, trap “brine” samples were processed as follows.

NBSTs and NBST-style tubes on STT: After a period of 1-3 hours to allow particles to finish settling in trap tubes, overlying filtered seawater was removed via peristaltic pump. The bottom brine layer was screened through 350 μm nylon mesh to aid in swimmer removal. The three replicate brine tubes were drained through a single screen and combined. The screen was picked under 12x magnification to remove obvious swimmers while leaving behind passively sinking particles. Material remaining on the screen was rinsed back into the main sample while swimmers were filtered onto a QMA filter for later carbon and Thorium-234 analysis. Combined trap samples were split eight ways using a custom rotary splitter. Splits were filtered as appropriate for C/N, ^{234}Th counting, PIC, biogenic Si, and mass flux determination on shore. Splits were also kept aside to return to collaborators labs at NOC.

Lamborg-style tubes on STT. Overlying seawater was siphoned off as above, then 125 ml sample collection bottles were removed and combined into an extra NBST tube used as a “dispenser”. The sample was processed from this point identically to the NBST tubes.

PELAGRA trap samples: Brine cups were removed and either kept by the NOC lab for parallel processing (generally cups 3 and 4) or treated as described for Lamborg tubes above, minus the siphoning step.

Trap “gel” samples were processed by siphoning off (as above) filtered seawater from NBST gel collector tubes (this step was not necessary for PELAGRA gels). The gel collectors were then capped and allowed to stand for 24 hours. A 10 mL pipet was used to suction off remaining overlying seawater down to the gel interface, and gels were then imaged using transmitted light at low magnification with a custom imaging setup belonging to M. Iverson (Basler acA4600 7gc camera, Edmund Optics 16 mm/F1.8 86571 lens)

22.2.2 **Thorium-234**

Thorium-234 profiles were located around the projected drift track of the traps at intervals through both deployments (see figures above). Sets of three profiles spaced 10 km apart were arranged in a triangle centered on the trap drift position.

Four liter samples were collected from the CTD/Rosette for the analyses of ^{234}Th at sea. The method entails collection of a 4L sample, adding a stable Th yield monitor and pH adjustments resulting in the formation of a Mn precipitate that scavenges Th which is then filtered on to a 25 mm diameter quartz filter. The filter is dried, mounted and beta counted at sea. Sampling was conducted as sets of 3

stations (or 2 for last set), forming roughly a triangle of equal 10 km sides positioned around the central drifting trap array. Samples were taken to coincide with the two trap deployments.

A total of 161 ^{234}Th samples were collected on the following CTD's & dates:

Deployment 1

CTD 4, 5, 6 all on April 19th

CTD 8, 9, 10 all on April 21

Deployment 2

CTD 15, 16, 17 all on April 24

CTD 19, 20, 21 all on April 26

Post deployment 2

CTD 22, 23 all on April 28

Samples were all beta counted at least once on the RRS *Discovery* and will all be recounted after 5-6 months to determine the amount of “supported” beta activity that is not associated with ^{234}Th in the sample. Data will be adjusted for chemical yields and reported as of the date of sampling.



Jenn Kenyon (WHOI) sampling for thorium-234 from CTD rosette

22.2.3 In situ pumps

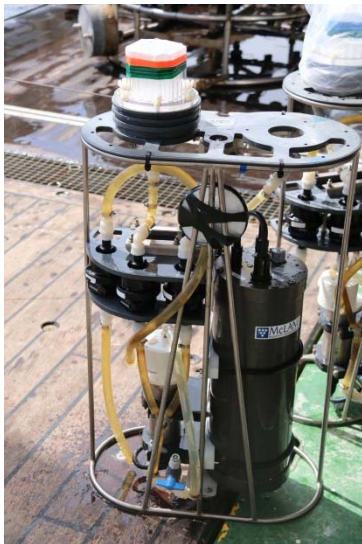
Two McLane in-situ battery powered pumps were deployed two times for the collection of size fractionated particles. The water passes first through a 51 micron screen followed by a nominal 1 micron quartz filter. Filter diameters are both 142mm and a baffled opening developed for the GEOTRACES program keeps particles from washing off the top screen during retrieval of the pumps as they ascend on the wire. The pumps were programmed with a 1 hour delay time before turning on at depth after being attached to the wire to reach depths of 200 and 350m. After a pumping time of 2 hours, the pumps shut off and were retrieved. After retrieval, volumes are noted (measured by dual flow meters), any water remained was drained through the filters, and in the lab, the screen is rinsed with prefiltered seawater on to a 1 um pore sized silver filter (25mm diameter). The Ag filter and a 25mm subsample from the QMA are dried, mounted and beta counted for ^{234}Th . The filters will be recounted 5-6 months later for supported ^{234}Th and then dismantled. Weighed slices will be used for CHN, PIC and biogenic Si analyses (on Ag only).

Deployments on RRS *Discovery* included-

April 19, station # 38, 200 & 350m, volume pumped = 894 L at 350m and 787 L at 200m

April 26, station # 88, 200 & 350m, volume pumped = 885 L at 350m and 871 L at 200m

Photo of McLane pumps on RRS *Discovery* DY 077 cruise-



23 FixO³-TNA project LO³CAted

Luciana Génio

A new modular device, consisting of a colonization frame that hosts three experimental substrates (wood, bones and oyster shells) attached to a cross array of four passive larval tube traps (Fig. 1), has been developed under the FixO³-TNA project LO³CAted to study deep-sea larval distributions and settlement in the open ocean. During PAP cruise DY077 a series of activities were conducted, including (i) deployment of new sampling devices on PAP#3 and Bathysnap moorings, and (ii) collection of samples from LO³CAted settlement frames and larval traps deployed on PAP#3 mooring during 2016 PAP cruise. Details of these activities are described below



Figure 49. LO³CAted modular sampling device. From left to right: settlement frame [14 cm Ø; 55 cm height] enclosing containers [12.5 cm Ø; 13 cm height] with experimental biogenic substrates; larval traps consisting of three stacked 50 ml Falcon tubes, which are inserted inside a PVC tube and can be attached on top of the settlement frame in a cross arrangement. The complete device can be fixed to the mooring line with plastic clamps.



Figure 50. LO³CAted settlement frames and larval traps prepared for PAP#3 mooring deployment below NORTEK AQD 2960m (Left) and NORTEK AQD 4730m (Right).

23.1 PAP#3 mooring deployment

Two sets of LO³CAted frames were clamped to the PAP#3 mooring deployed as station DY077-040 on 20/4/2017. Each set includes two settlement frames with experimental substrates, with the upper frame (shallower) having four passive larval tube traps attached on top (Fig. 2). The frames were attached to a metal bar and inserted in line under NORTEK AQD 2960m and NORTEK AQD 4730m. The experimental substrates were enclosed in a 2mm mesh net inside PVC containers with holes for flowing water. Wood (12 pieces of 2 x 2.5 x 8.5 cm natural pine wood per basket) and oyster shells (~20 valves per basket) were previously prepared in the laboratory at Aveiro University (Portugal). Wood was subjected to a heat shock (56°C for 30 min), and shells were brushed and washed with tap water, and dried at 60°C. Cow bones were bought in Southampton and frozen at the National Oceanography Centre, then taken onboard and placed inside four net baskets (~550 – 650 g per basket). Experimental substrates (wood, bones and shells) were randomly ordered in each colonization frame. Final arrangement of substrates is shown in Table 1:

Table 11. Experimental substrates order in each LO³CAted settlement frame

Depth	Frame	Top	Middle	Bottom
2960 m	Upper	Shell	Wood	Bones
	Lower	Wood	Shell	Bones
4730 m	Upper	Bone	Shell	Wood
	Lower	Shell	Bone	Wood

Larval traps were filled with 20% Dimethyl sulfoxide saturated with NaCl (~40g per liter). The fixative solution was prepared onboard using Milli-Q water (stir for ~1h and let to settle overnight) and kept refrigerated until deployment. The funnel-shaped stack of Falcon tubes form internal baffles that prevent larval escape and wash out. Falcon tube columns were washed with Milli-Q water (3x) and dried overnight before being filled with fixative solution. The tube traps were covered with parafilm to prevent the fixative release during mooring descent (Fig. 3). The parafilm was secured with rubber bands attached to a magnesium fusible link that dissolves after a few days in seawater. When the link dissolves, a rubber band pulls off the plastic film, opening the trap.



Figure 51. Larval traps covered with parafilm secured with rubber bands and magnesium links.

23.2 PAP#3 mooring recovery

On 23/4/2017, LO³CAted sampling devices were recovered from PAP#3 mooring deployed as station DY050-025 during the 2016 PAP cruise (24/4/2016). The shallower set of devices was directly clamped to the frame of sediment trap 2997m (Fig. 4) and was removed from the frame as soon as it was safely secured on deck (Fig. 5).



Figure 52. LO³CAted settlement frames and larval traps clamped to Sediment trap 2997m of PAP#3 mooring.

Individual substrate containers were immediately transferred to 5L plastic buckets and placed in the cold room at ~5°C (Fig. 5). The following procedure was performed for each substrate: 1) net basket was removed from the PVC container; 2) line securing the top of the net basket was cut and top net cover was lifted; 3) substrate top view was photographed; 4) subsamples were preserved into different fixatives, according to the table below, for future processing in the laboratory. Ethanol-cleaned forceps were used to transfer substrate samples.



Figure 53. LO³CAted settlement frames being removed from sediment trap frame (left) and substrate containers transferred

Table 12. Distribution of substrate samples among different fixatives.

Substrate	-80°C	4% Formalin	95% Ethanol ¹
Wood	2 laths	2 laths	Remaining laths
Bone	2-3 pieces	2 pieces	Remaining pieces
Shells	4 valves	4 valves	Remaining valves

¹including mesh net

Larval tube traps were also removed from the sediment trap frame and taken to the wet lab. Individual DMSO-preserved larval trap samples were transferred to 120 mL labeled sample vials (Table 3). Three tubes were opened, but parafilm cover was still present in one of the recovered tubes (sample 3), which was placed on the side of the wire attachment on top of the sediment trap. Neither rubber bands, nor magnesium link were present.



Figure 54. LO³CAted settlement frames and larval traps being recovered from PAP#3 mooring line 45m below sediment trap 4732m.

Table 13. Summary of samples collected from LO³CAted larval traps after one-year deployment on PAP#3 mooring (DY050-025, 24/04/2016) during DY077. DMSO – Dimethyl sulfoxide 20%

Depth	Larval Trap	Preservation
2997 m (Sediment trap frame)	1	DMSO
	2	DMSO
	3 *	DMSO
	4	DMSO

*sample kept for use as negative

The second (deeper) set of settlement traps, which was attached 45m below the sediment trap 4732m, was recovered from the mooring line about one hour later and taken to the wet lab. The cross of four larval tube traps, which was deployed attached to the top of the upper settlement frame, was not retrieved. Only the screw used to attach the traps to the substrate frame was present. Substrates containers were transferred to the cold room in separate new 5L buckets and the above-described procedure was followed for sample processing. All substrates showed no visible signs of degradation and macrofauna colonization. Bone surfaces were cleaned although loose remains of fat were still present. No obvious difference was observed between substrates deployed at 2997m and 4777m depth



(Fig. 7). A summary of samples collected is shown in Table 4.



Figure 55. Experimental substrates (from left to right: shells, bones, wood) recovered from LO³CAted settlement frames deployed at 2997 m (top) and 4777 m (bottom) in PAP#3 mooring.

Table 14. Summary of samples collected from LO³CAted settlement frames after one-year deployment on PAP#3 mooring (DY050-025, 24/04/2016) during DY077. EtOH – Ethanol 95%, bF – Buffered Formalin 4%

Depth	Settlement frame	Substrate order	Substrate	Preservation
2997m (Sediment trap frame)	A	Top	Shell	EtOH, bF, -80°C
		Middle	Wood	EtOH, bF, -80°C
		Bottom	Bone	EtOH, bF, -80°C
2997m (Sediment trap frame)	B	Top	Bone	EtOH, bF, -80°C
		Middle	Wood	EtOH, bF, -80°C
		Bottom	Shell	EtOH, bF, -80°C
4777 m (Mooring line)	Upper	Top	Bone	EtOH, bF, -80°C
		Middle	Shell	EtOH, bF, -80°C
		Bottom	Wood	EtOH, bF, -80°C
4777 m (Mooring line)	Lower	Top	Bone	EtOH, bF, -80°C
		Middle	Shell	EtOH, bF, -80°C
		Bottom	Wood	EtOH, bF, -80°C

23.3 Bathysnap

One substrate platform, retrieved from the PAP#3 mooring (DY050-025, 24/04/2017) was prepared with wood substrates and clamped upright to the rear side of the Bathysnap frame. Untreated pine wood laths available on-board were cut into pieces (10 x 4 x 2 cm) and placed inside mesh net baskets (7 pieces per basket). Because spare plastic net material (standard 2mm mesh net used in LO³CAted experiments) was only available for one basket, two other baskets were improvised using non-slip neoprene mat of approximately 2mm mesh size of irregular shape (Fig. 8). The individual larval tube traps were also recovered from PAP#3 mooring (DY050-025, 24/04/2017), prepared as described in above section 1, and attached to the centre of the Bathysnap frame. Bathysnap was deployed on 25/04/2017 as station DY077-084 (Fig. 9).



Figure 56. Wood substrate baskets prepared for Bathysnap deployment.



Figure 57. Bathysnap with one LO³CAted settlement frame attached upright on the rear of flash side and four larval traps attached on the top centre of the frame around release.

23.4 Future work

In the laboratory, substrate ethanol-preserved samples will be screened under a stereomicroscope for macrofauna specimens. Frozen and formalin-fixed substrates will be used for microbial community studies using molecular tools and Scanning Electron Microscopy. Larval trap samples will also be sorted under a stereomicroscope and identified using molecular markers.

The results obtained from PAP Sustained Observatory will be compared with data collected from three other FixO³ sites (ESTOC, CVOO and PYLOS), and the Nazaré Canyon mooring (MONICAN01). LO³CAted results will provide new insights into spatial and temporal patterns of larval assemblages across geographic and depth gradients, advancing the existing knowledge of biogeographic distributions and connectivity of deep-sea metapopulations.

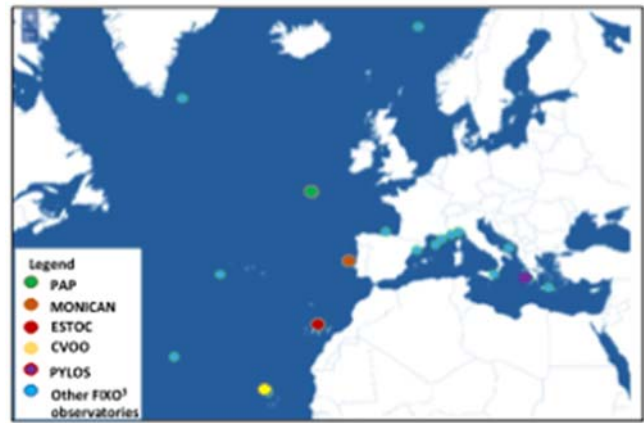


Figure 58. Study sites and other FixO³ observatories in North Atlantic and Mediterranean Sea

24 Benthic Studies

Brian Bett, Andrew Gates, Rob Young, Claire Laguionie-Marchais, Lenka Nealova, Noëlie Benoist, and Luciana Genio

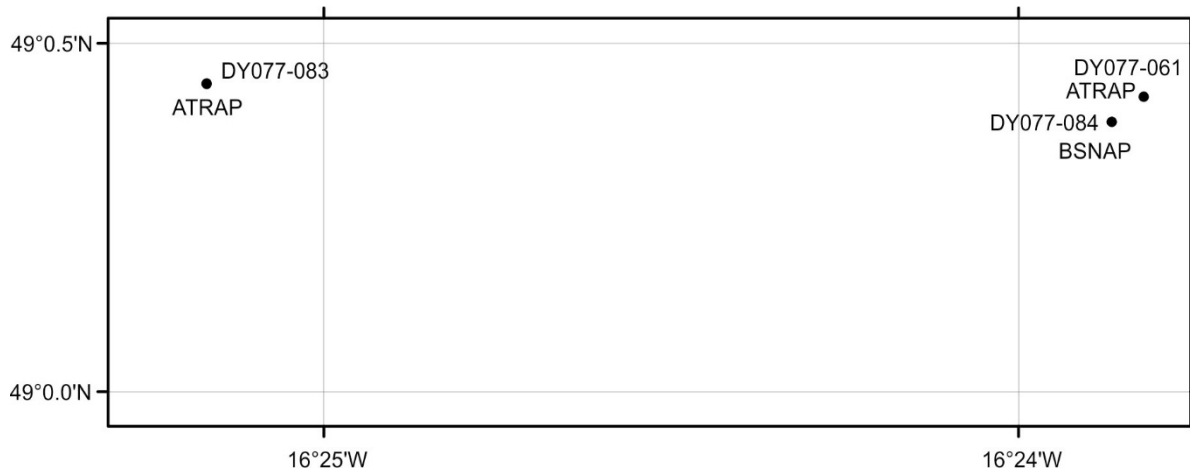
The benthic group aboard RRS *Discovery* IV cruise 077, aimed to continue time-series observations of the benthos and seafloor of the Porcupine Abyssal Plain Sustained Observatory site, originally initiated in 1985. Objectives for the 2017 cruise included: (i) a replicated set of seabed samples collected by Megacorer to serve a variety of purposes, (ii) duplicate otter trawl samples of the megabenthos; (iii) duplicate amphipod trap sample sets; and (iv) the deployment of a long-term (1-year) Bathysnap time-lapse seafloor camera system. These objectives were largely met during the course of the cruise, as described below. Benthic Station List preview:

Station Number	Gear code	Date 2017	Time	Latitude UTC	Longitude	Dep. (m)	Sou. (m)	Comment
DY077-016	MgC08+2	17/04	19:01	48 50.246	016 31.199	4845	4845	7/10 good cores
DY077-020	MgC08+2	18/04	20:00	48 50.431	016 31.095	4845	4845	8/10 good cores
DY077-021	MgC08+2	19/04	00:06	48 50.038	016 31.542	4844	4844	7/10 good cores
DY077-056	MgC08+2	22/04	09:36	48 50.309	016 31.449	4844	4844	4/10 good cores
DY077-057	MgC08+2	22/04	13:47	48 50.225	016 31.686	4844	4844	2/10 good cores

DY077-059	OTSB14a	23/04	01:00	48 55.100	016 41.100 4843 4844	Large mass
		23/04	05:30	48 52.900	016 29.600 4846	Distance
						run c. 14.5 km
DY077-061	ATRAP	23/04	20:07	49 00.423	016 23.820 4846 4846	Good
		25/04	09:07	49 00.423	016 23.820 4846	Soak time =
						37 hours
DY077-064	MgC08+2	24/04	01:26	48 50.251	016 31.472 4844 4844	10/10 good
						cores (1 lost later)
DY077-065	MgC08+2	24/04	05:23	48 50.363	016 31.288 4844 4844	9/10 good
						cores
DY077-082	MgC08+2	25/04	03:40	48 50.048	016 31.379 4845 4845	6/10 good
						cores
DY077-083	ATRAP	25/04	14:21	49 00.442	016 25.168 4846 4846	Good
		28/04	13:48	49 00.442	016 25.168 4846	Soak time =
						71.5 hours
DY077-084	BSNAP	25/04	16:03	49 00.387	016 23.866 4846 4846	8-hr
						intervals
						For recovery 2018; with colonisation substrata; s/n 686 ARM 160D REL 1655
DY077-086	MgC08+2	25/04	22:34	48 50.308	016 31.224 4843 4843	1/10 good
						cores
DY077-087	MgC08+2	26/04	01:53	48 50.340	016 31.078 4843 4843	10/10 good
						cores, no USBL data
DY077-102	OTSB14a	27/04	15:28	48 50.727	016 40.515 4840 4844	Good catch
		27/04	17:50	48 55.227	016 32.659 4847	Distance
						run c. 12.6 km

24.1 Moorings

Two small bottom moored systems were employed during the course of the cruise: “Bathysnap” (BSNAP), a time-lapse seafloor photography system intended for long-term deployment (c. 1-year), and an “Amphipod trap” (ATRAP), carrying four simple baited traps for short-term deployments (1-2 day).



Chartlet showing benthic group mooring stations.

24.2 Bathysnap

An upgraded Bathysnap system was employed this year. The frame was constructed just prior to the cruise, and incorporated minor modifications in the method of construction (structural members were plate and bolt joined rather than glued), ballast weight shape and corresponding retainer were modified in shape. Flashgun alignment was adjusted at sea, drawings should be amended prior to construction of the second unit.

A new camera system was employed: Kongsberg OE14-408-0016 digital stills camera, and OE11-442-0016 flashgun, powered and controlled by an Oceanlab Oceanback III unit. The manuals supplied with these components are very limited, consequently, full set-up details are included here.

24.2.1 Set-up steps

1. Primary camera settings (shutter speed, aperture, etc.)
2. Administrative camera settings (date/time, etc.)
3. Camera operational settings (flash on, intervalometer on)
4. OCEANBACK timer settings
5. Connect camera, flash, OCEANBACK, and start the system – ready to deploy

24.2.2 Camera set-up

Inside the Kongsberg OE12-408 is a Canon PowerShot G11 camera, accessing the camera user manual makes the set-up procedure a lot more obvious. The Kongsberg GUI for the camera attempts to replicate the controls found on the back of the consumer camera, these are mostly self-explanatory

(when you have the Canon manual), perhaps most confusing is the operation of the “control dial”, on the consumer camera this is a knurled wheel the user rotates manually, on the GUI, the “control dial” is represented by a light green shaded circular feature having a “o” at the top centre, to operate the dial, mouse click left or right of the “o” to decrease or increase a camera setting etc. To monitor the camera set-up stages, it is necessary to have the camera connected (via its control box to a TV monitor). To operate the Kongsberg GUI, it may be necessary to use a serial-to-USB convertor.

1. Primary Camera settings (assumes camera is powered on and GUI is running)

Select a range of camera settings as appropriate to the intended subject etc.:

- Ensure that the camera’s memory card is empty. Fit the supplied USB download cable from camera to laptop. Select “settings” tab, click “Image Download” button (camera view on TV monitor should shut down). Open laptop file manager, navigate to camera storage media, delete any images and image folders. Click “Image Download” button (normal camera view should return on TV monitor).
- GUI upper panel, set “ZOOM” to fully wide
- GUI upper panel, set “MODE” to C2Mode (intervalometer)
- GUI upper panel, set “ISO” to 100
- GUI upper panel, set “EXP COMP” to 0
- Press “light metering button” (eye symbol, mid right of GUI), then use “control dial” to set shutter speed to 1/250
- Press “light metering button”, then use “control dial” to set aperture to F5.0
- Press manual focus (MF) button (= up arrow), then use “control dial” to set focus distance to about 2-3 m (this will not be critical so near 2 or a little above).
- Press Function/Set button (FUNC.) (blue circle between arrows), opening menu, scroll down with arrow key to image format option, and scroll right with arrow key to select “RAW”, press FUNC. to select and exit menu.
- Press FUNC., opening menu, scroll down to flashpower setting, scroll right/left to achieve “1/4” power option, press FUNC. to select and exit menu.

2. Administrative Camera settings (must be saved as end step!)

- Press menu button (MEN), press right arrow to enter tools (spanner and hammer symbol)
- Scroll down to file numbering and set to “Continuous”
- Scroll down to Create Folder and set “Monthly”

- Scroll down to Date/Time, and set current date and UTC time using arrow button, press FUNC. (= OK) to accept settings
- Scroll down to “RAW + FL” (F is a quadrant symbol representing ‘fine’), set to “OFF”
- Scroll down to Save Setting and select “C2”, press FUNC. to accept “C2” setting. (THIS IS CRITICAL)

3. Camera operational settings

- Power off the camera (i.e. switch off bench power supply)
- Power on the camera (i.e. switch on the bench power supply)
- [repeat manual focussing – not clear camera holds this setting?]
- Select “Settings” tab on the GUI, and select “Setup...” under the “Intervalometer” heading, untick ‘Use startup delay’, set all other value boxes to zero except ‘interval’ set to 10 seconds, click OK
- CRITICAL CHECK – check that the red flash symbol is displayed on the TV monitor
- If the Red flash symbol is not on, try the flash button in the upper part of the Settings panel of the GUI (be patient) – best option is likely to start “**3. Camera operational settings**” procedure again.
- If Red flash symbol is on – continue procedure.
- Aim the Kongsberg camera remote control handset at the camera window and press button “A”. You should now see (on the TV monitor) the camera switch to the saved “C2” mode and then begin firing at 10-second intervals. After 2 or 3 shots fire, power off the camera (i.e. switch off bench power supply) and it is ready for connection to the OCEANBACK.
- If the camera does not change to “C2” mode and begin firing – best option is likely to start “**3. Camera operational settings**” procedure again.

4. OCEANBACK timer settings

- Set-up requires use of a terminal emulator – I have used freeware PuTTY, which appears to work well with the OCEANBACK
- Set-up (and save for convenience) terminal emulator settings (COM port number, 115200 baud rate, 8 data bits, 1 stop bit, parity as none, flow control as none)
- Connect OCEANBACK COMMS port to laptop via supplied cable (device manager to check assigned COM port if necessary)
- Open session in terminal emulator
- Connect the supplied blind start cable to the OCEANBACK start port
- After short delay, OCEANBACK should boot up to menu
- Type ‘s’ to select “Set Start Delay Time”

- Type '00:00' and press enter – watch screen to see OCEANBACK confirm 0 seconds entry – this appears on screen only briefly !
- Type 'p' to select “Set Repeat Period” (note printed manual suggests input format will be “HH:MM”, but appears to be “DD:HH:MM”)
- Type '00:08:00' and press enter – watch screen to see OCEANBACK confirm 28800 seconds entry – this appears on screen only briefly !
- Type 'r' to select “Repeat Loop Count”
- Type '2000' and press enter
- You can now let the menu count down happen, or press 'b' to “Begin Acquisition” immediately
- In either case, the terminal should now display
“Beginning acquisition phase
Taking initial photo
<date time stamp> TAKE_PHOTO
Starting timed sequence”
- The next <date time stamp> TAKE_PHOTO should happen 8-hours later
- DO NOT REMOVE THE START CABLE – the manual suggests this is possible, but bench tests suggest that the sequence will not or not reliably restart.

5. Prepare for deployment

- Mount camera, flash, and OCEANBACK on Bathysnap frame
- Connect camera to flash
- Connect camera to OCEANBACK

Bathysnap DY077-084 was deployed on 25 April 2017, with the camera set to record Cannon RAW format images every 8-hours. In addition, the frame carried a set of larval traps and colonisation substrata as detailed elsewhere in this report (Luciana Genio). The mooring was of conventional form: lazy float – 15 m polyprop – Billings dan buoy [deepsea xenon strobe; NMFSS VHF beacon s/n A12-091] – 15 m polyprop – 4-ball main buoyancy pack – 50 m braid – IXSEA MORS B2S type release (NMFSS s/n 686, ARM 160D, REL 1655). Deployed position:

49° 00.387' N 016° 23.866' W



Bathysnap DY077-084 as deployed, note 4 larval traps top centre of frame around release position, and tube of colonisation substrata on the rear upright on the flash side.

24.2.3 Amphipod trap

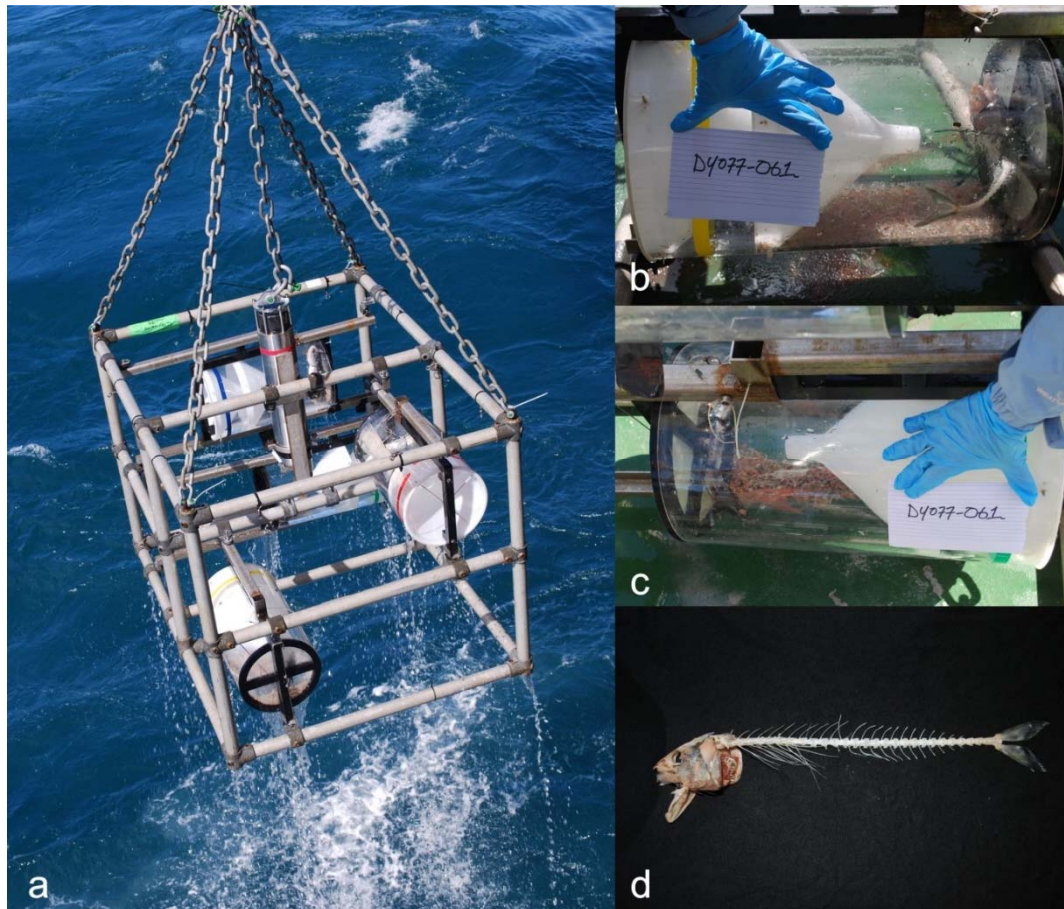
The OBE upgraded DEMAR amphipod trap (carrying four double parlour acrylic traps) was deployed in the conventional manner on two occasions during the cruise. In both cases, all traps were baited with ‘standard British mackerel’. The mooring was of conventional form: lazy float – 15 m polyprop – Billings dan buoy – 15 m polyprop – 6-ball main buoyancy pack – 50 m braid – IXSEA MORS B2S type release. Mooring descent rate was estimated at 60 m min⁻¹, and ascent rate at 38 m min⁻¹.

Summary tabulation of amphipod trap deployments:

Stn number	Start time		Position				End time		Depth (m)	Soak time
			(DD MM.MMM N/W)							
DY077-061	23/04/2017	20:07	49	0.423	16	23.820	25/04/2017	09:07	4846	37 hours
DY077-083	25/04/2017	14:21	49	0.442	16	25.168	28/04/2017	13:48	4846	72 hours

Sample processing: Each trap was photographed with the Station number and then subsequently removed from the frame. Nitrile gloves were used at all times. Each trap position was recorded (top1, top2, bottom1, bottom2), processed and preserved separately. All amphipods were removed from the

trap by gentle washing with filtered seawater (trap cylinder, funnel, mesh). The bait fish was then examined and rinsed. The specimens were then transferred directly to cold ethanol in 1500 ml UN certified plastic bottles and held at -20° C (one bottle per trap).



DY077-061 Amphipod trap, a) trap recovery, b & c) good catches on the lower traps, d) remains of the bait from a lower trap

24.3 Megacorer

The NMFSS Megacorer was used for all coring operations during the cruise. It was rigged and operated in conventional. Monitoring was successfully achieved via a Sonardyne USBL beacon mounted directly on the frame that appeared to produce reliable and precise depth telemetry. Coring positions were all within the 'PAP Central' coring area (500 m radius of nominal centre point, 48° 50.219' N 016° 31.266' W) and selected with the native ArcGIS function 'Create random points'.

The Megacorer was deployed on 10 occasions with 8 large core tubes and 2 small tubes (e.g. MgC08+2) fitted in each case. The lengths of recovered cores were measured and example core profiles were photographed.

24.3.1 Lab processing

Once the cores were removed from the Megacorer they were processed by three teams of two. One person held the core in position while the other sliced the sediment. Details of slicing procedures to acquire the necessary sediment horizons are detailed in Table XX2 and summarised below.

Macrofauna: Macrofauna samples were the priority for the Megacorer deployments. A minimum of four large tubes per deployment were allocated to macrofauna. If fewer than four were available macrofauna samples were not taken. If four were available the remaining cores were allocated to other analyses, with any additional cores allocated to macrofauna.

To process the cores the overlying top water was siphoned into a 250 μm sieve and then transferred into a bottle for 0-1 cm sediment layer (syringes were used when necessary to extract the small volume of remaining water). Slicing rings were used to measure the following horizons: 0.0-1.0 (if the top layer was not flat, the lower part of a slope was used to define the 0-1 cm layer), 1.0-3.0, 3.0-5.0, and 5.0-10.0 cm. Each layer was cut with slicing plate, which was then rinsed (the upper side on the current layer and the downside side used as the top side for the next slice). The top three layers were transferred into the bottle using a funnel. The 5-10 cm layer was placed directly into the small bucket. Rings, funnels and knives were rinsed into the appropriate bottle with filtered seawater.

The 0-1 and 1-3 cm horizons were put in 500 ml UN bottles. 1500 ml UN bottles were used for the 3-5 cm layers and a small (1L) buckets were used for the 5-10 cm layer. Each bottle was labelled on the cap and one side and a paper label was placed inside the bottle. Samples were preserved in 4% formaldehyde ($\frac{1}{2}$ 8% formaldehyde with borax [20 g l^{-1} 40% formaldehyde] $\frac{1}{2}$ sediment / filtered seawater). If the sample filled more than half the volume of a bottle, the overlying water was passed through a 250 μm mesh sieve and the material washed back into the bottle to ensure the correct final formaldehyde concentration.

eDNA: One large core was used for eDNA. All slicing equipment was sterilised in bleach prior to sample processing and washed with Milli-Q between each slice. Nitrile gloves were worn at all stages (new pair for each core). The overlying water was discarded and the following horizons were sliced: 0.0-1.0, 1.0-2.0, 2.0-3.0, 3.0-4.0 and 4.0-5.0 cm. For each 1 cm slice samples of sediment were placed in 3 Whirlpack bags (stored at -80°C). In all cases sediment near the edge of the core was discarded. New sterile spatulas were used for each slice. Slicing plates had been autoclaved prior to each slice. (Further detail is provided in the molecular genetics section).

Biomarkers: One large core was used as a replicate for biomarkers. The top water was discarded. Before slicing and between slices the equipment was rinsed with milli-Q water. Four sections were taken at 0.5 cm horizons to 2 cm. Sediment in contact with the core tube was removed using a knife rinsed in Milli-Q water and the remaining material preserved in muffled foil (preserving as much as possible the integrity of the slice) held inside labelled petri dishes, placed inside a single labelled bag per sample and frozen at -80°C as soon as possible. Nitrile gloves were worn at all stages.

Foraminifera: A small core was used. Before processing and between slices the slicing equipment was washed with filtered seawater. The top 1cm of overlying seawater was passed through 250 μm sieve and added to the 0-0.5 cm sample. The samples were then sliced at 0.5 cm intervals to 2 cm. Each layer was cut with slicing plate, which was then rinsed (the upper side on the current layer and the downside side used as the top side for the next slice). The sediment was preserved in 4% formaldehyde ($\frac{1}{2}$ 8% formaldehyde with borax [20 g l^{-1} 40% formaldehyde] $\frac{1}{2}$ sediment / filtered seawater) and placed into 500 ml UN bottles (blue lids, one for each slice).

Metazoan meiofauna: A small core was used. Before processing and between slices the slicing equipment was washed with filtered seawater. The top five cm of sediment and all sieved top water were retained in 1.5 l plastic bottles and preserved in 4% formaldehyde ($\frac{1}{2}$ 8% formaldehyde with borax [20 g l^{-1} 40% formaldehyde] $\frac{1}{2}$ sediment / filtered seawater).

Microplastics: As soon as the sample was removed from the Megacorer, the large core allocated for microplastics analysis was covered with aluminium foil or a foil-covered bung to avoid plastic contamination. Before processing and between slices the slicing equipment was washed with filtered seawater. Two 1 cm slices were retained: the 0-1 cm (excluding the overlaying water) and the 10-11 cm (as a blank / control). Each slice was placed in a glass jar with a plastic top covered in foil to avoid plastic contamination from the cap. For both slices, no water was added to the samples (the sediment still on plate was taken up with the knife to avoid adding water). Samples were provided to Katsia Pabortsava on board the ship.

Opportunistic live / ethanol preserved sort: When suitable sediment was available from the top 5 cm of cores, material was sieved and live sorted (when time was available, or preserved in ethanol and sorted later in the cruise). The target was high quality specimens of the polychaetes *Aurospio dibranchiata* and *Ophelina abbranchiata* for molecular analysis at the Natural History Museum. Other macrofaunal specimens were also retained. Example opportunities include the edges of eDNA cores, the remainder of foraminifera, biomarker and microplastic cores as well as cases where the sediment had slipped in the core tube or where the surface was too disturbed for other analyses. Samples were sieved through 250µm mesh sieve. Specimens were retained in absolute ethanol at -20°C (findings detailed in Table XX3).

Labelling: All samples were labelled with Cruise ID (DY077), Station number, Date the Megacorer reached the seabed, core ID (for macrofauna only to identify the horizons from the same core tube), sediment horizon, analysis type and preservation method. The outside of every container was labelled (top and side if possible) and a paper label was placed inside the container.

Table XXI: Summary of Megacorer samples collected at the PAP central coring station during DY077

Station	Site	Latitude (N)	Longitude (W)	Depth (m)	Macrofauna	eDNA	Biomarkers	Metazoan meiofauna	Foraminifera	Microplastics	
DY077-016	Core-1	48° 50.246'	016° 31.199'	4845	4	1		1		1	
DY077-020	Core-2	48° 50.431'	016° 31.095'	4845	5	1	1		1		
DY077-021	Core-3	48° 50.438'	016° 31.542'	4844	4	1		1		1	
DY077-056	Core-4	48° 50.309'	016° 31.449'	4844		1	1		1	1	
DY077-057	Core-5	48° 50.225'	016° 31.686'	4844		1			1		
DY077-064	Core-6	48° 50.251'	016° 31.472'	4844	6		1	1		1	
DY077-065*	Core-7	48° 50.363'	016° 31.286'	4844	6	1		2			
DY077-082	Core-8	48° 50.048'	016° 31.379'	4845	4			1	1		
DY077-086	Core-9	48° 50.308'	016° 31.224'	4845		1					
DY077-087	Core-10	48° 50.340'	016° 31.078'	4850	8					2	
* burrow system running through these cores					Replicates	7	7	3	5	4	5
					Total cores	37	7	3	6	4	6

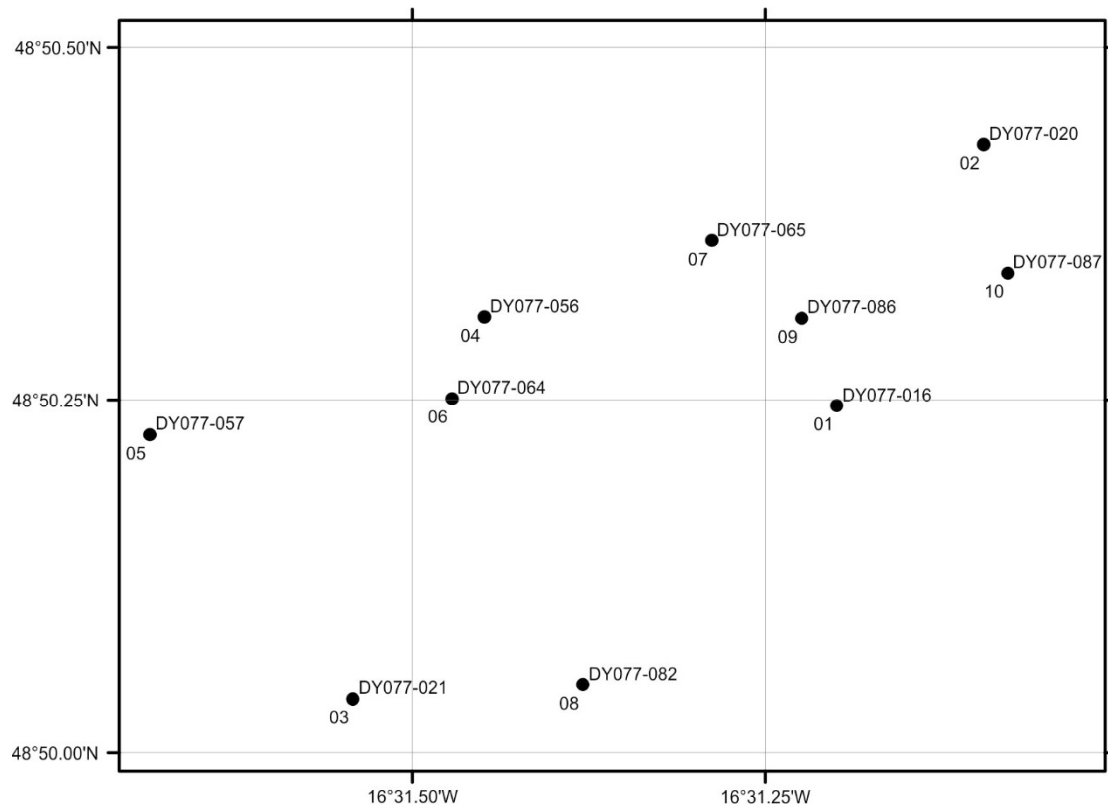
Table XX2: Summary of the Megacore processing protocols

	eDNA	Micro-plastic	Macro-fauna	Bio-markers	Foram-inifera	Metazoan meiofauna
Number of cores per deployment	1	1	Min. 4	1	1	1
Preservation	RNA Later, -80°C	Dried	4% bF	-80°C	4% bF	4% bF
Supernatant	Discarded	Discarded	250 µm sieve, added to first layer	Discarded	250 µm sieve, added to first layer	250 µm sieve, added to first layer
Sections (cm)	0-1	0-1	0-1	0-0.5 0.5-1	0-0.5 0.5-1	0-5
	1-2		1-3	1-1.5 1.5-2	1-1.5 1.5-2	
	2-3					
	3-4		3-5			
	4-5					
			5-10			
			10-11			

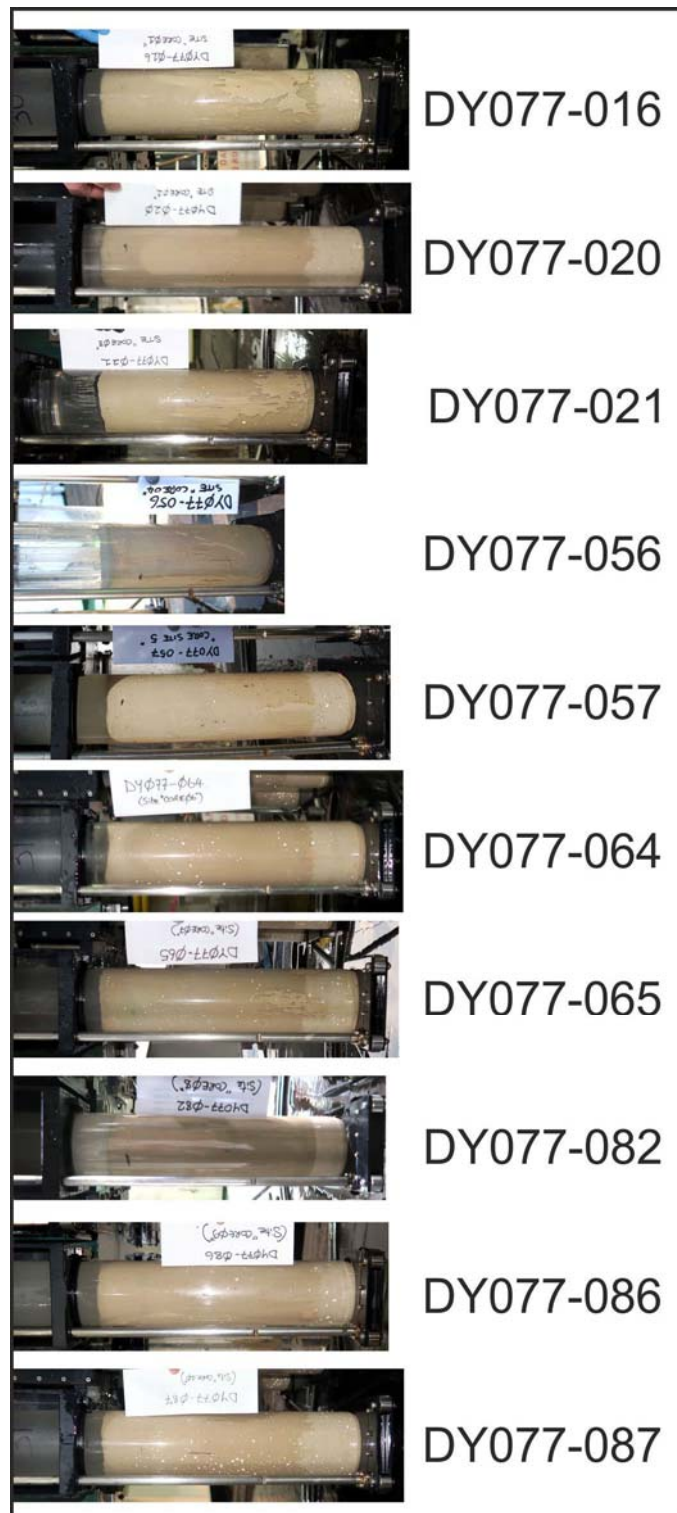
* 4% bF, 4% borax buffered [20 g l⁻¹ 40% formaldehyde] formaldehyde seawater soln.

Table XX3: NHM opportunistically sorted material

Station	Specimen	Preservation
DY077-086	<i>Aurospio abranchiata?</i>	ethanol, -20C
DY077-056	1 x <i>Aurospio dibranchiata</i> & 1 isopoda	ethanol, -20C
DY077-016	<i>Aurospio dibranchiata</i>	ethanol, -20C
DY077-057	1 x isopod, 1 x tanaid	ethanol, -20C
DY077-082	amphipod and bivalve	ethanol, -20C
DY077-086	Xenophyophore (Core 5)	ethanol, -20C



Chartlet showing Megacore stations in the 'PAP Central' coring area labelled by random site number and formal station number.



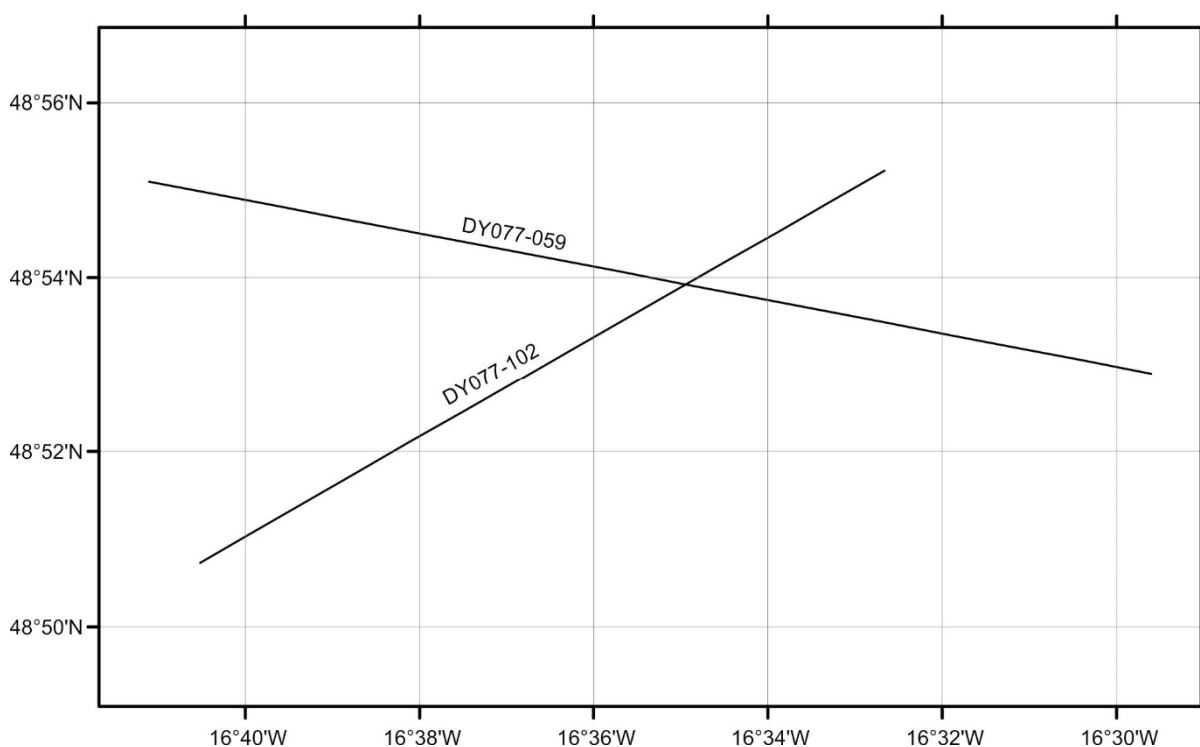
Example core profiles from Megacorer deployments at the “PAP Central” coring location.

24.5 Otter trawl

The NMFSS-supplied OTSB14 (semi-balloon otter trawl, 14m headrope) was rigged and fished in conventional fashion.

Table XX. Summary station metadata.

Station	Date	Seabed start position		Seabed end position		Depth (m)	Dist. fished (km)
		Lat	Long	Lat	Long		
DY077-059	23/04/2017	48° 55.1' N	016° 41.1' W	48° 52.9' N	016° 29.6' W	4844	14.5
DY077-102	27/04/2017	48° 50.7' N	016° 40.5' W	48° 55.2' N	016° 32.7' W	4844	12.6



Chartlet illustrating the approximate seabed tracks fished by the two otter trawls.

Trawl sample processing:

When the first trawl (DY077-059) came on deck there was a large amount of mud in the net (Figure XX 1). The haul was initially hosed with the fire hose for approximately 1 hour to reduce the quantity of sediment, avoiding visible specimens as much as possible. The mud was then spilled into boxes on deck. The second trawl (DY077-102) contained less mud and the contents were spilled directly into

boxes on deck. The catch was then transferred for washing through the sieving table and sorting to broad taxonomic group. The net was then examined in greater detail and large numbers specimens, notably pycnogonids, polychaetes (*Laetmonice* spp.) and anemone (*Iosactis vagabunda*) were added to the catch.

Thick gloves were used during the washing to avoid injury with glass and clinker. Clinker was put aside and photograph for the records as were any litter and artefacts found in the trawl. Specimens were washed and put aside for preservation as soon as possible to ensure the best quality for future identification.

Good quality crustaceans (entire specimens, not too damaged) were preserved in 100 % ethanol, while damaged crustaceans and other taxa were preserved in 4% borax buffered formaldehyde seawater solution. All samples were labelled with Cruise ID (DY077), Station number, Date of the trawl, trawl used (OTSB14) taxa and type of preservative. The outside of every container was labelled (top and side if possible) and a paper label was placed inside the container.

Noelie Benoist took detailed photographs, length, volume and weight measurements for 127 specimens across the two trawls (see section below). These animals were preserved in a separate bag with a specific label. (Rob Young took tissue samples for DNA from most of these specimens see detail elsewhere). Six examples of *Psychropotes*, *Oneirophanta*, *Molpadiodemas* and *Pseudostichopus* were retained and frozen at -80°C for Rachel Jeffreys (University of Liverpool) for stable isotope analysis.

In both trawls the catch was a fairly typical of megabenthic invertebrates from PAP. Holothurians such as *Psychropotes* sp. and *Oneirophanta* sp., actinarians and asteroids (*Styracaster* sp.) were the visual / volume dominants. Note that commensal / parasitic gastropods attached to holothurians or actinarians attached to clinker or with tube worms were not detached but preserved as a whole to minimise damage of the specimens.



DY077-059 OTSB14, the trawl as it came on deck. Note the large quantity of mud



Example images of the catch from DY077-059: Rattails, holothurians, asteroids, actinarians and a cirrate octopod.



DY077-059 a) litter and artefacts, b) clinker



Example images of the catch from DY077-102: Asteroids, actinarians, holothurians, decapods, pycnogonids and a cirriped



Examples of the fish specimens caught in DY077-102, from top: two cut-throat eels, small macrourid, Lizardfish and large macrourid



Litter and artefacts from DY077-102

Table XX4: Samples retain from trawls DY077-059 and DY077-102

Station number	Container label	Container type	Preserv.	Notes
DY077-059	Crustacea	5 L bucket	Ethanol	
DY077-059	Mixed taxa	5 L bucket	4% bF	Last few specimens
DY077-059	Actinaria	10 L bucket	4% bF	
DY077-059	Cephalopoda	10 L bucket	4% bF	RY DNA sample
DY077-059	Crustacea	5 L bucket	4% bF	Not ethanol (end of trawl processing)
DY077-059	Asteroidea (1 of 2)	5 L bucket	4% bF	
DY077-059	Asteroidea (2 of 2)	5 L bucket	4% bF	
DY077-059	Annelida	1500 ml UN	4% bF	
DY077-059	Mollusca	500 ml UN	4% bF	
DY077-059	Jellies	500 ml UN	4% bF	
DY077-059	Fishes	500 ml UN	4% bF	
DY077-059	<i>Psychropotes</i>	Blue barrel	4% bF	
DY077-059	Mixed holothurians	Blue barrel	4% bF	
DY077-059	Mixed holothurians	Blue barrel	4% bF	
DY077-059	Extra for Noelie	5 L bucket	4% bF	
DY077-059	6 x <i>Psychropotes</i> sp.	Plastic bag	Frozen	For Rachel Jeffreys
DY077-059	6 x <i>Oneirophanta</i> sp.	Plastic bag	Frozen	For Rachel Jeffreys
DY077-059	6 x <i>Molpadia</i> sp.	Plastic bag	Frozen	For Rachel Jeffreys
DY077-102	Cirripedia	1500 ml UN	Ethanol	
DY077-102	Crustacea	1500 ml UN	Ethanol	
DY077-102	Crustacea	1500 ml UN	Ethanol	
DY077-102	Actinaria	10 L bucket	4% bF	
DY077-102	Asteroidea	10 L bucket	4% bF	
DY077-102	Noelie Benoist mixed taxa	15 L bucket	4% bF	
DY077-102	Noelie Benoist mixed taxa	15 L bucket	4% bF	
DY077-102	Mollusca	500 ml UN	4% bF	
DY077-102	Annelida	500 ml UN	4% bF	
DY077-102	Gelatinous "Animalia"	500 ml UN	4% bF	
DY077-102	1 of 2 mixed taxa	1500 ml UN	4% bF	Poor quality, end of trawl processing
DY077-102	2 of 2 mixed taxa	1500 ml UN	4% bF	Poor quality, end of trawl processing

DY077-102	Octopoda	1500 ml UN	4% bF	
DY077-102	Pycnogonids & mixed crustacea	1500 ml UN	4% bF	
DY077-102	Tubes	1500 ml UN	4% bF	
DY077-102	Cnidaria, Schyozoa	1500 ml UN	4% bF	
DY077-102	<i>Psychropotes</i>	Blue barrel	4% bF	
DY077-102	<i>Psychropotes</i>	Blue barrel	4% bF	
DY077-102	Mixed holothurians	Blue barrel	4% bF	
DY077-102	Mixed holothurians	Blue barrel	4% bF	
DY077-102	Mixed holothurians	Blue barrel	4% bF	
DY077-102	Mixed holothurians	Blue barrel	4% bF	
DY077-102	Fish - <i>Bathysaurus</i>	Blue barrel	4% bF	RY DNA samples
DY077-102	6 x <i>Pseudostichopus</i>	Plastic bag	Frozen	For Rachel Jeffreys

24.5.1 Body measurement of trawl-caught benthic specimen

Noëlie M.A. Benoist

A subset of the trawl-caught benthic megafauna collected from the OTSB14 were sampled for individual fresh body measurement. Only those complete and ‘most intact’ specimen (i.e. not punctured, including all ‘legs’ / appendages) were selected. In total, 127 individuals (29 taxa over 6 phyla: Annelida, Arthropoda, Cnidaria, Echinodermata, Sipuncula) were picked.

Photography. Specimen were individually photographed in a tray next to a ruler using a Fine Pix F550EXR FUJIFILM camera (4608 x 3456 pixels). They were placed in their *in situ* position; as if they were observed using a downward-orientated camera (e.g. the tail of squat lobsters remained underneath their body, shrimps and anemones were sited to view their dorsal side and oral disc, respectively). Close-up photographs were also taken to capture morphological details.

Fresh body weight. Individual fresh body wet weight (*fwwt*, g) was measured to the nearest 0.1 g using a Marine Scale S/V-182 (Program ver.3.58). Excess of water was quickly absorbed with tissue prior to weighing. Recorded weights ranged between c. 0.4 (*Iosactis vagabunda*) and c. 1300 g (*Psychropotes* sp.).

Fresh body volume. Individual fresh body volume (*v*, ml) was measured to the nearest 0.5, 5, or 10 ml, by placing an individual into a measuring cylinder (100, 250, 1000, or 2000 ml, depending on its size) previously filled with seawater: $v = \text{volume including individual} - \text{initial volume without individual}$. Recorded volumes ranged between 0.5 (*Iosactis vagabunda*) and 1210 ml (*Psychropotes longicauda*).

25 Appendix 1: CTD Configuration Files

Config file for casts 001-003

Instrument configuration file: C:\Users\sandm\Documents\Cruises\DY077\Data\Seasave Setup Files\DY077_0943_SS.xmlcon

Configuration report for SBE 911plus/917plus CTD

Frequency channels suppressed : 0
Voltage words suppressed : 0
Computer interface : RS-232C
Deck unit : SBE11plus Firmware Version >= 5.0
Scans to average : 1
NMEA position data added : Yes
NMEA depth data added : No
NMEA time added : Yes
NMEA device connected to : PC
Surface PAR voltage added : No
Scan time added : Yes

1) Frequency 0, Temperature

Serial number : 03P-2674
Calibrated on : 12-Apr-2016
G : 4.35704908e-003
H : 6.42890429e-004
I : 2.39495498e-005
J : 2.41492992e-006
F0 : 1000.000
Slope : 1.00000000
Offset : 0.0000

2) Frequency 1, Conductivity

Serial number : 04C-2571
Calibrated on : 17-Sept-2015
G : -9.93506765e+000
H : 1.54127601e+000
I : 1.31909516e-004
J : 9.53663714e-005
CTcor : 3.2500e-006
CPcor : -9.57000000e-008
Slope : 1.00000000
Offset : 0.00000

3) Frequency 2, Pressure, Digiquartz with TC

Serial number : 110557
Calibrated on : 3-Nov-2016
C1 : -6.010548e+004
C2 : -1.565601e+000
C3 : 1.823090e-002
D1 : 2.668300e-002
D2 : 0.000000e+000
T1 : 3.020528e+001
T2 : -6.718318e-004
T3 : 4.457980e-006
T4 : 1.203850e-009
T5 : 0.000000e+000
Slope : 0.99999952
Offset : -0.09301
AD590M : 1.280700e-002
AD590B : -9.299640e+000

4) Frequency 3, Temperature, 2

Serial number : 03P-4383
Calibrated on : 17-Feb-2016
G : 4.39869867e-003

H : 6.55422307e-004
I : 2.42112171e-005
J : 2.00242732e-006
F0 : 1000.000
Slope : 1.00000000
Offset : 0.0000

5) Frequency 4, Conductivity, 2

Serial number : 04C-2580
Calibrated on : 18-Feb-2016
G : -1.04721262e+001
H : 1.53914981e+000
I : 5.50311670e-004
J : 4.36265174e-005
CTcor : 3.2500e-006
CPcor : -9.57000000e-008
Slope : 1.00000000
Offset : 0.00000

6) A/D voltage 0, Oxygen, SBE 43

Serial number : 43-1624
Calibrated on : 10-Mar-2016
Equation : Sea-Bird
Soc : 5.63600e-001
Offset : 5.15900e-001
A : -5.25030e-003
B : 2.37880e-004
C : -3.44350e-006
E : 3.60000e-002
Tau20 : 1.03000e+000
D1 : 1.92634e-004
D2 : -4.64803e-002
H1 : -3.30000e-002
H2 : 5.00000e+003
H3 : 1.45000e+003

7) A/D voltage 1, Free

8) A/D voltage 2, Altimeter

Serial number : 59494

Calibrated on :

Scale factor : 1.000

Offset : 0.000

9) A/D voltage 3, OBS, WET Labs, ECO-BB

Serial number : 169

Calibrated on : 08-Sept-2016

ScaleFactor : 0.005228

Dark output : 0.089000

10) A/D voltage 4, PAR/Irradiance, Biospherical/Licor

Serial number : 70510

Calibrated on : 24-Jan-2017

M : 1.00000000

B : 0.00000000

Calibration constant : 20449897800.00000000

Multiplier : 1.00000000

Offset : -0.04979765

11) A/D voltage 5, PAR/Irradiance, Biospherical/Licor, 2

Serial number : 70520

Calibrated on : 24-Jan-2017

M : 1.00000000

B : 0.00000000

Calibration constant : 16835016800.00000000

Multiplier : 1.00000000

Offset : -0.06092372

12) A/D voltage 6, Transmissometer, WET Labs C-Star

Serial number : CST-1602DR

Calibrated on : 24-May-2016

M : 2.1304

B : -0.1065

Path length : 0.250

13) A/D voltage 7, Fluorometer, Chelsea Aqua 3

Serial number : 88-2615-126

Calibrated on : 22-July-2016

VB : 0.210900

V1 : 2.156000

Vacetone : 0.303700

Scale factor : 1.000000

Slope : 1.000000

Offset : 0.000000

Scan length : 45

Pump Control

This setting is only applicable to a custom build of the SBE 9plus.

Enable pump on / pump off commands: NO

Data Acquisition:

Archive data: YES

Delay archiving: NO

Data archive: C:\Users\sandm\Documents\Cruises\DY077\Data\CTD Raw

Data\DY077_Cast_023.hex

Timeout (seconds) at startup: 60

Timeout (seconds) between scans: 20

Instrument port configuration:

Port = COM4

Baud rate = 19200

Parity = N

Data bits = 8

Stop bits = 1

Water Sampler Data:

Water Sampler Type: SBE Carousel

Number of bottles: 24

Port: COM5

Enable remote firing: NO

Firing sequence: User input

Tone for bottle fire confirmation uses PC sound card.

Header information:

Header Choice = Prompt for Header Information

prompt 0 = Ship: RRS *Discovery*

prompt 1 = Cruise: DY077

prompt 2 = Cast:

prompt 3 = Station:

prompt 4 = Julian Day:

prompt 5 = Date:

prompt 6 = Time:

prompt 7 = Latitude:

prompt 8 = Longitude:

prompt 9 = Depth (uncorr m):

prompt 10 = Principal Scientist: Richard Lampitt (NOCS)

prompt 11 = Operator:

TCP/IP - port numbers:

Data acquisition:

Data port: 49163

Status port: 49165

Command port: 49164

Remote bottle firing:

Command port: 49167

Status port: 49168

Remote data publishing:

Converted data port: 49161

Raw data port: 49160

Miscellaneous data for calculations

Depth, Average Sound Velocity, and TEOS-10

Latitude when NMEA is not available: 58.900000

Longitude when NMEA is not available: 0.000000

Average Sound Velocity

Minimum pressure [db]: 20.000000

Minimum salinity [psu]: 20.000000

Pressure window size [db]: 20.000000

Time window size [s]: 60.000000

Descent and Acceleration

Window size [s]: 2.000000

Plume Anomaly

Theta-B: 0.000000

Salinity-B 0.000000

Theta-Z / Salinity-Z 0.000000

Reference pressure [db] 0.000000

Oxygen

Window size [s]: 2.000000

Apply hysteresis correction: 1

Apply Tau correction: 1

Potential Temperature Anomaly

A0: 0.000000

A1: 0.000000

A1 Multiplier: Salinity

Serial Data Output:

Output data to serial port: YES

Seconds between updates: 0.000000

Port = COM3

Baud rate = 9600

Parity = N

Data bits = 8

Stop bits = 1

Variables:

Digits Variable Name [units]

- 1 Depth [salt water, m]
- 1 Pressure, Digiquartz [db]
- 4 Temperature [ITS-90, deg C]
- 4 Temperature, 2 [ITS-90, deg C]
- 4 Temperature Difference, 2 - 1 [ITS-90, deg C]
- 4 Conductivity [mS/cm]
- 4 Conductivity, 2 [mS/cm]
- 4 Conductivity Difference, 2 - 1 [mS/cm]
- 4 Salinity, Practical [PSU]
- 4 Salinity, Practical, 2 [PSU]
- 4 Salinity, Practical, Difference, 2 - 1 [PSU]
- 1 Oxygen, SBE 43 [% saturation]
- 2 Oxygen, SBE 43 [umol/kg]
- 5 Beam Transmission, WET Labs C-Star [%]

Mark Variables:

No variables are selected.

Shared File Output:

Output data to shared file: NO

TCP/IP Output:

Raw data:

- Output raw data to socket: NO
- XML wrapper and settings: NO
- Seconds between raw data updates: 0.000000

Converted data:

- Output converted data to socket: NO
- XML format: NO

SBE 11plus Deck Unit Alarms

- Enable minimum pressure alarm: NO
- Enable maximum pressure alarm: NO
- Enable altimeter alarm: NO

SBE 14 Remote Display

- Enable SBE 14 Remote Display: NO

PC Alarms

Enable minimum pressure alarm: NO

Enable maximum pressure alarm: NO

Enable altimeter alarm: NO

Enable bottom contact alarm: NO

Alarm uses PC sound card.

Options:

Prompt to save program setup changes: YES

Automatically save program setup changes on exit: NO

Confirm instrument configuration change: YES

Confirm display setup changes: YES

Confirm output file overwrite: YES

Check scan length: YES

Compare serial numbers: YES

Maximized plot may cover Seasave: NO

[Config file for casts 004 onwards](#)

Report - Page 1 of 3

Date: 04/29/2017

Instrument configuration file: C:\Users\sandm\Documents\Cruises\DY077\Data\Seasave
Setup Files\DY077_1158_SS.xmlcon

Configuration report for SBE 911plus/917plus CTD

Frequency channels suppressed : 0

Voltage words suppressed : 0

Computer interface : RS-232C

Deck unit : SBE11plus Firmware Version >= 5.0

Scans to average : 1

NMEA position data added : Yes

NMEA depth data added : No

NMEA time added : Yes

NMEA device connected to : PC

Surface PAR voltage added : No

Scan time added : Yes

1) Frequency 0, Temperature

Serial number : 03P-2674

Calibrated on : 12-Apr-2016

G : 4.35704908e-003

H : 6.42890429e-004

I : 2.39495498e-005

J : 2.41492992e-006

F0 : 1000.000

Slope : 1.00000000

Offset : 0.0000

2) Frequency 1, Conductivity

Serial number : 04C-2571

Calibrated on : 17-Sept-2015

G : -9.93506765e+000

H : 1.54127601e+000

I : 1.31909516e-004

J : 9.53663714e-005

CTcor : 3.2500e-006

CPcor : -9.57000000e-008

Slope : 1.00000000

Offset : 0.00000

3) Frequency 2, Pressure, Digiquartz with TC

Serial number : 110557

Calibrated on : 3-Nov-2016

C1 : -6.010548e+004

C2 : -1.565601e+000

C3 : 1.823090e-002

D1 : 2.668300e-002

D2 : 0.000000e+000

T1 : 3.020528e+001

T2 : -6.718318e-004

T3 : 4.457980e-006

T4 : 1.203850e-009

T5 : 0.000000e+000

Slope : 0.99999952

Offset : -0.09301
AD590M : 1.280700e-002
AD590B : -9.299640e+000
4) Frequency 3, Temperature, 2
Serial number : 03P-4383
Calibrated on : 17-Feb-2016
G : 4.39869867e-003
H : 6.55422307e-004
I : 2.42112171e-005
J : 2.00242732e-006
F0 : 1000.000
Slope : 1.00000000
Offset : 0.0000

Report - Page 2 of 3

5) Frequency 4, Conductivity, 2
Serial number : 04C-2580
Calibrated on : 18-Feb-2016
G : -1.04721262e+001
H : 1.53914981e+000
I : 5.50311670e-004
J : 4.36265174e-005
CTcor : 3.2500e-006
CPcor : -9.57000000e-008
Slope : 1.00000000
Offset : 0.0000

6) A/D voltage 0, Oxygen, SBE 43
Serial number : 43-2818
Calibrated on : 28-JUL-2016
Equation : Sea-Bird
Soc : 4.62400e-001
Offset : -5.00900e-001
A : -4.51140e-003
B : 2.43630e-004
C : -3.66650e-006
E : 3.60000e-002
Tau20 : 1.54000e+000
D1 : 1.92634e-004

D2 : -4.64803e-002
H1 : -3.30000e-002
H2 : 5.00000e+003
H3 : 1.45000e+003
7) A/D voltage 1, Free
8) A/D voltage 2, Altimeter
Serial number : 59494
Calibrated on :
Scale factor : 15.000
Offset : 0.000
9) A/D voltage 3, OBS, WET Labs, ECO-BB
Serial number : 169
Calibrated on : 08-Sept-2016
ScaleFactor : 0.005228
Dark output : 0.089000
10) A/D voltage 4, PAR/Irradiance, Biospherical/Licor
Serial number : 70510
Calibrated on : 24-Jan-2017
M : 1.00000000
B : 0.00000000
Calibration constant : 20449897800.00000000
Multiplier : 1.00000000
Offset : -0.04979765
11) A/D voltage 5, PAR/Irradiance, Biospherical/Licor, 2
Serial number : 70520
Calibrated on : 24-Jan-2017
M : 1.00000000
B : 0.00000000
Calibration constant : 16835016800.00000000
Multiplier : 1.00000000
Offset : -0.06092372
12) A/D voltage 6, Transmissometer, WET Labs C-Star
Serial number : CST-1602DR
Calibrated on : 24-MAY-2016
M : 21.3000
B : -0.0800
Path length : 0.250

13) A/D voltage 7, Fluorometer, Chelsea Aqua 3

Report - Page 3 of 3

Serial number : 88-2615-126

Calibrated on : 22-JUL-2016

VB : 0.210900

V1 : 2.156000

Vacetone : 0.303700

Scale factor : 1.000000

Slope : 1.000000

Offset : 0.000000

Scan length : 45

26 Station List

Station	Gear	"Start"		Latitude			Longitude			"End"		Latitude			Longitude			Sounding (m)	Comment 1	Comment 2
		Date	Time	dd	mm.mmm	N	dd	mm.mmm	W	Depth	Date	Time	dd	mm.mmm	N	dd	mm.mmm			
DY077-001	CTD	16/04/2017	20:22	49	3.263	16	20.378	0	16/04/2017	21:22	49	3.263	16	20.368	103	4833	All bottles fired (21)			
DY077-002	MSC	16/04/2017	20:46	49	3.263	16	20.367	0	16/04/2017	20:46	49	3.263	16	20.368	350	4830	Successful			
DY077-003	MSC	16/04/2017	21:34	49	3.263	16	20.368	0	16/04/2017	21:34	49	3.263	16	20.368	350	4829	Successful			
DY077-004	MSC	16/04/2017	22:03	49	3.263	16	20.368	0	16/04/2017	22:03	49	3.263	16	20.368	350	4829	Successful			
DY077-005	CTD	16/04/2017	22:25	49	3.262	16	20.367	0	16/04/2017	22:51	49	3.262	16	20.367	30	4829	All bottles fired (21)			
DY077-006	MSC	16/04/2017	22:41	49	3.262	16	20.369	0	16/04/2017	21:41	49	3.262	16	20.367	350	4829	Successful			
DY077-007	CTD	17/04/2017	00:31	49	3.260	16	20.370	0	17/04/2017	05:11	49	3.262	16	20.370	4784	4828	All bottles fired (21)	Wire tested releases		
DY077-008	NBST	17/04/2017	05:30	49	3.262	16	20.371	0								4830	Tethered buoyancy check			
DY077-009	NBST	17/04/2017	05:50	49	3.261	16	20.371	0									4830	Tethered buoyancy check		
DY077-010	NBST	17/04/2017	06:10	49	3.262	16	20.370	0									4830	Tethered buoyancy check		
DY077-011	NBST	17/04/2017	06:30	49	3.262	16	20.371	0									4830	Tethered buoyancy check		
DY077-012	NBST	17/04/2017	06:50	49	3.262	16	20.371	0									4830	Tethered buoyancy check		
DY077-013	NBST	17/04/2017	07:10	49	3.262	16	20.370	0									4830	Tethered buoyancy check		
DY077-014	NBST	17/04/2017	07:30	49	3.263	16	20.371	0									4830	Tethered buoyancy check		
DY077-015	NBST	17/04/2017	07:50	49	3.268	16	20.376	0									4830	Tethered buoyancy check		
DY050-057	PAP1	28/04/2016	10:26	49	2.153	16	20.362		17/04/2017	10:00	49	2.153	16	20.362			4846	ODAS and frame recovered	Mooring buoyed off	
DY077-016	MgC08+2	17/04/2017	19:01	48	50.246	16	31.199	4845									4845	7/10 good cores		
DY077-017	WP2	17/04/2017	23:09	48	50.247	16	31.187	0	17/04/2017	23:38	48	50.279	16	31.147	180		4842	Good catch		
DY077-018	WP2	18/04/2017	00:05	48	50.274	16	31.146	0	18/04/2017	00:41	48	50.274	16	31.146	180		4842	Good catch		
DY077-019	PAP1	18/04/2017							18/04/2017	15:12	49	2.153	16	20.362			4846	Position identical to DY050-057		
DY077-020	MgC08+2	18/04/2017	20:00	48	50.431	16	31.095	4845									4845	8/10 good cores		
DY077-021	MgC08+2	19/04/2017	00:06	48	50.038	16	31.542	4844									4844	7/10 good cores		
DY077-022	Pelagra-7	19/04/2017	04:15	48	58.872	16	21.758	350	21/04/2017	17:00	49	12.48	16	37.260	350		4844	1 full length flux + gel	OK- process cup #2	
DY077-023	Pelagra-9	19/04/2017	04:40	48	58.972	16	21.613	350	21/04/2017	18:16	49	9.48	16	38.460	350		4844	2 half length flux	process only second/late cup #2	
DY077-024	Pelagra-4	19/04/2017	04:45	48	58.996	16	21.579	200	21/04/2017	21:28	49	26.220	16	54.840	200		4844	1 full length flux + gel	aborted early no samples	
DY077-025	Pelagra-8	19/04/2017	05:00	48	59.069	16	21.473	200	21/04/2017	22:43	49	37.680	16	55.860	200		4844	2 half length flux	aborted early no samples	
DY077-026	NBST-200	19/04/2017	05:19	48	59.180	16	21.313	200	21/04/2017	18:10	49	9.336	16	37.986	200		4844	3 flux + 1 gel	OK	
DY077-027	NBST-020	19/04/2017	05:34	48	59.269	16	21.184	200	19/04/2017	19:27	49	2.724	16	26.364	350		4844	3 flux + 1 gel	aborted early no samples	
DY077-028	NBST-021	19/04/2017	05:47	48	59.348	16	21.071	350	lost								4844	3 flux + 1 gel	lost	
DY077-029	NBST-022	19/04/2017	06:00	48	59.428	16	20.956	350	19/04/2017	19:36	49	2.730	16	26.404	350		4844	3 flux + 1 gel	aborted early no samples	
DY077-030	STT	19/04/2017	07:59	48	59.578	16	20.430	350	21/04/2017	16:00	49	14.532	16	40.526	350		4845	4 flux + 1 gel at each depth	OK- tops open on 350m NBST tubes	
DY077-031	CTD	19/04/2017	08:56	48	59.629	16	19.484	350	19/04/2017	09:47	48	59.629	16	19.484	350		4845	Bottles not closed		
DY077-032	ISC	19/04/2017	10:39	48	59.629	16	19.484	0	19/04/2017	10:39	48	59.600	16	19.500	400		4845	All good		
DY077-033	CTD	19/04/2017	12:18	48	57.143	16	25.877	0	19/04/2017	13:13	48	57.170	16	25.930	350		4844	All bottles fired (21)		
DY077-034	ISC	19/04/2017	13:34	48	57.170	16	25.929	0	19/04/2017	13:34	48	57.470	16	25.930	400		4844	All good		
DY077-035	CTD	19/04/2017	15:17	49	1.541	16	25.788	0	19/04/2017	16:04	49	1.542	16	25.788	350		4846	All bottles fired (21)		
DY077-036	ISC	19/04/2017	16:21	49	1.542	16	25.788	0	19/04/2017	16:21	49	1.540	16	25.790	400		4846	All good		
DY077-037	RCF	19/04/2017	16:50	49	1.543	16	25.788	0	19/04/2017	16:50	49	1.540	16	25.790	300		4846	All good		
DY077-038	SAPS-M	19/04/2017	23:30	48	59.012	16	29.717	350	20/04/2017	02:30	48	59.012	16	29.717	350		4842	pumps at 200 and 350 m	2 hr pump time. Vol: 894.1 L at 350m; 787.0 at	
DY077-039	WP2	20/04/2017	03:12	48	59.012	16	29.717	0	20/04/2017	03:12	48	59.012	16	29.718	180		4842	poor catch - too long after midnight?		
DY077-040	PAP3	20/04/2017	11:53	49	0.152	16	27.369	0									4845	Sediment traps and colonisation substrata	Triangulated position 49 00.3 N 016 27.9 W	
DY077-041	ISC	20/04/2017	15:40	48	59.170	16	27.859	0	20/04/2017	15:40	48	59.220	16	28.290	400		4844	All good		
DY077-042	SAPS-O	20/04/2017	17:00	48	59.222	16	28.299	10	20/04/2017	07:12	48	59.222	16	28.299	500		4844	SAPS at 150m failed, 10 and 500m ok		
DY077-043	RCF	20/04/2017	18:50	48	59.222	16	28.299	0	20/04/2017	19:30	48	58.170	16	28.090	300		4844	All good		
DY077-044	MSC	20/04/2017	20:30	48	59.209	16	28.203	0	20/04/2017	20:28	48	58.170	16	28.090	350		4846	All good		
DY077-045	MSC	20/04/2017	20:52	48	59.210	16	28.202	0	20/04/2017	20:52	48	58.170	16	28.090	350		4846	All good		
DY077-046	MSC	20/04/2017	21:12	48	59.211	16	28.204	0	20/04/2017	21:12	48	58.170	16	28.090	40		4846	Leaking		
DY077-047	MSC	20/04/2017	21:23	48	59.210	16	28.202	0	20/04/2017	21:23	48	58.170	16	28.090	40		4846	Leaking		
DY077-048	CTD	20/04/2017	22:10	48	58.129	16	28.075	0	21/04/2017	01:56	48	58.127	16	28.076	4822	4845	All bottles fired (21)			

DY077-049	CTD	21/04/2017	05:19	49	7.054	16	37.023	0	21/04/2017	06:21	49	7.055	16	37.024	350	3982	All bottles fired (21)					
DY077-050	ISC	21/04/2017	06:40	49	7.056	16	37.023	0	21/04/2017	06:40	49	7.060	16	37.020	500	3982	All good					
DY077-051	CTD	21/04/2017	08:50	49	11.291	16	42.041	0	21/04/2017	09:38	49	11.288	16	42.032	350	4846	All bottles fired (21)					
DY077-052	ISC	21/04/2017	10:00	49	11.288	16	42.029	0	21/04/2017	10:01	49	11.280	16	42.030	600	4846	All good					
DY077-053	MSC	21/04/2017	10:30	49	11.287	16	42.029	40	21/04/2017	10:34	49	11.280	16	42.030	40	4846	All good					
DY077-054	MSC	21/04/2017	10:42	49	11.288	16	42.032	40	21/04/2017	10:47	49	11.280	16	42.030	40	4846	All good					
DY077-055	CTD	21/04/2017	12:38	49	12.054	16	34.000	0	21/04/2017	13:20	49	12.053	16	33.997	350	4847	All bottles fired (21)					
DY077-056	MgC08+2	22/04/2017	09:36	48	50.309	16	31.449	4844								4844	4/10 good cores					
DY077-057	MgC08+2	22/04/2017	13:47	48	50.225	16	31.686	4844									4844	2/10 good cores				
DY077-058	CTD	22/04/2017	16:23	48	50.146	16	31.280	0	22/04/2017	17:14	48	50.150	16	31.280	100	4842	All bottles fired (21)					
DY077-059	OTSB14a	23/04/2017	01:00	48	55.100	16	41.100	4843	23/04/2017	05:30	48	52.900	16	29.600	4846	4844	Large mass of mud; fair catch	Distance run c. 14.5 km				
DY077-060	CTD	23/04/2017	11:58	49	0.390	16	23.865	0	23/04/2017	12:30	49	0.390	16	23.864	350	4847	All bottles fired (21)					
DY050-025	PAP3	24/04/2016	13:31	49	0.443	16	29.539	3000	23/04/2017	17:30							Recovery of sediment trap mooring					
DY077-061	ATRAP	23/04/2017	20:07	49	0.423	16	23.820	4846	25/04/2017	09:07	49	0.423	16	23.820	4846	4846	Good catches in bottom traps	Soak time = 37 hours				
DY077-062	WP2	23/04/2017	22:37	48	50.241	16	31.473	200	25/04/2017	23:04	48	50.241	16	31.472	180	4846	samples preserved in formalin					
DY077-063	WP2	23/04/2017	23:07	48	50.242	16	31.472	200	25/04/2017	23:31	48	50.241	16	31.472	180	4846	samples sieved and frozen					
DY077-064	MgC08+2	24/04/2017	01:26	48	50.251	16	31.472	4844									4844	10/10 good cores (1 lost later)				
DY077-065	MgC08+2	24/04/2017	05:23	48	50.363	16	31.288	4844										4844	9/10 good cores			
DY077-066	STT	24/04/2017	09:26	48	57.511	16	19.330	350	27/04/2017	08:30	48	49.188	16	42.792	350	4842	2 NBST flux, 1 gel tube closed, 2 NBST flux open, 2 Lamborg flux open					
DY077-067	Pelagra-4	24/04/2017	10:00	48	57.516	16	19.427	350	27/04/2017	04:00	48	50.1	16	36.700	350	4842	1 full length flux + gel	OK				
DY077-068	Pelagra-7	24/04/2017	10:15	48	57.600	16	19.404	350	27/04/2017	04:20	48	50	16	36.200	350	4842	1 full length flux + gel	OK				
DY077-069	Pelagra-6	24/04/2017	10:30	48	57.504	16	19.681	350	lost									350	1 half flux + gel	trap lost		
DY077-070	Pelagra-9	24/04/2017	10:45	48	57.455	16	19.868	350	27/04/2017	05:20	48	51.1	16	38.300	350	4844	1 half flux + gel	OK				
DY077-071	NBST-020	24/04/2017	11:08	48	57.513	16	19.853	350	24/04/2017	21:16	48	55.37508	16	27.049	350	4844	3 flux + 1 gel	aborted early no samples				
DY077-072	NBST-022	24/04/2017	11:19	48	57.561	16	19.882	350	27/04/2017	04:33	48	50.1	16	35.400	350	4844	3 flux + 1 gel	trap lost				
DY077-073	NBST-200	24/04/2017	11:34	48	57.630	16	19.920	350	lost									350	3 flux + 1 gel	OK		
DY077-074	CTD	24/04/2017	12:35	48	56.348	16	15.744	350										350	4844	9 bottles fired	CTD 13	
DY077-075	CTD	24/04/2017	14:06	48	56.348	16	15.745	0										100	4844	Aborted; depth / pressure mismatch?		
DY077-076	ISC	24/04/2017	14:30	48	56.348	16	15.746	0	24/04/2017	14:30	56	35.000	16	15.740	500	4844	All good					
DY077-077	CTD	24/04/2017	15:41	48	56.348	16	15.745	0										415	4844	All bottles fired (21)	CTD 15 concerns with winch meters out, led to	
DY077-078	CTD	24/04/2017	17:43	48	59.790	16	22.083	0	24/04/2017	18:30	48	59.790	16	22.083	350	4844	All bottles fired (21) ?					
DY077-079	CTD	24/04/2017	19:33	48	54.396	16	23.711	0	24/04/2017	20:18	48	54.395	16	23.710	350	4842	All bottles fired (21)					
DY077-080	ISC	24/04/2017	22:08	48	53.290	16	30.560	0	24/04/2017	22:50	48	54.890	16	26.801	400	4842	All good					
DY077-081	ISC	25/04/2017	00:27	48	58.005	16	26.582	0	26/04/2017	23:46	48	58.000	16	26.580	400	4844	All good					
DY077-082	MgC08+2	25/04/2017	03:40	48	50.048	16	31.379	4845											4845	6/10 good cores		
DY077-083	ATRAP	25/04/2017	14:21	49	0.442	16	25.168	4846	28/04/2017	13:48	49	0.387	16	23.866	4846	4846	Good catches	Soak time = 71.5 hours				
DY077-084	BSNAP	25/04/2017	16:03	49	0.387	16	23.866	4846											4846	8-hr intervals, and colonisation substrata	s/n 686 ARM 160D REL 1655	
DY077-085	CTD	25/04/2017	14:19	48	59.329	16	23.733	0	25/04/2017	18:16	48	59.329	16	23.732	4829	4846	All bottles fired (21)					
DY077-086	MgC08+2	25/04/2017	22:34	48	50.308	16	31.224	4843												4843	1/10 good cores	
DY077-087	MgC08+2	26/04/2017	01:53	48	50.340	16	31.078	4843												4843	10/10 good cores, no USBL data	
DY077-088	SAPS-M	26/04/2017	08:00	48	51.933	16	35.442	200											350	4842	pumps at 200 and 350 m	2 hr pump time. Vol: 884.5 L at 350m; 871.1 at
DY077-089	CTD	26/04/2017	11:55	48	52.072	16	35.172	0	26/04/2017	12:42	48	52.072	16	35.172	350	4844	All bottles fired (21)					
DY077-090	ISC	26/04/2017	13:05	48	52.072	16	35.173	0	26/04/2017	13:02	48	52.072	16	35.172	500	4845	All good					
DY077-091	CTD	26/04/2017	14:53	48	54.884	16	42.144	0	26/04/2017	15:32	48	54.886	16	42.145	350	4841	All bottles fired (21)					
DY077-092	MSC	26/04/2017	14:55	48	54.885	16	42.145	350	26/04/2017	14:55	48	54.880	16	42.145	350	4840	All good					
DY077-093	MSC	26/04/2017	15:22	48	54.885	16	42.145	350	26/04/2017	15:22	48	54.880	16	42.145	350	4840	All good					
DY077-094	MSC	26/04/2017	15:53	48	54.884	16	42.146	350	26/04/2017	15:53	48	54.880	16	42.145	70	4840	All good					
DY077-095	ISC	26/04/2017	16:01	48	54.884	16	42.146	0	26/04/2017	16:01	48	54.880	16	42.145	500	4840	Did not record images					
DY077-096	MSC	26/04/2017	16:07	48	54.884	16	42.146	0	26/04/2017	16:07	48	54.880	16	42.140	70	4840	All good					
DY077-097	CTD	26/04/2017	18:00	48	49.531	16	42.287	350	26/04/2017	18:00	48	49.530	16	42.288	350	4840	All bottles fired (21)					
DY077-098	RCF	26/04/2017	18:10	48	49.531	16	42.288	0	26/04/2017	18:11	48	49.530	16	42.288	300	4840	All good					
DY077-099	SAPS-O	26/04/2017	20:00	48	49.531	16	42.288	10	26/04/2017	21:02	48	49.531	16	42.288	1000	4840	SAPS at 500m failed, 10m, 150m, 1000m ok					
DY077-100	ISC	26/04/2017	22:42	48	49.493	16	42.418	0	27/04/2017	21:51	48	49.490	16	42.420	500	4839	All good					
DY077-101	METCAL	26/04/2017	23:00	48	49.484	16	42.404	0											0	4839	Met. sensor calibration	
DY077-102	OTSB14a	27/04/2017	15:28	48	50.727	16	40.515	4840	27/04/2017	17:50	48	55.227	16	32.659	4847	4844	Good catch	Distance run c. 12.6 km				
DY077-103	ISC	28/04/2017	06:42	48	47.118	16	46.795	0	28/04/2017	06:42	48	47.120	16	46.750	500	4842	All good					
DY077-104	RCF	28/04/2017	07:45	48	47.120	16	46.796	0	28/04/2017	07:47	48	47.120	16	46.750	300	4841	All good					
DY077-105	CTD	28/04/2017	08:46	48	47.119	16	46.796	0	28/04/2017	08:46	48	47.119	16	46.795	1000	4840	All bottles fired (21)					
DY077-106	CTD	28/04/2017	10:56	48	49.922	16	40.479	350	28/04/2017	10:56	48	49.923	16	40.496	350	4838	All bottles fired (21)					
DY077-107	WP2	28/04/2017	14:19	49	0.843	16	24.620	200	28/04/2017	15:02	49	0.866	16	24.650	180	4846	samples sieved and frozen					
DY077-108	WP2	28/04/2017	15:07	49	0.866	16	24.654	200	28/04/2017	15:36	49	0.866	16	24.654	180	4846	samples preserved in formalin					

GEAR	Description	Metadata notes
ATRAP	Amphipod trap, "DEMAR" type, four near-bottom, double parlour traps	Times given are estimated arrivals / departures from seabed
BSNAP	"Bathysnap", time-lapse camera system [new Kongsberg camera and flash, Oceanlab Oceanback]	Times given are estimated arrivals / departures from seabed
CTD	Conductivity, temperature, depth etc. instrument	Time and position refer to start and end of cast, depths refer to min. and max. of profile
ISC	In situ camera system	
METCAL	Meteorological sensor calibration	
MgCxx+y	Bowers & Connelly Megacorer fitted with xx 10 cm tubes and y 5 cm tubes	Time, position, and depth refer to point of bottom contact by the gear (and are based on gear-mounted USBL beacon data when available)
MSC	Marine snow catcher	
NBST	WHOI neutrally buoyant drifting sediment trap	
OTSB14a	Semi-balloon otter trawl, 14 m head rope, (slight variant on standard pattern?)	Times, positions, and depths are estimates of trawl at the seabed
PAP1	ODAS buoy and instrument frame	
PAP3	Sediment trap array	
Pelagra	NOC neutrally buoyant drifting sediment trap	
RCF	"red camera frame", carries LISST-HOLO and P-cam	
SAPS-M	Stand alone pumping system; McLane type	
SAPS-O	Stand alone pumping system; OSIL type	
STT	WHOI surface tethered drifting sediment trap	
WP2	Zooplankton net	