

**INSTITUTE OF OCEANOGRAPHIC SCIENCES
DEACON LABORATORY**

INTERNAL DOCUMENT No. 334

VHF Data Telemetry

K G Birch, C H Clayson & R W Pascal

1994

Wormley
Godalming
Surrey GU8 5UB UK
Tel +44-(0)428 684141
Telex 858833 OCEANS G
Telefax +44-(0)428 683066

DOCUMENT DATA SHEET

<p><i>AUTHOR</i></p> <p style="text-align: center;">BIRCH, K G, CLAYSON, C H & PASCAL, R W</p>	<p><i>PUBLICATION DATE</i></p> <p style="text-align: center;">1994</p>
<p><i>TITLE</i></p> <p style="text-align: center;">VHF Data Telemetry.</p>	
<p><i>REFERENCE</i></p> <p style="text-align: center;">Institute of Oceanographic Sciences Deacon Laboratory, Internal Document, No. 334, 46pp. (Unpublished manuscript)</p>	
<p><i>ABSTRACT</i></p> <p>The objective of the VHF Data Telemetry system was the collection of continuous raw data from the Solent Sonic anemometer, whilst the sensor was deployed at sea, on the Sonic Buoy.</p> <p>The aims of the development project were achieved within short timescales and the successful sea trial proved the overall system operationally viable.</p> <p>The success of the system exceeded that expected, with 98% of data blocks received without errors. Analysis of the data success rates is shown, and areas for future development discussed.</p> <p>The system hardware and the techniques are detailed, also included are the operational notes for upgrading the transmitter EPROM and the closing of data files via the RF link.</p>	
<p><i>KEYWORDS</i></p> <p>DATA TELEMETRY SOLENT SONIC ANEMOMETER SWALES VHF</p>	
<p><i>ISSUING ORGANISATION</i></p> <p style="text-align: center;"> Institute of Oceanographic Sciences Deacon Laboratory Wormley, Godalming Surrey GU8 5UB. UK. </p> <p style="text-align: center;">Director: Colin Summerhayes DSc</p> <p style="text-align: right;"> <i>Telephone</i> Wormley (0428) 684141 <i>Telex</i> 858833 OCEANS G. <i>Facsimile</i> (0428) 683066 </p>	
<p style="text-align: center;"><i>Copies of this report are available from: The Library,</i></p>	
<p><i>PRICE</i></p> <p style="text-align: right;">£0.00</p>	

1.	OVERVIEW	7
2.	INTRODUCTION	7
3.	EXPERIMENT LOCATION	8
	3.1. Map of the Area	9
	3.2. Equipment & techniques	10
	3.3. System Diagram	12
4.	DATA SOURCES AND PROCESSING	13
	4.1. Data Quality Checking	14
	4.2. Summary of Data Produced	14
5.	CONCLUSIONS	22
6.	ACKNOWLEDGEMENTS	22
7.	APPENDIX A - THORCOM OPERATIONAL NOTES	23
	7.1. Introduction	23
	7.2. Buoy Equipment	23
	7.3. Shore Equipment	24
	7.4. Operation of system	25
8.	APPENDIX B - SOFTWARE TO CLOSE PC FILES VIA RF LINK	26
9.	APPENDIX C - REPLACEMENT OF TRANSMITTER EPROMS	28
10.	APPENDIX D - DATA FORMATS	30
	10.1. Appendix D.1 Raw Data Files	30
	10.2. Appendix D.2 FASTCOM Files	31
	10.3. Appendix D.3 Error Files	31
11.	APPENDIX E - RADIO LICENCE	33

12.	APPENDIX F - SHORE STATION SPECIFICATION	38
13.	APPENDIX G - SOFTWARE FLOW DIAGRAMS	40
13.1.	Appendix G.1 THORREAD.C	40
13.1.	Appendix G.2 THORSTAT.C	42
13.2.	Appendix G.3 THORSUMM.C	44
13.3.	Appendix G.4 REPLAY2.C	45
14.	APPENDIX H - USEFUL ADDRESSES	46

1. OVERVIEW

The objective of the Telemetry Data system was the collection of continuous raw data from the Solent Sonic anemometer, whilst the sensor was deployed at sea, on the Sonic Buoy.

The transmitter operations are transparent to the other buoy sub-systems, requiring only the power from the primary battery packs. Once a second serial data blocks with, on average, 20.83 sets of measurements are encoded by a radio modem and transmitted via an omnidirectional aerial to a shore receiver. The decoded data are error checked and written to time stamped data files on a dedicated personal computer (PC).

Off line processing, checks each file for short records and gaps in the data. The data files are re-formatted to the standard Sonic data file format, by the removal of the 'block counter' and block length words, with header information derived from the file time stamp.

The success of the system exceeded that expected, with 98% of data blocks received without errors. Analysis of the data success rates is shown, and areas for future development discussed.

The report details the data collected, together with file formats. Software developed for file format conversion and error analysis of the data is included.

Arrangements for the shore station erected for SWALES, for the first operational trial are detailed. Also included is a copy of the 'temporary use' radio licence obtained from Department of Trade and Industry Radiocommunications Agency

2. INTRODUCTION

The development of the Sonic Buoy has provided the opportunity for spectral wind data measurements without the air flow distortion associated with a ship's superstructure. However the change in the sensor platform from a ship to a buoy requires consideration of the effect of the waves on the air flow and the energy introduced by the motion of the buoy.

To quantify possible platform effects, the collection of raw data was considered necessary over a range of wind and sea conditions. But as the data rate of the Sonic anemometer is ~750K Bytes per hour, onboard data storage was not considered viable. The solution adopted was to transmit the data in real time to an on shore recording system.

The Sonic Buoy has a 3m diameter discus surface following hull with a 2.5m high tower on which the sonic anemometer is mounted. The buoy is orientated into the wind by a 'V' shaped vane with the anemometer mounted on the buoy's windward leading edge. This deployment technique places the anemometer sensor head within ~3m of the sea surface.

3. EXPERIMENT LOCATION

The mooring site for the Sonic Buoy was $51^{\circ} 29.5' N$ and $4^{\circ} 45.0' W$, with the receiving Land Station at Hill Farm, Manorbier, Nr Tenby, $51^{\circ} 47.0' N$ and $4^{\circ} 47.0' W$.

The buoy was moored about eight miles due south from the receiving station, in direct line of sight. The Hill Farm site was selected because of its elevation above mean sea level (~70 metres), and proximity to the coastline, maximising available signal strength. The receiving aerial was in a field adjacent to a radar tracking station, however there was no evidence to suggest any interference or signal loss attributable to the proximity between the two systems.

The receiving aerial was mounted on the top of a telescopic mast, which was 11 metres above ground level when fully extended. To improve the durability in strong winds the mast base was deployed just below the crest of the hillside. Three guy ropes from the mast top were fixed to the ground at 120° spacing to increase stability and a single guy was used to maintain the aerial in the correct orientation with respect to the buoy. As the aerial array was offset from the mast, a counter balance weight was included to maintain the load distribution.

The mast endured the buoy deployment period without mishap. However some difficulty was experienced as water leaked into the mast hydraulics, which made lowering and raising difficult, especially in cold conditions.

The shore station shed was erected specifically for the SWALES project. Mains power was connected, by external contractor, from the adjacent farm buildings, with both power and lighting circuits. The internal fitting out of the shed with benches and equipment was carried out by IOS staff

The aerial was located about 80 metres due south of the shore station, across a field, with the cable connecting the aerial to the receiver routed along the field fencing, and attached by cable ties. At the point where the cable crossed a gateway, a rubber cable protector was utilised to prevent possible damage being caused by vehicles pressing the cable against the sharp flints within the soil.

Details of the shore station building and electrical specification at Hill Farm, Manorbier are in Appendix F

3.1. Map of the Area

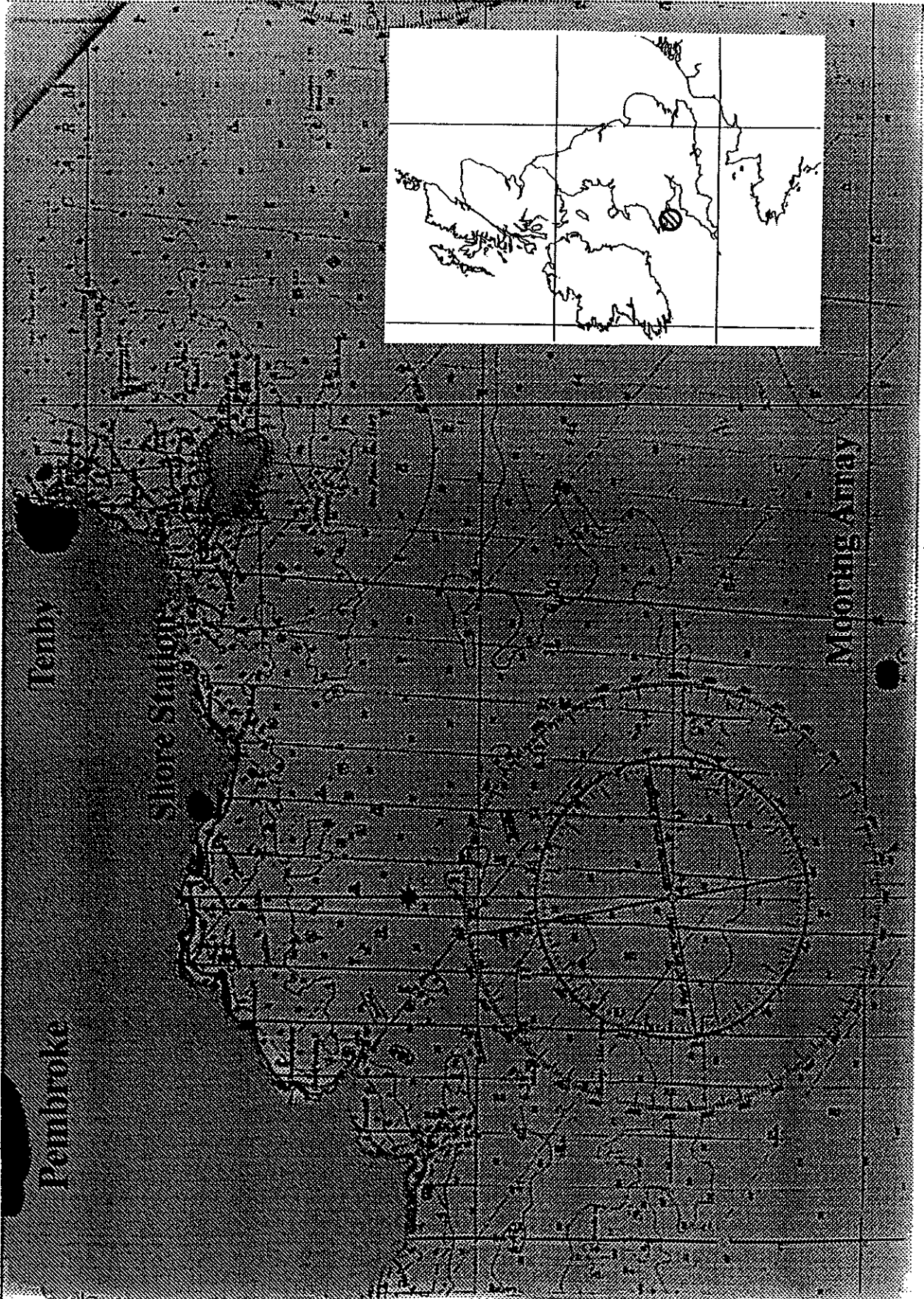

3.2. Equipment & techniques

The transmitter, an RCL220, was enclosed in a die cast case, rated to IP65, with the antenna connected to the unit via BNC connector. Both the transmitter power and anemometer data signals were connected via a 19 Way MIL 62GB connector.

Operating at 153.300 MHz, the transmitter generated 0.5 Watt RF transmitted power to a 3db co-linear omni-directional whip aerial. It was powered by a 12V supply derived in the buoy raw data logger module.

The 'turnkey' receiving system was configured in a 19 inch housing and could operate without a screen or keyboard. The logging computer hardware was a 386 STE BUS personal computer (PC), configured with a 500 Mbyte IDE hard disc and 3.5 inch floppy disc drive. For the SWALES Experiment the unit was mounted into a wooden travelling case together with a Tandon monitor and keyboard. The availability of the screen proved important, as it allowed visual monitoring of the data received at the shore station, which enabled early detection of the short record events within the transmitted data blocks.

The receiver within the system was a standard RNC400 which checked, under firmware, for errors within the received data blocks. If the receiver detected an error between the transmitted and received checksums, then the whole data block ,i.e. one seconds' data, was rejected. 'Good' data blocks were passed to the PC, which formatted the data and stored the files onto the hard disc.

During the testing of the system, upgrades were made to the buoy transmitter firmware, which required the changing of the EPROM within the RCL220 unit. To save time these upgrades were carried out by IOS staff under a set of notes guidance and a diagram ,which was generated by Thorcom . These notes are included in Appendix C

Because of the high volume of data being recorded, frequent backup of the hard disc was necessary. This was usually on a weekly basis, using a tape streamer connected via the LPT1 printer port. However this was not entirely satisfactory as problems occurred both when recording and replaying the data. The exact cause was not determined, but appeared to be a function of the tape temperature during either operation. An alternative solution was considered using an optical disc drive, but this did not prove feasible within the timescale of the experiment.

When the buoy capsized on Day 317, terminating the first deployment period, the data file on the shore station was left open. As this contained the last seconds of the buoy motion data, this file was important to recover. The recording software within the PC logger examined the keyboard buffer after each data block was written to file, and then returned to waiting for new data. As there was no data input the keyboard buffer was not being read and hence it was not possible to close the file under manual control via the keyboard.

The solution adopted was to force the closure of the file by the generation of RF transmitted data block. The implementation used the transmitter sub-system from the buoy together with a simulated anemometer data message generated by a portable PC. The program was written

by Thorcom and amended at IOS to suit the Husky portable PC. The details of the program used are in Appendix B

The operation of the Sonic anemometer, on buoy, is under the control of the Sonic processor, which configures the baud rate, sets the mode of operation, and polls the sensor for data when in the prompted mode. At the start of each quarter hour the Sonic processor re-configures the anemometer from 'unprompted' mode into 'prompted' mode with the control characters "PP". At the completion of collecting 12 * 1024 data samples the characters "UU" are used to reset the anemometer into the 'unprompted' mode.

To allow the shore station PC to correlate the recorded raw data with the buoy processed data these "PP" and "UU" characters were transmitted in between the anemometer data blocks. As the radio modem has only one serial input both of the data lines between the anemometer and the Sonic processor are diode 'OR' gated together. After 'power on' of the transmitter and the anemometer, firmware within the modem detects the transition between modes. Transmission from the buoy commences immediately these criteria, i.e. 'PP' or 'UU', have been reached. The mode switch commands are used by the receiving station to synchronise datasets with the buoy. Each occurrence of a mode change initiates the opening a new file. The duty cycle between prompted and unprompted data is approximately 2:1.

At the Shore receiving station a 6 element VHF yagi directional aerial with 8.5db gain was mounted with clear line of sight to the buoy. A high gain mast head amplifier, which was powered from the receiving station via the co-ax cable, enabled the receiver/recording system to be mounted away from the aerial position.

Within the receiving station the signal is decoded by the customised receiver and recorded to hard disc. The logging PC opens a new data file when transmitted data contains the control characters "PP" or "UU". Each file is named with the time that the file is opened suffixed by ".PDT" prompted or ".UDT" unprompted.

To operate the system, within the Radiocommunications Act, it was necessary to obtain the necessary licence. Recently introduced by the Radiocommunications Agency is a 'temporary use' licence, which is designed to be flexible, and can allow allocation within bands not normally permissible. Our licence was granted within fourteen days of submission of the form RA225 together the payment of fixed fee. A copy of the radio licence are in Appendix E

The system configuration as used in the buoy is shown in the diagram on the next page.

Base/Shore Station Receive Only Equipment

Buoy Transmitter

3.3. System Diagram

6 element Yagi
8.5dB gain
eg. Jaybeam 7042

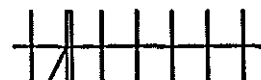

Pre-amp

Mast-head mounted
RF pre-amplifier

RG213 co-ax feeder

ANTENNA
3dB co-linear
eg. Jaybeam 7074



RF17
153MHz
500mW

RLC220
Radio
Modem

RS232 Data Messages

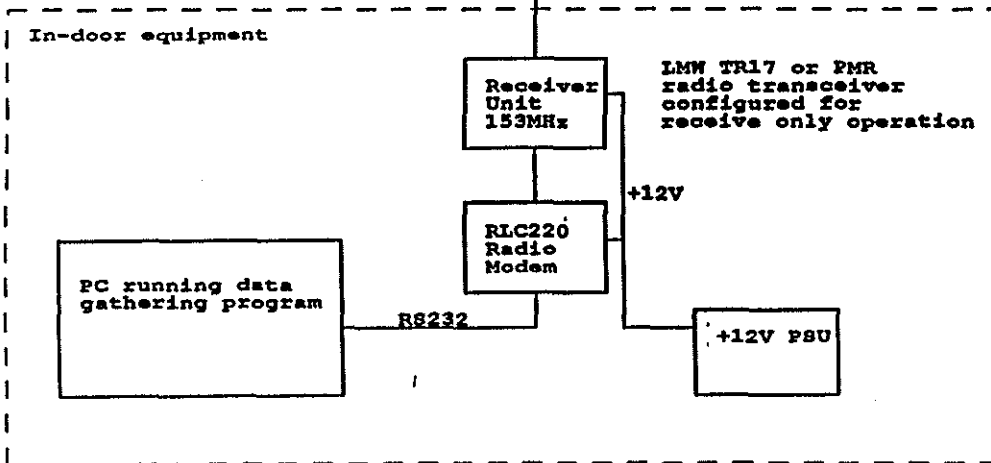

Thorcom Systems Limited
Unit 4,
96B Blackpole Trading Estate West,
Worcester, WR5 1PW, England, U.K.
Tel: 0905 756700 Fax: 0905 755777

Title		
Institute of Oceanographic Sciences		
Size	Document Number	REV
A4	Data logger link	1
Date:	July 23, 1993	Sheet 1 of 1

4. DATA SOURCES AND PROCESSING

The application THORREAD.EXE was developed to convert .PDT and .UDT files produced by the THORCOM system into files of the standard binary FASTCOM format produced by the shipboard logging systems. If an error is encountered in the data, it deals with it in the manner described in the header of the source file listing THORREAD.C (see Appendix G.1). It also produces an ASCII error file, suffix .PDE or .UDE, listing the missing and bad blocks in the input file.

The program can be used under batch files TXPDR.BAT and TXUDR.BAT, suitably modified, to process a number of files with an appropriate wild card selection:

TXPDR.BAT

```
for %%f in (logdata\*.pdt) do thorread %%f
rem translates Tubby format to FASTCOM format and generates error files
rem alter pathfile (in brackets) to use wildcards, etc., as required
```

TXUDR.BAT

```
for %%f in (logdata\*.udt) do thorread %%f
rem translates Tubby format to FASTCOM format and generates error files
rem alter pathfile (in brackets) to use wildcards, etc., as required
```

Since the quantity of data collected is large and the requirements for using it are, as yet, undefined, the transfer to FASTCOM format files has only been carried out on a small number of files, for test purposes. However, there was an immediate interest in the reliability of the system, so the application THORSTAT.EXE was produced. This is a cut down version of THORREAD which has been used to analyse the .PDT and .UDT files for errors, producing an ASCII error file for each file processed.

Since a very large number of error files were produced, the application THORSUMM.EXE was developed to combine the errors listed in the error files produced by the above two applications into a tabular ASCII error statistics file.

The program can be used under batch files SUMPDE.BAT and SUMUDE.BAT, suitably modified, to process a number of files with an appropriate wild card selection:

SUMPDE.BAT

```
for %%f in (c:\data\*.pde) do thorsumm %%f
rem produces summary file of errors
rem alter pathfile (in brackets) to use wildcards, etc., as required
```

SUMUDE.BAT

```
for %%f in (c:\data\*.ude) do thorsumm %%f
rem produces a summary file of errors
rem alter pathfile (in brackets) to use wildcards, etc., as required
```

For test purposes and for eventual spectral processing, the application REPLAY2.EXE was produced; this is a form of the shipboard processing application FFTSETSW, used on "Warden". It is used to re-process a FASTCOM format file produced by THORREAD but, where bad data is encountered (as shown by a zero velocity of sound value), it substitutes the previous section's data accumulator values and flags the section of 1024 points of data so that it is not used.

The program can be used under batch files REPPDR.BAT and RERUDR.BAT, suitably modified, to process a number of files with an appropriate wild card selection:

REPPDR.BAT

```
for %%f in (c:\data\*.pdr) do replay2 12 %%f
rem displays time series graphically and does spectral processing as per FFTSETSW
rem alter path\file (in brackets) to use wildcards, etc., as required
```

REPUDR.BAT

```
for %%f in (c:\data\*.udr) do replay2 6 %%f
rem displays time series graphically and does spectral processing as per FFTSETSW
rem alter path\file (in brackets) to use wildcards, etc., as required
```

4.1. Data Quality Checking

Quality checking and a limited amount of error correction are carried out during the translation process, as described above. The net result of missing blocks of raw data is that the spectral analysis is performed on a lesser number of (1024 sample) sections, resulting in an increase in the confidence limits for the spectral estimates. Other schemes of processing could be implemented, such as the use of different length sections and the discarding of only the missing blocks, rather than the complete sections.

4.2. Summary of Data Produced

4.2.1. Raw Data Files

The complete list of data files collected during SWALES are available in the SWALES Sonic Buoy - telemetry data report, IOS No 332 .

The format of the data files, which are written to disc in DOS format, is described in Appendix D.

To measure the success of the dataset obtained during SWALES, all the files have been analysed for errors by THORSTAT and THORSUM. The analysis has been performed in four sections corresponding to 'prompted' & 'unprompted' modes for the periods day 279-313 and day 327-338. Within the dataset there were two specific criteria for the detection of an error :-

i) A 'short record' where the message is transmitted and received correctly, but during the encoding the message has been truncated before the entire data frame has been encoded and transmitted. From inspecting the data it is usually found to only affect the last byte which is the compass word. As this word updated at a slower sampling rate (4 times a second) than the anemometer sampling frequency the word is repeated within the dataset and therefore these errors can be corrected.

ii) A 'missing record' occurs, when data received & transmitted check sums were not in agreement. The data frame was rejected by the receiver and no data recorded by the logger. As there was no information available from the receiver it was impossible to determine the extent of corruption within any of the data blocks.

The analysis shows that the overall success in 'good' data being received was 98%, which exceeded the predicted target of 95%

There was a noticeable improvement in the success rate of received data during the second deployment. However account must also be taken of the environmental conditions, which were considerable worse for the second deployment. Therefore it can be argued that if the errors are associated with poor environmental conditions, then the improvement maybe more significant that the figures suggest.

However there was no obvious dependence in the success rate attributable to the operational mode of the anemometer, i.e. 'prompted' or 'unprompted'.

An attempt was made to correlate the data 'errors' against the wave data, as measured by Datawell directional waverider, which was moored about 200m from the Sonic buoy. The coincidence of errors was plotted against wave height and the against wave slope.

Neither are conclusive, but there appears to be better correlation with wave slope rather than wave height.

DEPLOYMENT 1 - PROMPTED DATA - TOTAL NUMBER OF BLOCKS = 1118426

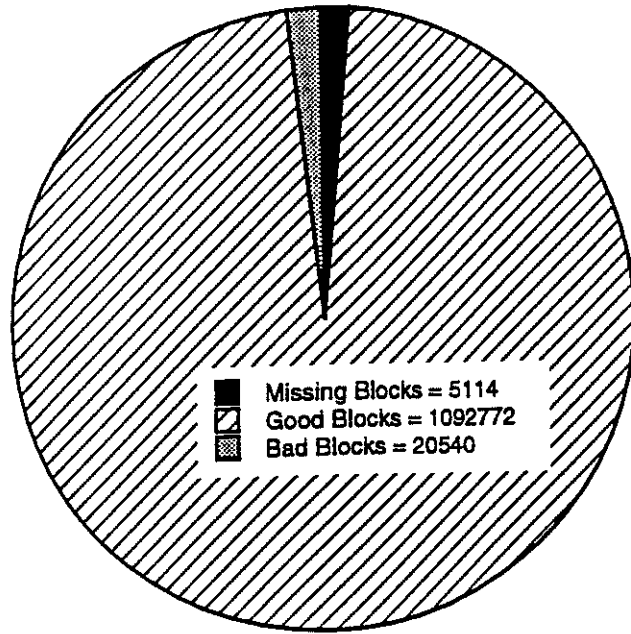

DEPLOYMENT 1 - MISSING BLOCKS (SMOOTHED) FROM PROMPTED DATA

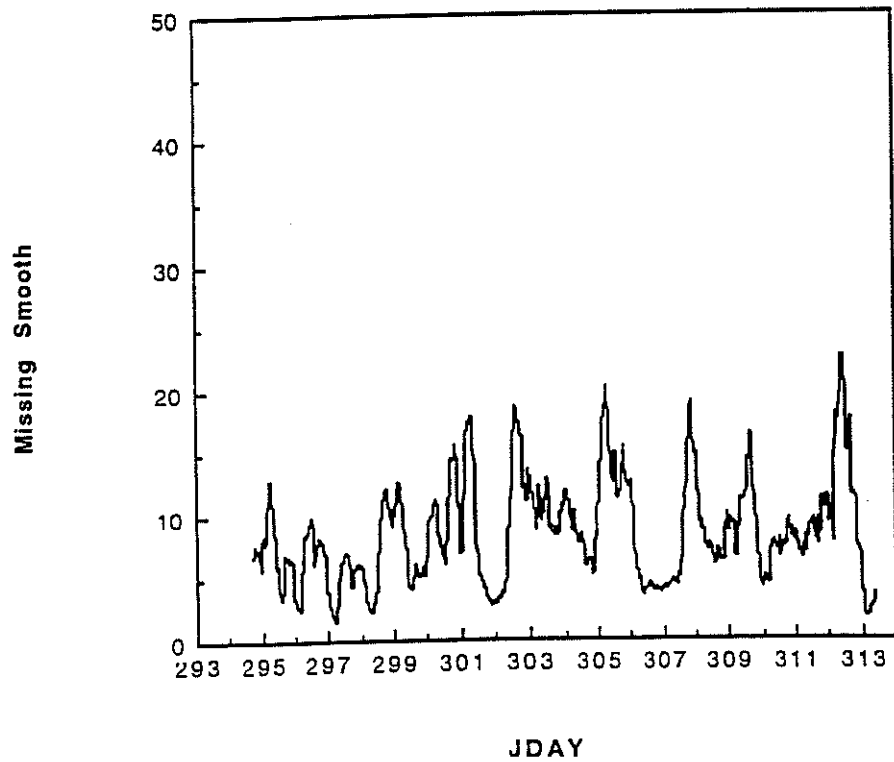
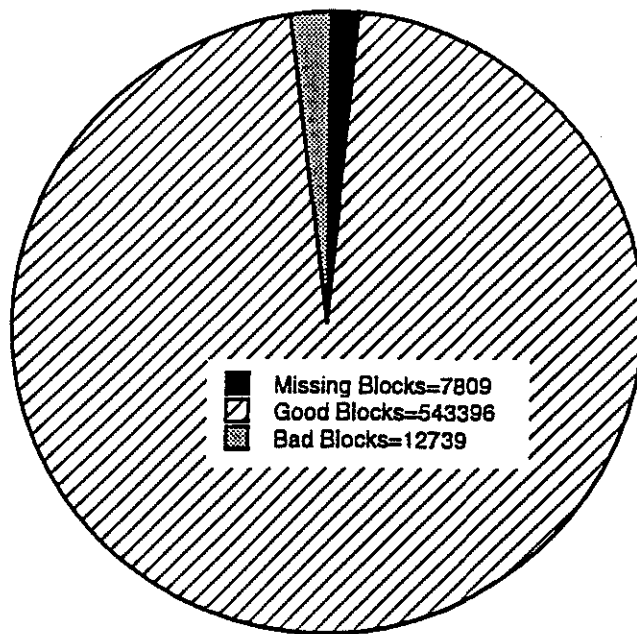

Fig 1. Prompted data - day 294 to 313

DEPLOYMENT 1 - UNPROMPTED DATA - TOTAL NUMBER OF BLOCKS = 555466



DEPLOYMENT 1 - MISSING BLOCKS (SMOOTHED) FROM UNPROMPTED DATA

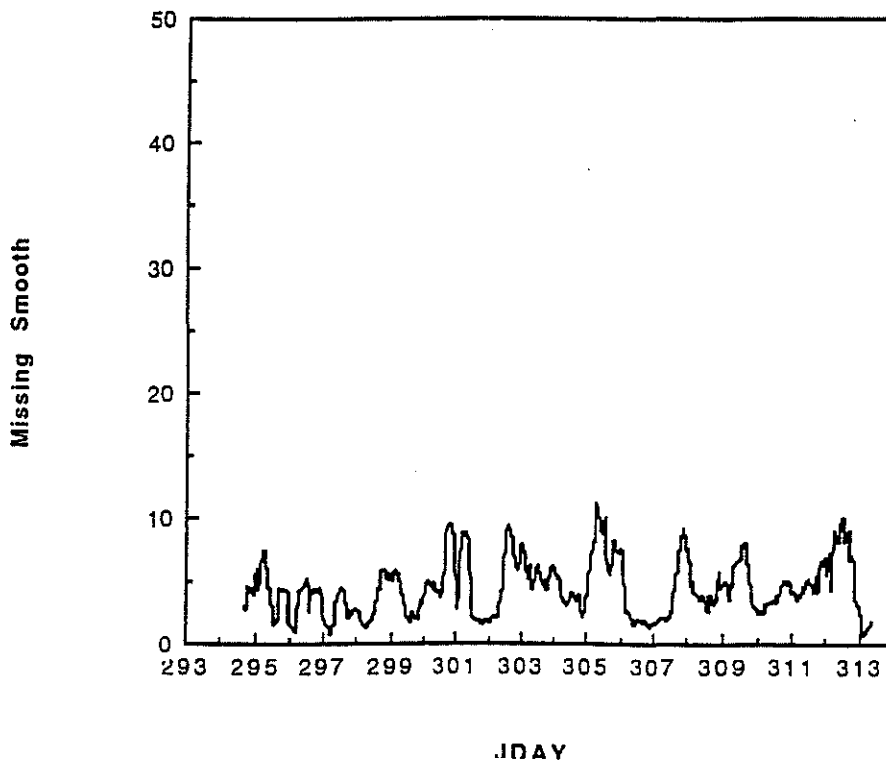
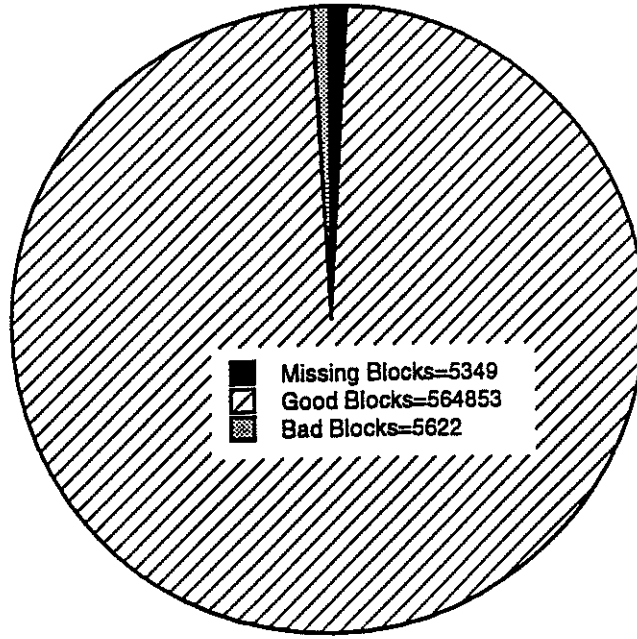

Fig 2. Un -prompted data - day 294 to 313

DEPLOYMENT 2 - PROMPTED DATA - TOTAL NUMBER OF BLOCKS = 575824



DEPLOYMENT 2 - MISSING BLOCKS (SMOOTHED) FROM PROMPTED DATA

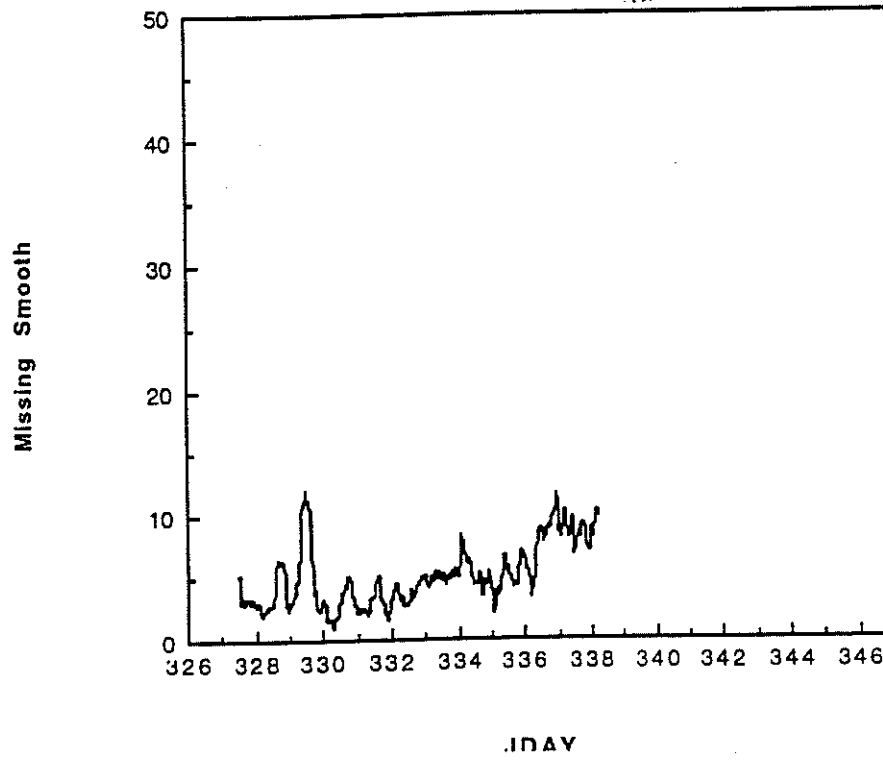
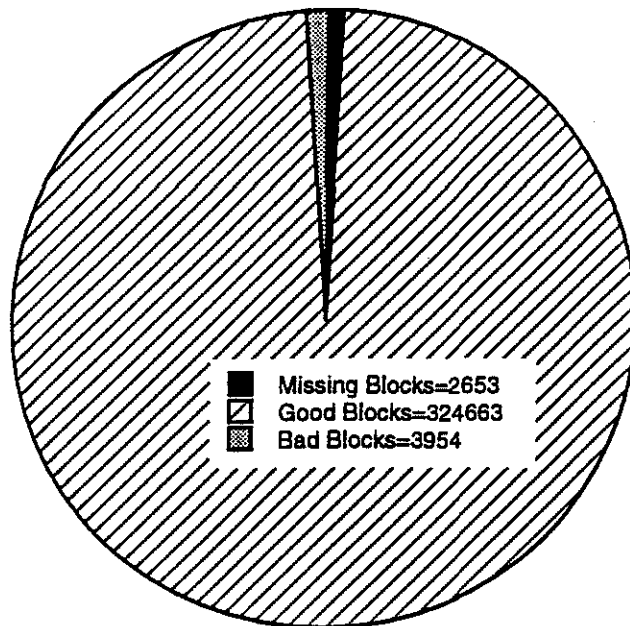

Fig 3. Prompted data - day 327 to 338

DEPLOYMENT 2 - UNPROMPTED DATA - TOTAL NUMBER OF BLOCKS = 331270



DEPLOYMENT 2 - MISSING BLOCKS (SMOOTHED) FROM UNPROMPTED DATA

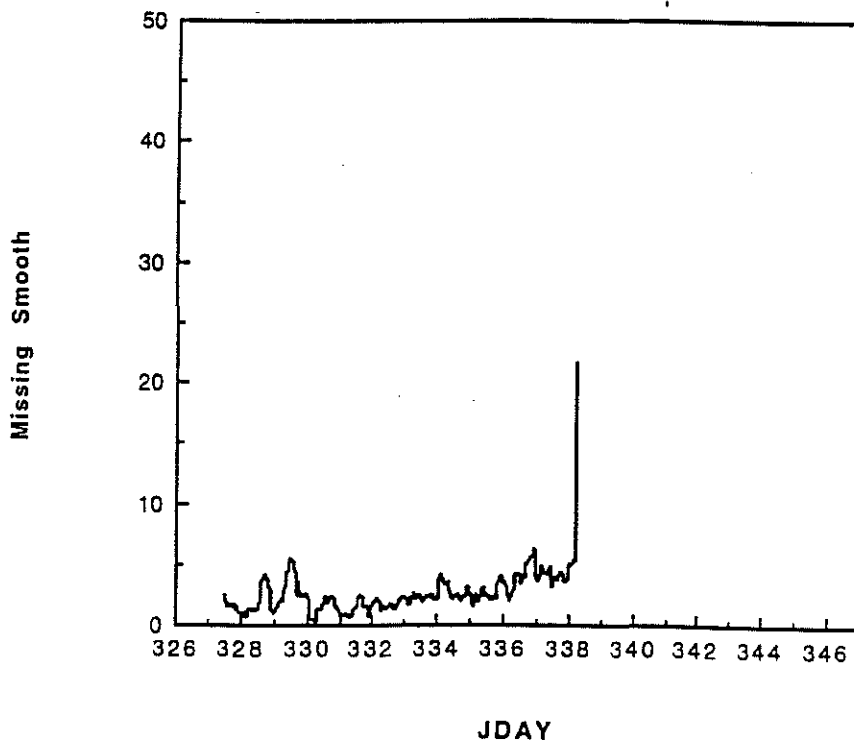

Fig 4. Un - prompted data - day 327 to 338

SWALES Telemetry Errors vs Wave Height

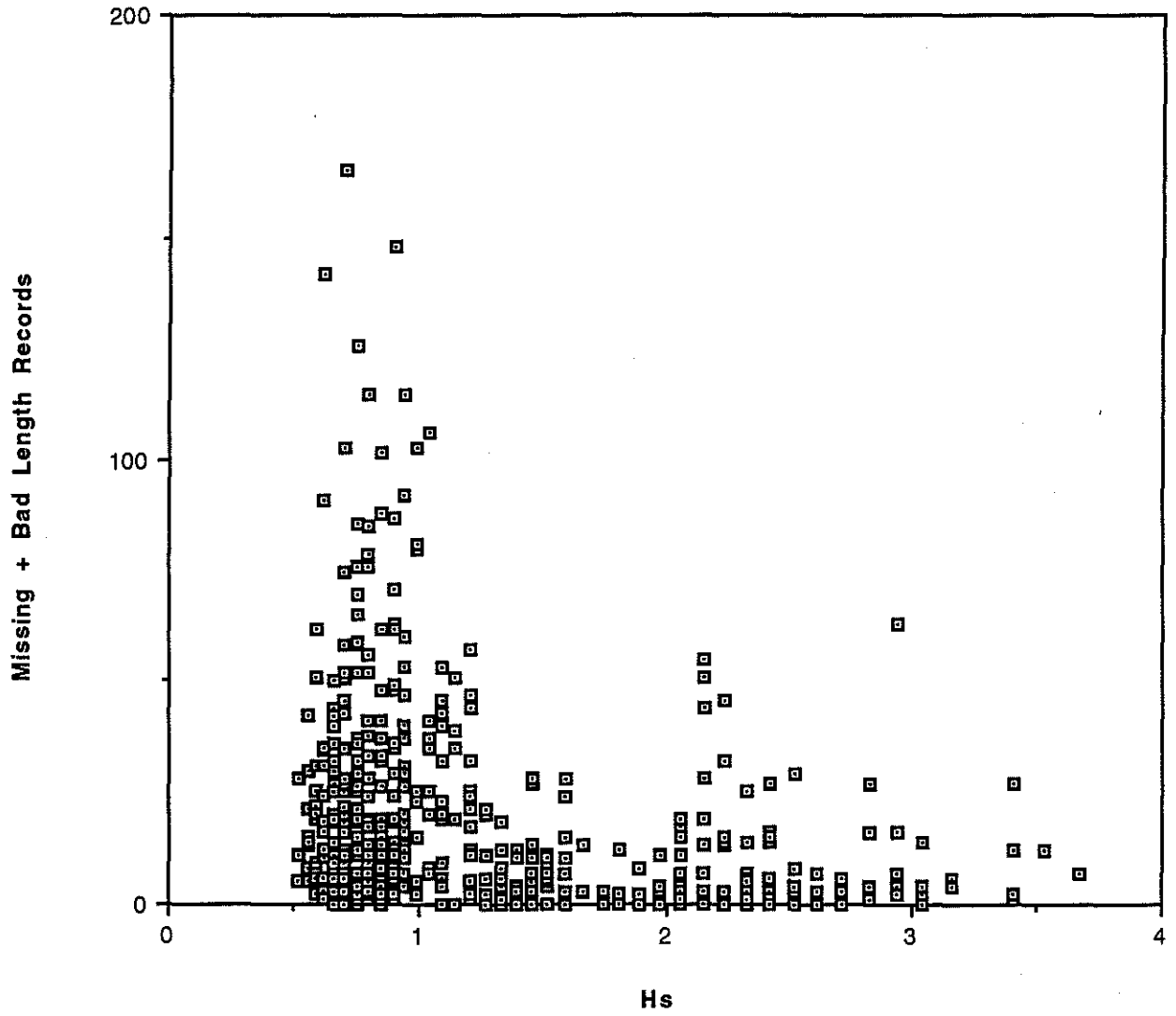

Fig 5. SWALES Errors vs Wave Height

SWALES Telemetry Errors vs Wave Steepness

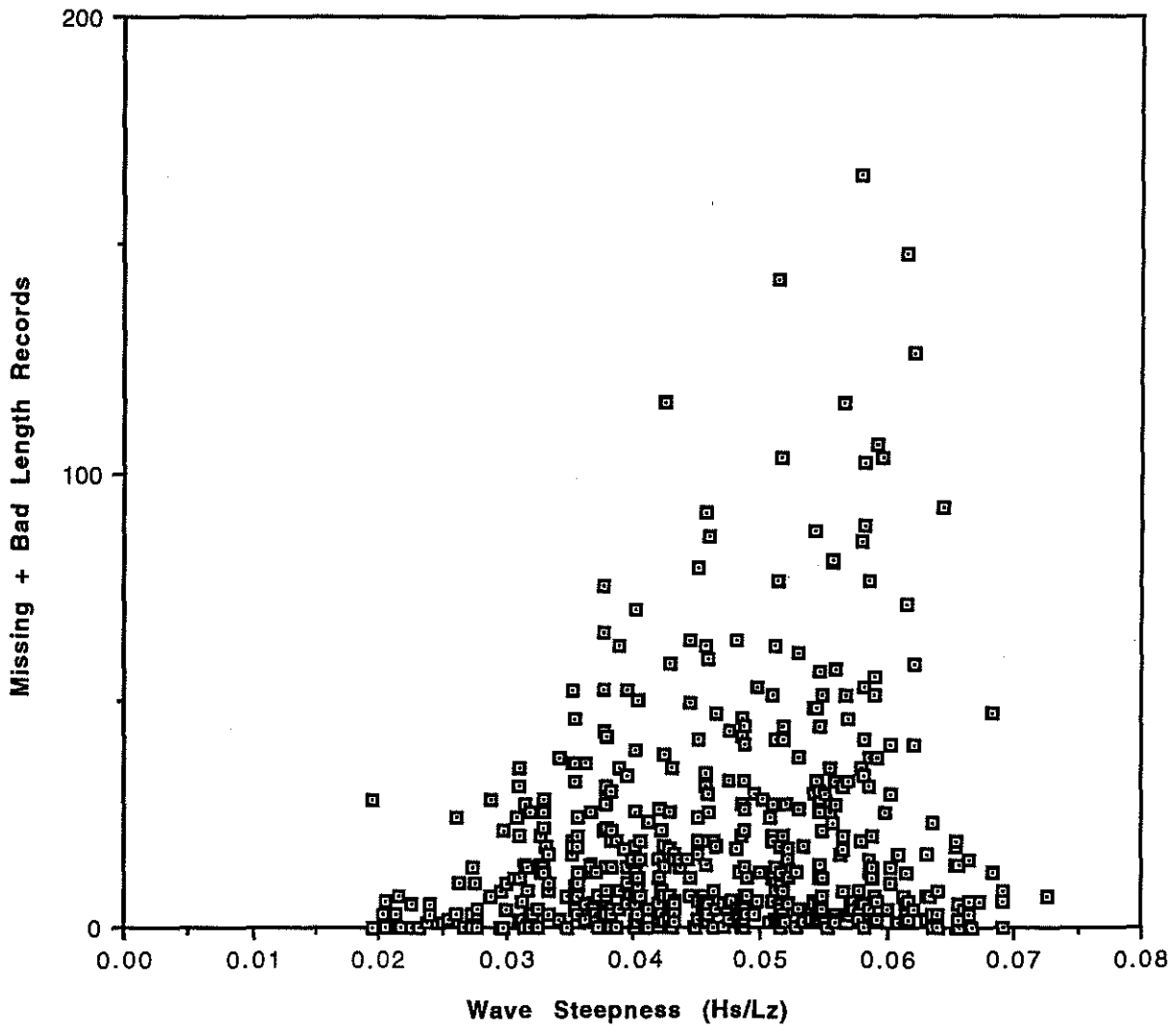

Fig 6. SWALES Errors vs Wave Steepness

5. CONCLUSIONS

The aims of the development project were achieved and the successful sea trial proved the overall system operationally viable.

By completion of this development within short timescales it has shown how external expertise can be used to supplement our own skills base, but has also highlighted how care must be taken in the project planning and specification.

After further consideration of the techniques used in the data transmission system, it is perceived that there are solutions which may increase the transmission success rate. Amongst the possible solutions are :-

i) transmitting each data frame twice, however this will double the power budget.

Doubling the data rate is now possible under new licencing restrictions, however when the system was designed the overall data throughput was near the maximum permissible 2400 baud rate.

ii) implementation of forward error correction.

By introduction of extra transmitted information, which could be used to correct transmission errors, for example by encoding eight bit data as eleven bits, an error rate of two bits could be tolerated.

iii) sending data in smaller frames i.e. more than once a second.

This would prevent a complete one second dataset being rejected every time an error was detected.

6. ACKNOWLEDGEMENTS

Without the advice and technical support of Thorcom this development would not have reached fruition, with particular thanks to Mike Tubby who directed the design of the system within Thorcom

Our thanks must also be extended to Mr Morgan at Hill Farm Manorbier for allowing the erection of our shore station and aerial mast on his farmland.

The SWALES data set was the result of the concerted efforts of many, including the IOSDL Centre for Ocean Technology Development members of the Met Team, the IOSDL Moorings Team and the JRC members of the Met Team. The experimental work was funded by the MAFF Flood and Coastal Defence Division under commission FD0603; analysis of the data will be under commission FD0601.

7. APPENDIX A - THORCOM OPERATIONAL NOTES

Data Link & Logging System for Sonic Anemometer

7.1. Introduction

This document describes the installation and use of the data link and data logging software system provided for the Institute of Oceanographic Sciences (Deacon Lab).

The system comprises a radio modem and transmitter module for use with the Sonic Anemometer system on the buoy, and a shore based receiver and PC compatible system in a single desk top case with data logging software as a "turn key" solution.

7.2. Buoy Equipment

The buoy equipment consists of a 0.5 watt transmitter operating on 153.300Mz and an RLC220 radio modem which has been programmed to accept messages from the Anemometer and control system.

The radio transmitter and modem are housed in an IP65 die-cast case. The following connections are provided:

1. BNC antenna connector. This is a 50 Ohm BNC socket for connection to a suitable co-axial cable and 50 Ohm antenna.

DO NOT OPERATE THE TRANSMITTER MODULE WITH OUT AN ANTENNA (OR SUITABLE "DUMMY LOAD") CONNECTED.

2. 5.3. pin MIL 62GB series connector. This supplies power and data to the transmitter module, pin out is as follows:

- A Ground connection (Black)
- B +12V Power connection (Red)
- C Ground connection (Black)
- D RS232 data input no. 1 (Grey)
- E RS232 data input no. 2 (Grey)

All other pins are not connected.

Both ground pins are connected together, two wires are provided so that both the power supply and RS232 ground can be wired up.

The two RS232 channels are interchangeable, they are "diode or-ed" together inside the unit. Connect one RS232 channel to the Anemometer and one to the control system.

7.3. Shore Equipment

The RNC400 is provided as a "turn key" solution in the literal sense, the RNC400 has an On/Off key switch. The software is already loaded and configured, the system should start up when the unit is switched on.

RNC400 has the following connections:

1. Mains input. This is a standard IEC mains inlet. Power requirements are: 190-260V AC, 50-60Hz, 120VA. The unit can be converted for operation from 110VAC by installation of a replacement power supply if necessary.
2. Antenna. For the connection of the receiving antenna & pre-amplifier unit.
NB. The antenna socket carries the +12V supply to the pre-amplifier and should not be short circuited.
3. Slave TRX. This connector is not used in this application, leave un-connected.
4. COM 1 & COM2 connectors. The RNC400 has non-standard use of the COM 1: and COM2: sockets on the rear panel. Please note carefully:
COM1: socket is ACTUALLY the LPT1: connector (i.e.. parallel printer port)
COM2: is not connected.

this comes about because the rear panel is a standard item and the system built for IOSDL uses a different (more powerful) processor than the normal RNC400 system. The normal RNC400 has two external serial ports and no printer port.

The serial (RS232) ports are available internally but are not used in this application.

5. VDU, this is a 15-way high density D-type connector for connection to a VGA mono/colour monitor.
6. Keyboard, this is a 5 pin DIN socket for connection of standard PC/AT type keyboard.

7.4. Operation of system

The buoy equipment will transmit Anemometer readings once it has received the first "PP" or "UU" command from the control system and the first full reading message.

Until a "PP" or "UU" message is received the system remains idle.

Transmissions are on a reading by reading basis.

The receiving unit will take each reading and record it to a file whose name is created as per option A of our letter of 16 th August.

The RNC400 can be operated with or without a keyboard or monitor/display.

If a display is used the system will update the screen each time a reading is received and logged to disk. The message displayed includes the current file name, anemometer record/block number and number of bytes written to disk.

When the system is running, to exit from the program type Control-C, the program will then exit the next time it receives a message and prints on the screen.

Each time the buoy switches between prompted and un-prompted mode the current file is closed and a new file opened.

An error message will be displayed if the program cannot open a new log file. The only reason this should occur is if the disk becomes full

RNC400 has the following MS-DOS directories installed:

VDOS MS-DOS V6.0 operating system (disks and manual enclosed)

\SOURCE Program source code and executable for logging program, serial & radio port driver etc.

\LOGDATA The directory into which the main program puts log files

8. APPENDIX B - SOFTWARE TO CLOSE PC FILES VIA RF LINK

FAX from Thorcom, which enables the open data file containing last data transmitted from the Sonic anemometer to be closed on the Shore Station logger.

To: Keith Birch IOS Deacon Lab

From: Mike Tubby, Thorcom

Date: November 12th 1993

Subject: Un- jamming the RNC400 data logger

Keith,

If you run the following program on a lap-top PC it will send Anemometer-type frames to your transmitter module (orange box).

This in turn will send frames on the radio channel and allow you to use the ESCAPE key to exit the logging program, leaving all your stored data intact....

You will need a 19 pin 62GB series plug with +12V, Ground, and one of the RS232 data pins wired to the output of your lap-top computer .

The program runs under QUICK BASIC . Set the program running it will transmit approx 1 frame per second, then press ESCAPE on the main RNC400 keyboard.

```
10.  b$ = "*** IOS FORCE FILE: CLOSE * * * "
```

```
20.  cr$ = CHR$ (10) + CHR$ (13)
```

```
30.  b$ = b$ + cr$
```

```
40.  total = 1200
```

```
50.  FOR record = 1 TO 10000
```

```
60.  OPEN "com1:4800,N,8,1,BIN,RS" FOR OUTPUT AS 1
```

```
70.  a$ = "UU" + CHR$ (129) + CHR$ (129) + b$ + CHR$ (130) + CHR$ (130)
```

```
80.  PRINT #1, a$;
```

```
90.  FOR delay = 1 TO total: NEXT delay
```

```
100. PRINT # 1, "
```

```
110. CLOSE 1
```

```
120. NEXT record
```

NB. You need 30-40 spaces on line 100 of the program, exact number is un-important..

Good Luck!

As this was to be used in a portable application the software was amended to suit a Husky Hunter 16, PC compatible. The software alterations were to conform to the Husky's communications port protocol and the Liquid Crystal Display format of 6 lines * 40 characters long.

Program listing is as follows :-

```
1      RESET:CLS
5      ON ERROR GOTO 100
10     OPEN 'COM1:4800,N,8,1,DS0,CS" AS #1
15     PRINT "COMMS INITIATED"
20     B$ = "*** IOS FORCE FILE: CLOSE ***"
30     CR$=CHR$(10)+CHR$(13)
40     BS = B$ + CR$
50     TOTAL = 1200
60     FOR RECORD = 1 TO 10000
70     A$ = "UU" + CHR$(129) + CHR$(129) + B$ + CHR$(130) + CHR$(130)
80     PRINT #1, A$
85     FOR DELAY = 1 TO TOTAL: NEXT DELAY
90     PRINT # 1, "HELLO          "
100    NEXT RECORD
110    CLOSE # 1
```

9. APPENDIX C - REPLACEMENT OF TRANSMITTER EPROMS

To: Keith Birch / Institute of Oceanographic Sciences

From: Jonathan

Date: 16/9/93

Subject: Re: Replacement EPROM for buoy sender unit

With reference to the diagram on the following page :

Step 1 - Remove the Military connector by unscrewing the nut on the outside of the case.

Step 2 - Remove the securing screws for the PLC220 / transmitter assembly.

Step 3 - Remove the nut which secures the BNC socket connector. by pressing very firmly on the assembly as shown, and angling the chassis you should be able to remove it

Step 4 - Remove all connectors. The whole assembly should now be able to be removed.

Step 5 - RLC220 is sandwiched between 2 layers of aluminium with 4 mounting posts. Remove the nuts & star washers underneath the bottom plate - then the plate itself and the 4 small spacers

Step 6 - Unscrew the mounting post bolts sufficiently to free the RCL220 Board.

Step 7 - Replace EPROM

Note Reverse this procedure to re-assemble the transmitter sub-system

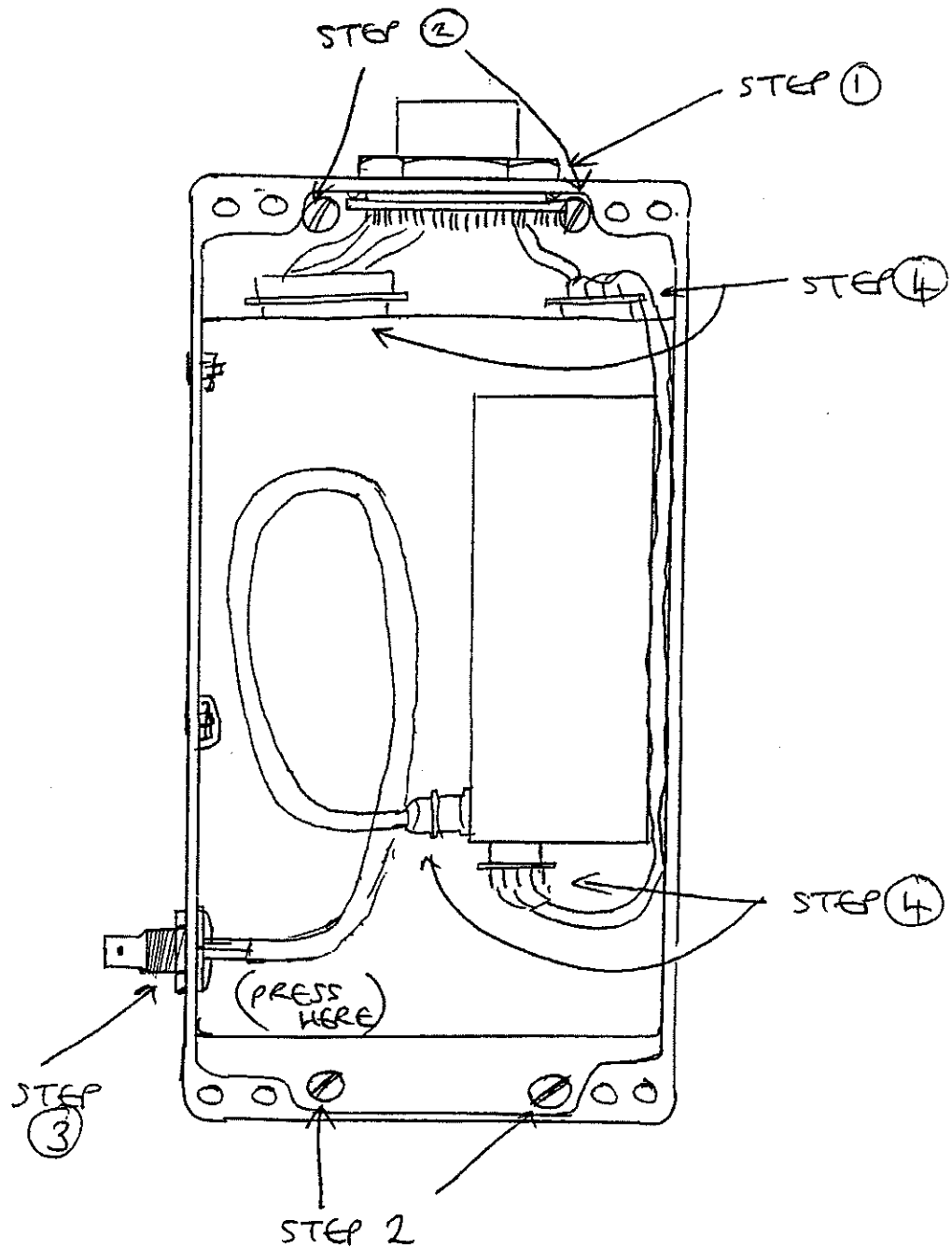

STEP ⑥ - UNSCREW THE MOUNTING-POST BOLTS
SUFFICIENTLY TO FREE THE RLC220 BOARD.

STEP ⑦ REPLACE EPROM:

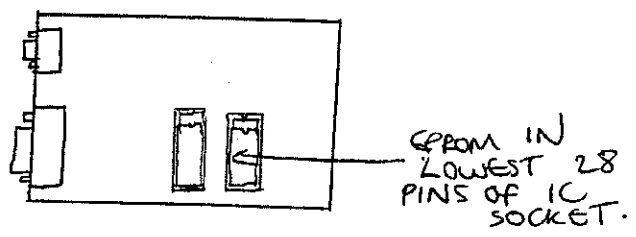

Fig 7. Diagram of Transmitter assembly

10. APPENDIX D - DATA FORMATS

10.1. Appendix D.1 Raw Data Files

The THORCOM receiving station produces files with suffices .PDT (prompted raw Sonic data) and .UDT (unprompted raw Sonic data); these share the same format.

The filenames have the form:

MMddhhmm.PDT

MMddhhmm.UDT

where MM = month (range 01 to 12)

dd = day (range 01 to 31)

hh = hour (range 00 to 23)

mm = minute (range 00 to 59)

Typical file lengths are 129000 bytes for .PDT files (approximately 10 minutes of raw data) and 68000 bytes for .UDT bytes (approximately 5 minutes of raw data).

Each file consists of a number of blocks of received data, each preceded by a 1 byte block length, range 0 to 255, normally 202, 212 or 222; the block length does not include this byte.

The block of received data consists of

Sonic record number (2 bytes, binary, range 0 to 65535)

a number (normally 20, 21 or 22) of Sonic samples, each consisting of the 10 bytes:

uuvvwwcchh

where U = uu

V = vv

W = ww are 3 velocity components each of 2 bytes (16 bit binary integers),

C = cc is a 2 byte velocity of sound (16 bit binary integer),

H = hh is a 2 byte compass reading (16 bit binary integer)

5.37.1. V and W normally have the range -6000 to +6000 for -60 m/s to +60 m/s, with a value of -10000 being used if there is a fault condition

C normally has the range 0 to +18500 for 0 m/s to 370 m/s, with a value of -10000 being used if there is a fault condition

H has the nominal range 2048 to 4088 for a compass output of 0 to 255 (0° to 358.6° clockwise relative to magnetic North)

10.2. Appendix D.2 FASTCOM Files

The standard FASTCOM file format consists of a header and a number of samples of data, i.e.

Header (44 bytes):

Mode<sp>l<LF>

Analog<sp>l<LF>

Time<sp>hh:mm:ss<sp>Date<sp>mm/dd/yy<LF>

a number of Sonic samples (about 12200 or 6400, depending upon whether the file was derived from a .PDT or a .UDT file, respectively), each consisting of the 10 bytes:

uuvvwwcchh

defined as in Appendix B.1, above.

10.3. Appendix D.3 Error Files

.PDE and .UDE files

The .PDE and .UDE files produced by either THORREAD or THORSTAT, are ASCII text files which begin with the line:

Start record no. sssss<LF>

- where sssss is the record number of the first block of data and <LF> is the line feed character (10).

In the event of errors being detected, this is followed by lines of the form:

Missing record at mmmmm<LF>

- where a non-sequential record number is detected, mmmmm being the expected record number.

and/or

Bad Block Length lll at rrrrr<LF>

- where lll is the block length minus 2 (the 2 record number bytes) and rrrrr is the record number.

Usually the block length is found to be one less than expected, i.e. 199, 209 or 219; this is not too serious, since it represents only the loss of the final compass reading. Bad length blocks are padded out to the nominal length with bytes of zero, the nominal length being defined as 210 for prompted data and 200 for unprompted data. Data with more than 2 bytes missing will be rejected by the application REPLAY2, since the padding will result in (one or more) zero velocity of sound values.

The length of a .PDE or .UDE file will, therefore, depend upon the number of errors encountered, with a good record resulting in a length of about 23 bytes and a defective record resulting in a length of at least 36 bytes.

SUMMARY.RDE and SUMMARY.NDE files

The SUMMARY.RDE and .NDE files produced by THORSUMM from .PDE and .UDE files, respectively, are ASCII tabular files which consist of a number of lines of the format:

```
ddd.ddddd<tab>missing<tab>bad<LF>
```

where ddd.ddddd is the (decimal) day number derived from the , e.g. 273.50694 for day 273 1210 hrs

missing is the number of missing blocks in the source file (.PDE or .UDE)

bad is the number of blocks with incorrect length (not a multiple of 20 bytes) in the source file (.PDE or .UDE)

<tab> is the tab character (9)

<LF> is the line feed character (10)

The day numbers will be in the order of processing and further use of the application THORSUMM will result in summary data being appended to the output files. The data can be sorted into sequential day number order by loading the table into CricketGraph and then using the Menu⇒DATA⇒SORT function.

11. APPENDIX E - RADIO LICENCE

Department of Trade and Industry Radiocommunications Agency
Wireless Telegraphy Act 1949 Section 1



LIC. NO. TMP/33

DEPARTMENT OF TRADE AND INDUSTRY

RADIOCOMMUNICATIONS AGENCY

Wireless Telegraphy Act 1949 Section 1

TEMPORARY USE LICENCE

UNITED KINGDOM OF GREAT BRITAIN AND NORTHERN IRELAND,
THE CHANNEL ISLANDS AND THE ISLE OF MAN

ESTABLISHMENT

1 This Licence ("the Licence") granted under section 1(1) of the Wireless Telegraphy Act 1949 ("the 1949 Act") on 23 August 1993 ("the Date of Issue") by the Secretary of State for Trade and Industry ("the Secretary of State") to the Institute Of Oceanographic Sciences ("the Licensee") [whose company number is] authorises the Licensee as from 1 October 1993 ("the Commencement Date") to establish and use the stations at the locations set out in the Schedule to this Licence ("the Schedule") for wireless telegraphy; FOR THE PURPOSES SPECIFIED IN AND SUBJECT TO THE TERMS, PROVISIONS AND LIMITATIONS CONTAINED IN THIS LICENCE.

PURPOSE OF USE

2 The Licensee may establish and use sending and receiving stations for wireless telegraphy at the locations specified in the Schedule for the purposes specified hereinafter:

TERMS, PROVISIONS AND LIMITATIONS

LIMITATIONS ON USE

3 The Licensee shall operate the Stations in accordance with the requirements set out in the Schedule.

APPARATUS

4 the Licensee shall ensure that the apparatus comprised in the Stations ("the Apparatus") is so designed, constructed, maintained and used that it does not cause any undue interference with any wireless telegraphy apparatus or stations for wireless telegraphy.

USERS OF THE STATIONS

5 The Licensee shall not permit or suffer any person to use the Stations unless that person is:

- (a) under the control of the Licensee, or

Department of Trade and Industry Radiocommunications Agency
Wireless Telegraphy Act 1949 Section 1



(b) authorised by the Licensee in writing to use the Stations.

6 The Licensee shall ensure that:

- (a) all persons authorised under Clause 5 above are made aware of the terms, provisions and limitations of this Licence; and
- (b) all such persons comply with the terms, provisions and limitations of this Licence.

CALL SIGN

7 During transmission, the Licensee shall transmit the call sign (if any) specified in the Schedule:-

- (a) at the beginning and at the end of each period of transmission and when the period of transmission is longer than 15 minutes, at the end of each interval of 15 minutes;
- (b) at the beginning of transmission on a new frequency (whenever the frequency of transmission is changed);
- (c) in the same format that is being used for the transmission of the information; and
- (d) on the same carrier frequency that is being used for the transmission.

NOTICE OF VARIATION OR REVOCATION

8 Where the Secretary of State exercises his power to revoke or vary this licence in accordance with section 1(4) of the 1949 Act, a written notice will be served on the Licensee.

INSPECTION

9 The Licensee shall permit a person authorised by the Secretary of State to:

- (a) have access to the Stations;
- (b) inspect the Licence; and
- (c) inspect and test the Apparatus,

at any reasonable time, or when, in the opinion of the Secretary of State, an urgent situation exists, at any time, for the purpose of verifying compliance with the terms, provisions and limitations of the Licence, or investigating a radio interference problem.

Department of Trade and Industry Radiocommunications Agency
Wireless Telegraphy Act 1949 Section 1



RESTRICTION, SUSPENSION OR CLOSEDOWN

10 When, in the opinion of the Secretary of State, or of a person authorised by him in that behalf:

- (a) the Licensee or a person authorised by the Licensee under Clause 5 above is in breach of the Licence and in the circumstances such breach justifies immediate restriction or closedown; or
- (b) exceptional circumstances beyond the control of the Licensee have arisen such that any Station or Apparatus, although not operated in breach of the Licence, is causing or contributing to or aggravating undue interference with other wireless telegraphy,

the Licensee shall restrict the operation of, or closedown and cease to operate, the Station, or any Apparatus, immediately, either permanently or for a specified temporary period, in accordance with the demand of a person authorised by the Secretary of State.

PERIOD OF VALIDITY OF LICENCE

11 This Licence shall be valid from the commencement date to midnight of 17 December 1993 unless revoked earlier by the Secretary of State.

12 Any Licence which the Secretary of State has previously granted to the Licensee under the 1949 Act for any of the Stations is hereby revoked.

INTERPRETATION

13 In this Licence, unless the context otherwise requires:

- (a) the Interpretation Act 1978 shall apply to this Licence as it applies to an Act of Parliament; and
- (b) "inspect" includes examine and test.

14 The headings are for ease of reference only and shall not affect the interpretation of this Licence.

15 The Schedule is incorporated in and forms part of this Licence.

SIGNED Mrs DeFreitas

Department of Trade and Industry Radiocommunications Agency
Wireless Telegraphy Act 1949 Section 1



SCHEDULE

RA Ref: TMP/33

Call sign (if applicable):

Location of Station: Carmarthen Bay

**Purpose of Station: Transmission of environmental data from
a moored platform to a shore based logger**

Frequency: 153.3 MHz

Class of Emission: 16K0F1D

Maximum Power: -3 dBW

Antenna Characteristics: Co-Linear (omni directional)



Department of Trade and Industry Radiocommunications Agency
Wireless Telegraphy Act 1949 Section 1



NOTES

- 1 In the event of a demand to close down or restrict the operation of any Station or Apparatus under clause 9 of the Licence, the Licensee must close down or restrict the operation of the Station or Apparatus immediately. The Licensee will be given oral reasons for the demand and will have an opportunity to provide reasons why the demand should not be met. If the demand is affirmed then it will be confirmed to the Licensee in writing as soon as practicable. If the Licensee does not comply with the demand or if the breach resulting in the demand is not rectified within a reasonable period of time to the satisfaction of the Secretary of State, then revocation or variation of Licence procedures may be commenced under section 1(4) of the Act or a prosecution may be initiated (depending on the circumstances of each case).
- 2 The Licensee must apply for a variation of the Licence from the Secretary of State before making any changes which may contravene the Licence.
- 3 The Licence is not transferable.
- 4 Radiocommunications Agency is an Executive Agency of the Department of Trade and Industry acting on behalf of the Secretary of State.

Tempuse.lic



12. APPENDIX F - SHORE STATION SPECIFICATION

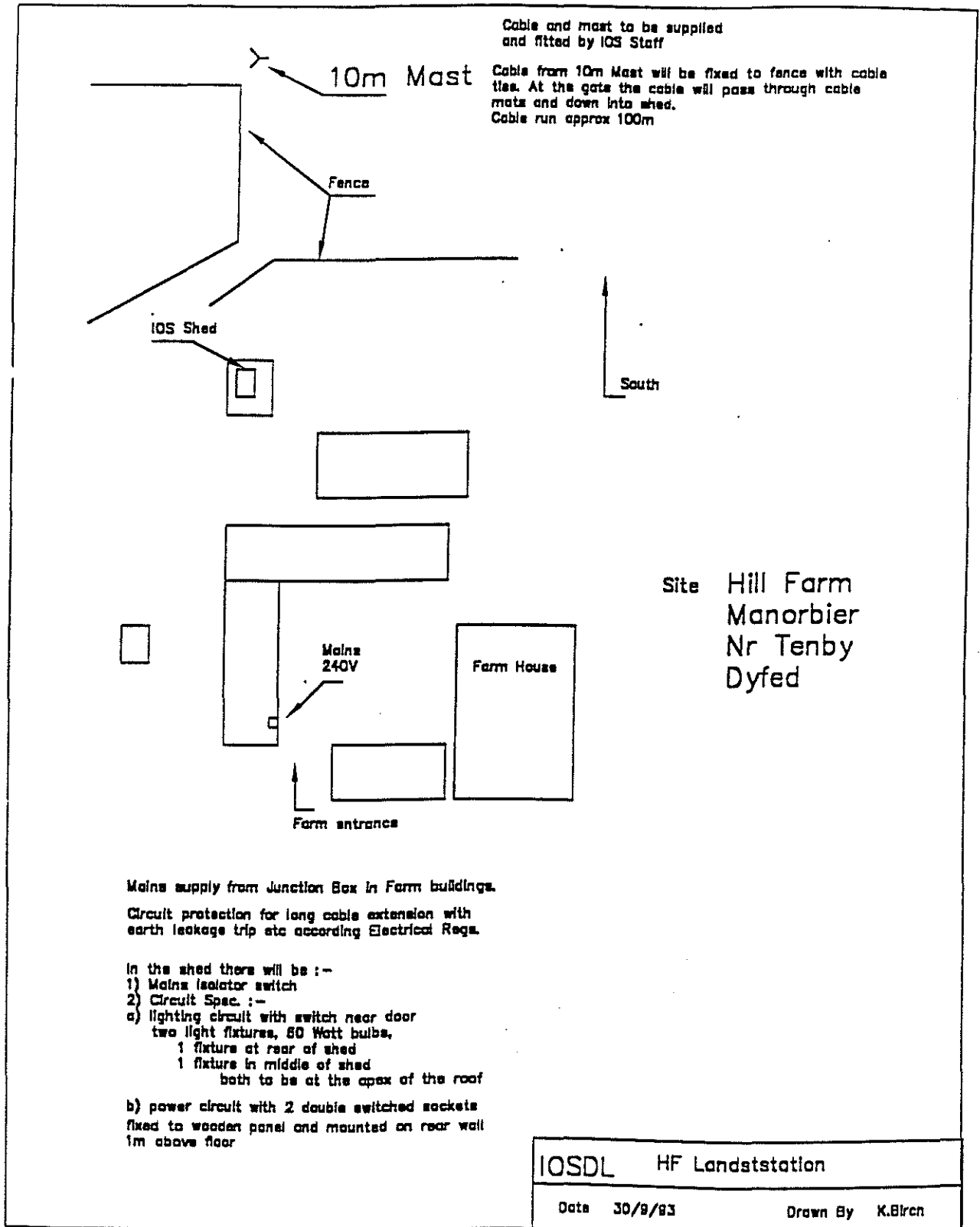

Cable supplied by IOS, and installed by contractor

Electrical fittings to be supplied by contractor

Mains supply from Junction Box in Farm buildings.

Circuit protection for long cable extension with earth leakage trip etc according Electrical Regs.

In the shed there will be :-

1) Mains isolator switch

2) Circuit Spec. :-

a) lighting circuit with switch near door

two light fixtures, 60 Watt bulbs,

1 fixture at rear of shed

1 fixture in middle of shed

both to be at the apex of the roof

b) power circuit with 2 double switched sockets

fixed to wooden panel and mounted on rear wall

1m above floor

IOSDL Landstation

Date 1/10/93

Drawn by K.Birch

13. APPENDIX G - SOFTWARE FLOW DIAGRAMS

13.1 Appendix G.1 THORREAD.C

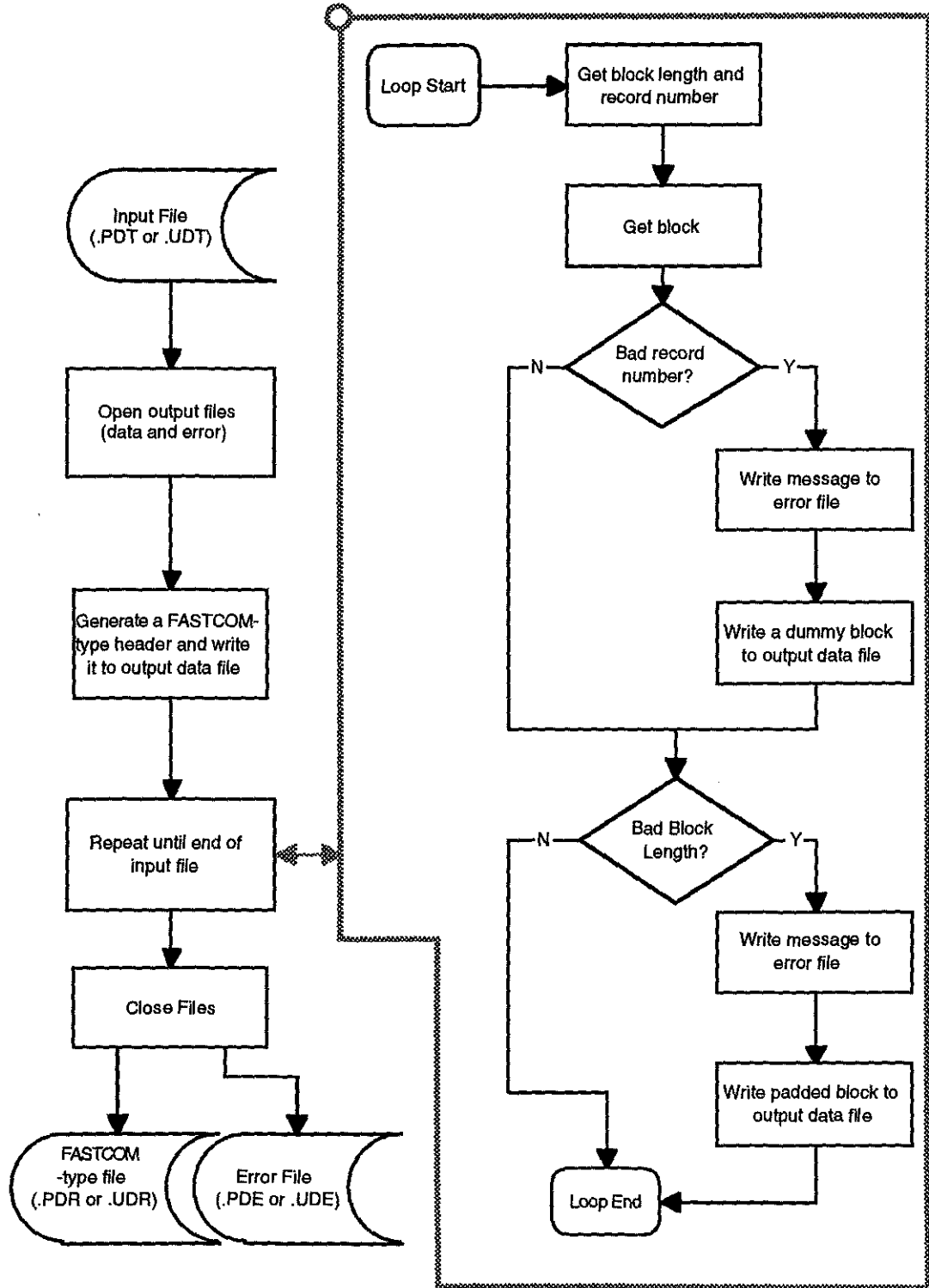

```

/*****THORREAD.C*****/
*
* Converts files produced by the THORCOM telemetry logging system
* to the standard file format produced by FASTCOM
* (as produced by the ship system)
*
* Deals with errors as follows:
*   if a data packet is missing, inserts a packet of all zero values
*   with length 210 bytes
*
*   if a data packet is short (non multiple of 10 bytes), adds zero
*   values to make it up to length 210 bytes
*
* NB packets are normally of length 200, 210 or 220 bytes,
*   210 is used as best guess for correct number for prompted data
*   200 is used as best guess for unprompted data
*
* NB first packet is discarded as it normally contains dud data
*   resulting from change from prompted to unprompted during fill
*   of the anemometer output buffer
*
* Writes description of each error to an individually named error file (.PDE or .UDE)
*
* Call with path/filename added, e.g. THORREAD C:\LOGDATA\11021015.PDT
* (or use suitably modified batch file TXPDR.BAT or TXUDR.BAT)
* This results in a FASTCOM-type file named   C:\DATA\11021015.PDR
* and an ASCII error file named              C:\DATA\11021015.PDE
*
* CHC
* 25th October 1993
*
*****/

```

13.1. Appendix G.2 THORSTAT.C

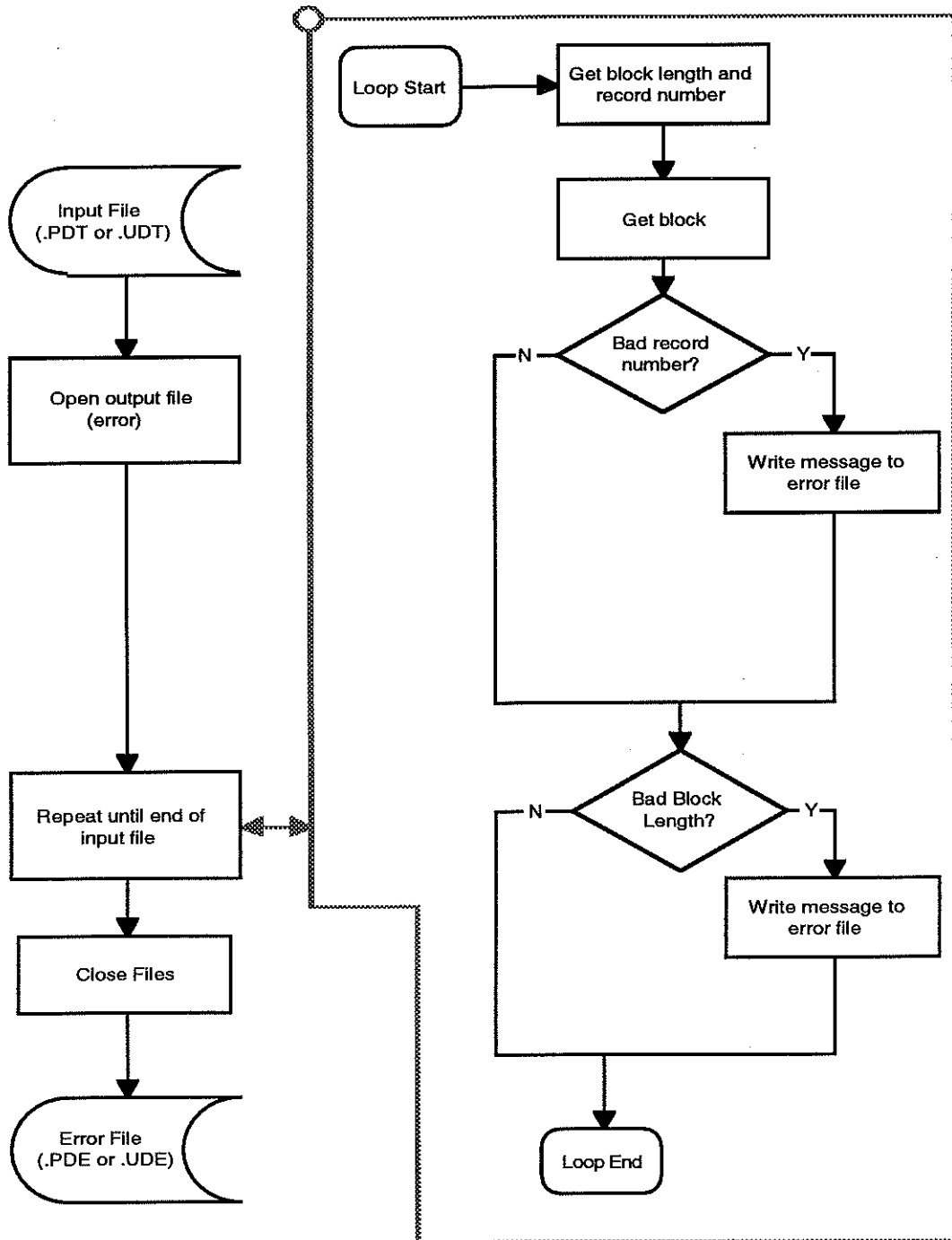

/******THORSTAT.C*****
*

* Reads files produced by the THORCOM system and produces error files
*

* Writes description of each error to an individually named error file (.PDE or .UDE)
*

* Call with path/filename added, e.g. THORSTAT C:\LOGDATA\11021015.PDT
* (or use a modified form of TXPDR.BAT and TXUDR.BAT)

* This results in an ASCII error file named
C:\DATA\11021015.PDE

*
* CHC

* 19th January 1994
*

*****/
*/

13.2. Appendix G.3 THORSUMM.C

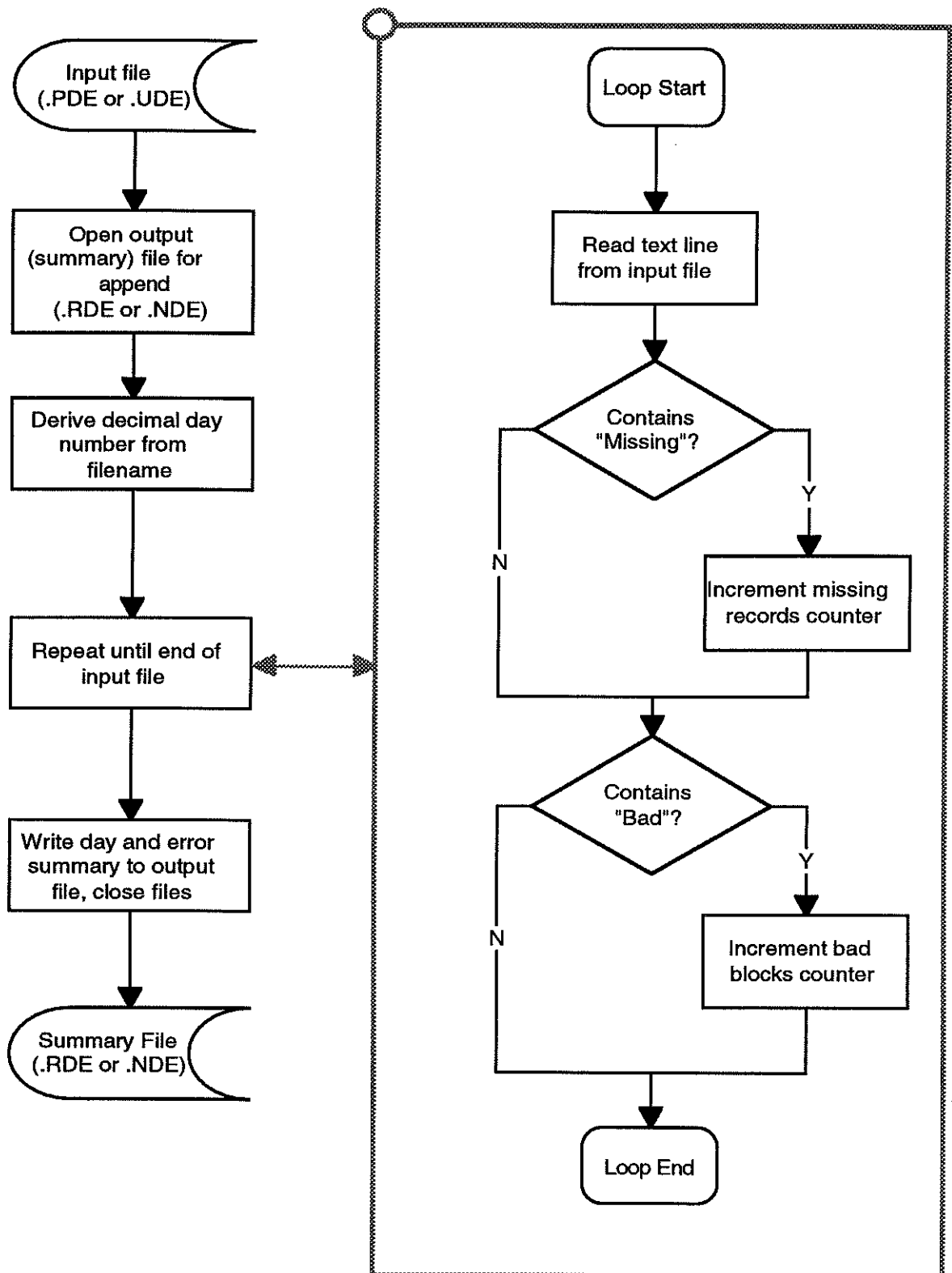

```

/*****THORSUMM.C*****/
*
* Reads .PDE and .UDE error files produced by the THORSTAT program and appends to
* a .RDE or .NDE summary file
*
* Call with path/filename added, e.g. THORSUMM C:\DATA\1102?????.PDE
* (or use a suitably modified form of SUMPDE.BAT or SUMUDE.BAT)
* This results in data statistics being appended to an ASCII error file named
      7.3.1.\DATA\SUMMARY.RDE
*
* CHC
* 19th January 1994
*

```

13.3. Appendix G.4 REPLAY2.C

```

/*****
Program REPLAY2.C
Version 1.1 28th October 1993
Author CHC
Compile using command line:
      qcl /AM /Zr /FPi87 replay2.c /F 9000 mlibc7.lib

```

Sonic processing program: use to replaying an existing Mode 1 raw data file, with 1 analogue channel for compass as used in sonic buoy, with save of spectral data .PRN and parameter .MWS files to floppy and hard disks

Requires fast 286 or 386 processor with coprocessor
Install in c:\sonic directory together with SETUP.SON (configuration file)

Throws out bad data

Call using command line REPLAY2 n path/name
where n is number of FFT sections expected (12 for a .PDR file, 6 for a .UDR file)
and path/name is the path and name of the .PDR or .UDR file, e.g. C:\DATA\11021015.PDR

Alternatively, use batch file REPPDR.BAT or REPUDR.BAT
Spectrum will be written to hard and floppy disk .PRN and .MWS files
e.g.
C:\DATA\11021015.PRN, C:\DATA\11021015.MWS, A:\11021015.PRN, A:\11021015.MWS

```

*****

```

14. APPENDIX H - USEFUL ADDRESSES

Thorcom Ltd
Unit 4
96B Blackpole Trading Estate West
Worcester
WR3 8TJ
Telephone Number 0905 756700

Licencing Agency

Further information :-

Tempport Use Licence Section
Radiocommunications Agency
Room 712
Waterloo Bridge House
Waterloo Road
London
SE1 8UA

Telephone Number 071 215 2407

For Application Form :-

The Library
Radiocommunications Agency
Room 605
Waterloo Bridge House
Waterloo Road
London
SE1 8UA

Telephone Number 071 215 2352

or 071 215 2140
or 071 215 2072 (24hrs answering machine)